

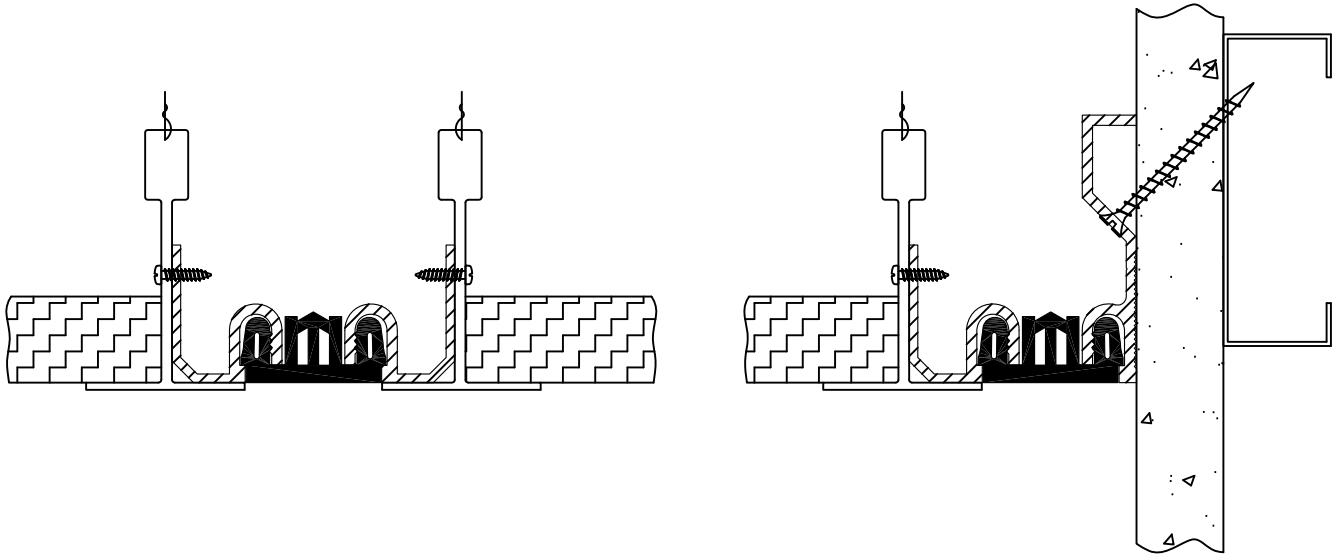

Erie Metal Specialties, Inc.  
13311 Main Road  
Akron, NY 14001

Phone: 716-542-3991  
Website: [www.eriemetal.com](http://www.eriemetal.com)  
E-Mail: [sales@eriemetal.com](mailto:sales@eriemetal.com)



## Seal Wall - Standard Series Model(s) "ELCA-100/200/300" & "ELCA-100W/200W/300W" Vertical Expansion Control Systems

The following installation procedure is very important and must be fully understood prior to beginning any work. To ensure proper installation and performance of expansion joint system the following actions must be completed by the installing contractor. Failure to do so will affect product warranty.

- 1) Carefully read and understand installation procedure. Contact Technical Service Department for product assistance.
- 2) Inspect all shipments and materials for missing or damaged components and hardware. Contact Customer Service with order number and invoice for prompt assistance.
- 3) Inspect substrate or adjacent construction for acceptance before beginning work. Report unacceptable construction to the project manager for scheduled repair work.

# Standard Components

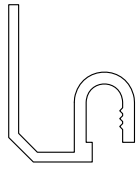

Ceiling Extrusion  
Part Number-27426

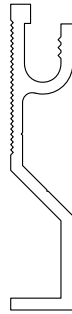

Corner Wall Extrusion  
Part Number-27427



\*\*SI 750 Adhesive  
Part Number - 27514

\*\*Optional components for splice procedures. Place order for required quantities.

Components shown below vary in size depending on  
model of system

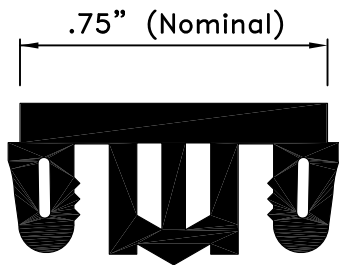

ELCA-100  
ELCA-100W

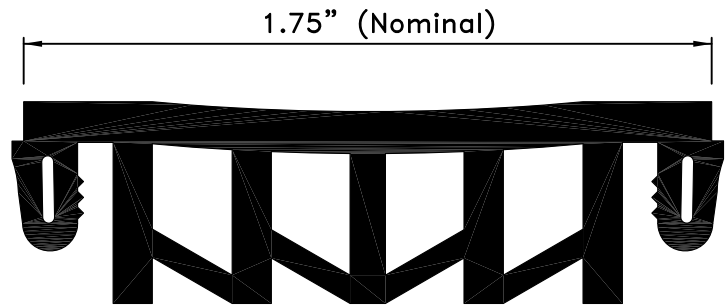

ELCA-200  
ELCA-200W

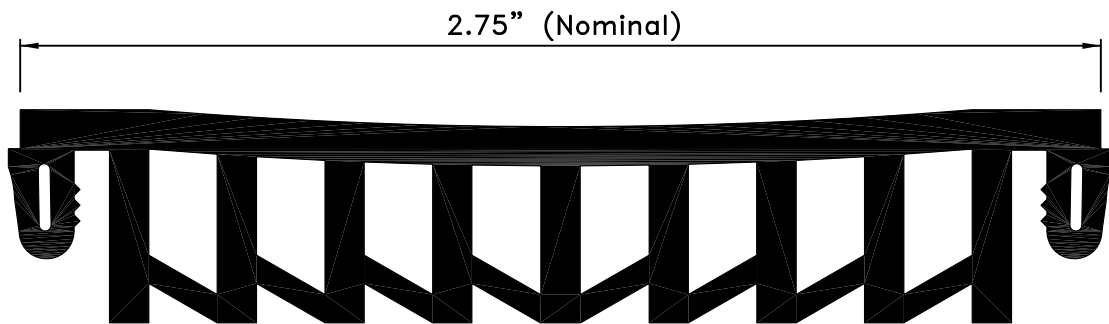

ELCA-300  
ELCA-300W

Seal Part Number				
Model	Black Seal	White Seal	Grey Seal	Beige Seal
ELCA-100	28001	28002	28003	28004
ELCA-200	28005	28006	28007	28008
ELCA-300	28031	28032	28033	28034

# Installation Procedure

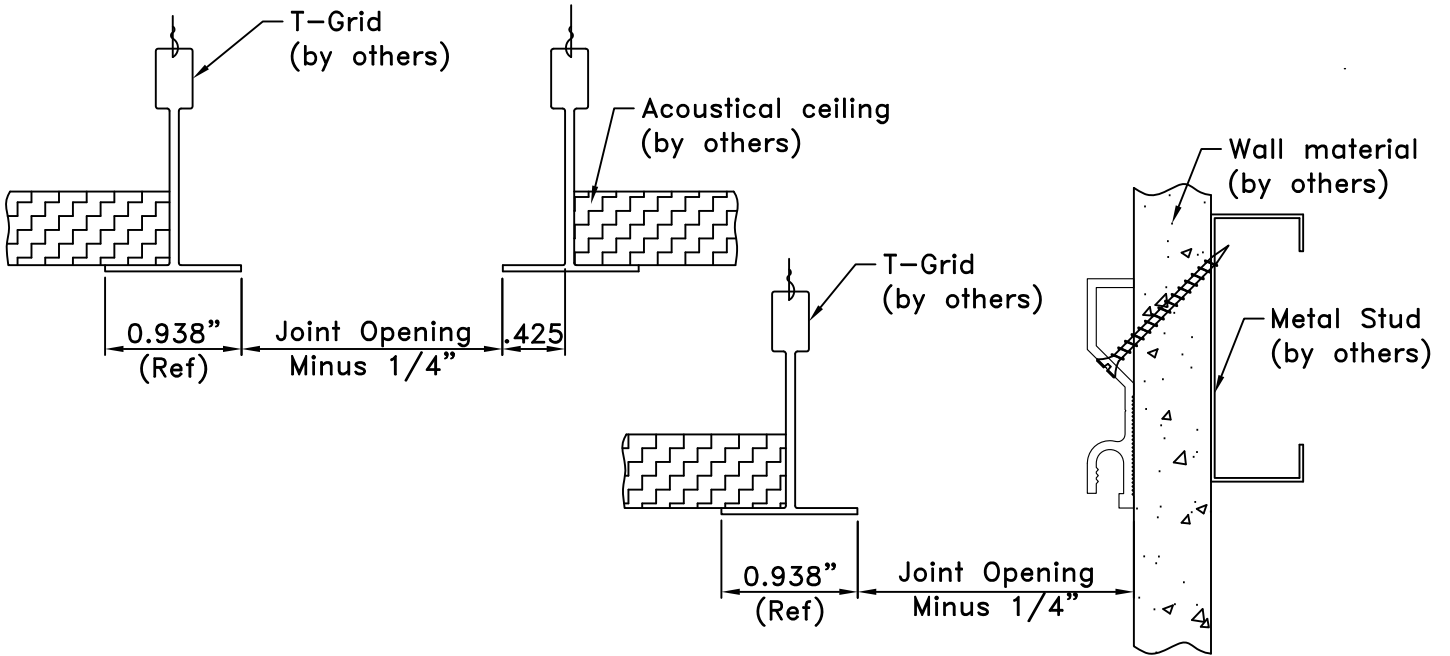

1

Prior to beginning work, installer shall inspect for proper ceiling construction. Verify joint opening to match expansion control system requirements.

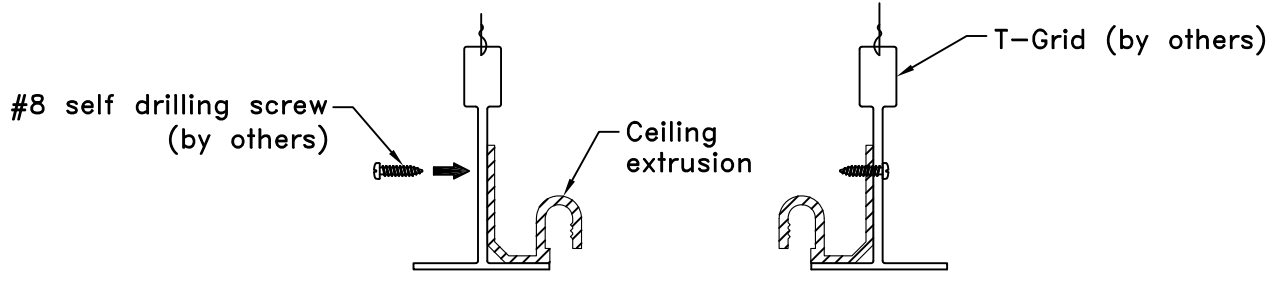

2

Prior to fastening the ceiling extrusion to the "T" grid, remove ceiling tiles on both sides of the joint location. Once ceiling tiles have been removed, the contractor can fasten the aluminum extrusion to the "T" grid using at least #8 self drilling screws (by others) space at 24" O.C.

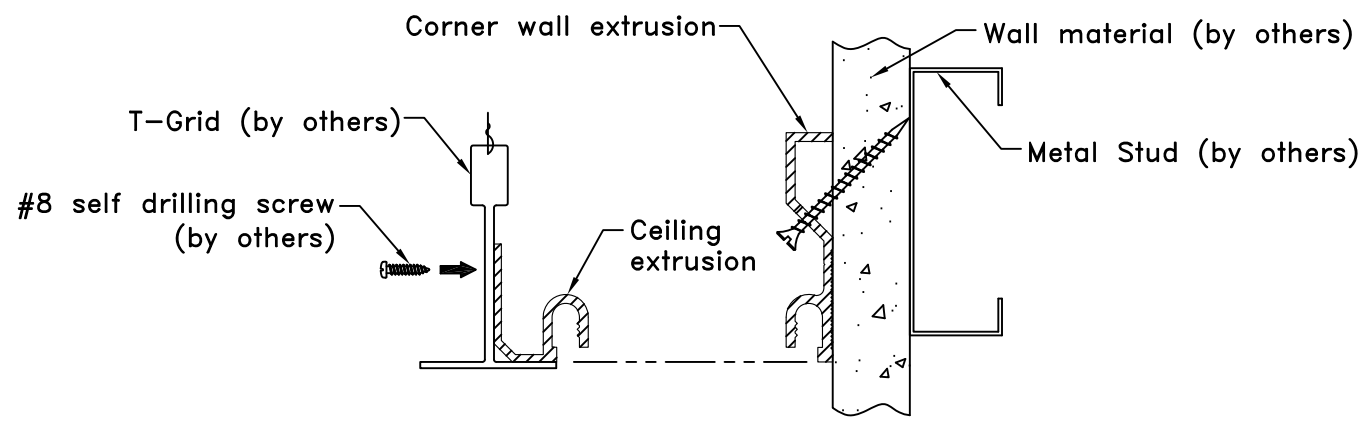

2A

Place aluminum corner wall extrusion on edge of opening as shown. Drill through extrusion, drywall and into stud. Fasten with drywall screws (by others) spaced at 24" O.C. max, starting 6" from ends. Prior to fastening the ceiling extrusion to the "T" grid, remove ceiling tiles on both sides of the joint location. Once ceiling tiles have been removed, the contractor can fasten the aluminum extrusion to the "T" grid using at least #8 self drilling screws (by others) space at 24" O.C.

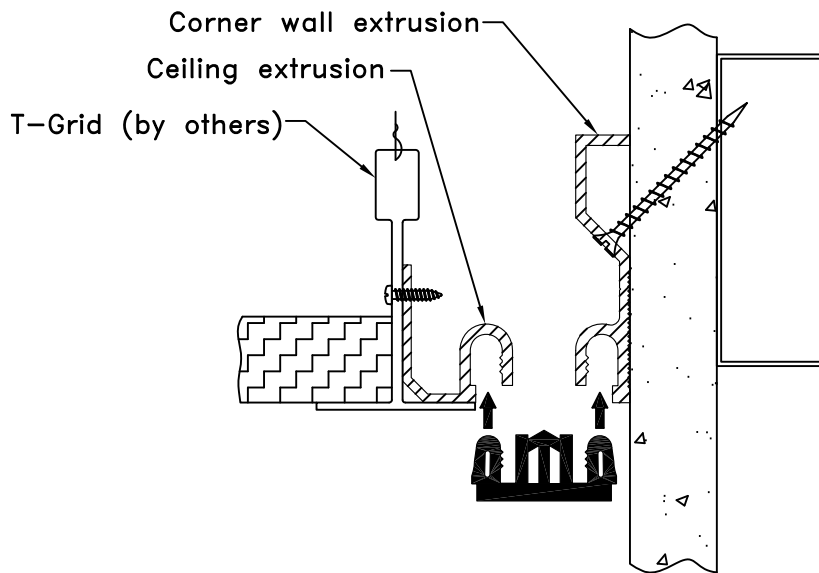
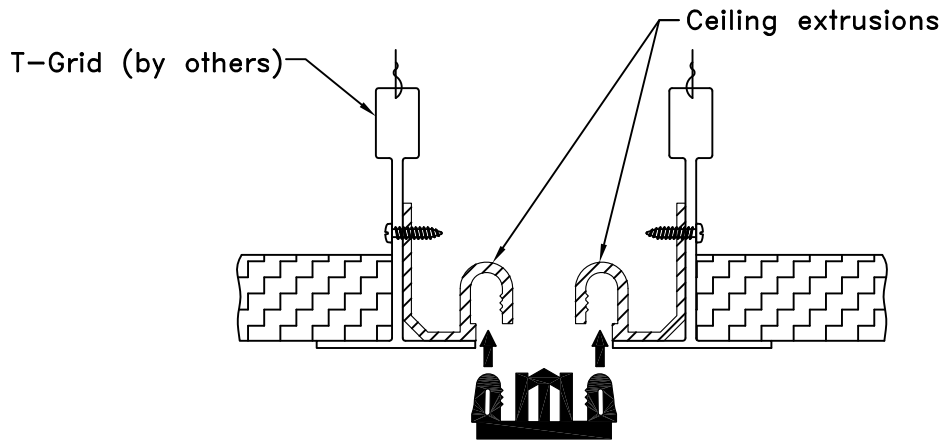

3

Squeeze or slide elastomeric seal into the cavities of the aluminum extrusion.

## Suggested Field Splice Procedure

1. Cut ends of seal with a sharp knife and miter box to the desired angle. Insure that cuts are clean and straight.
2. Clean ends of seal with a solvent.
3. Apply SI 750 Adhesive to one of the two seal ends to be bonded.
4. Apply pressure bringing the two surfaces into tight contact immediately after adhesive is applied. Hold in place for one to two minutes for initial bond.
5. Re-Check quality of all splices/miters and apply adhesive as required.
7. It is usually recommended to allow 15 minutes prior to installing seal. To achieve proper working strength care shall be exercised as a result that it takes 24 hours for adhesive to fully cure.

