

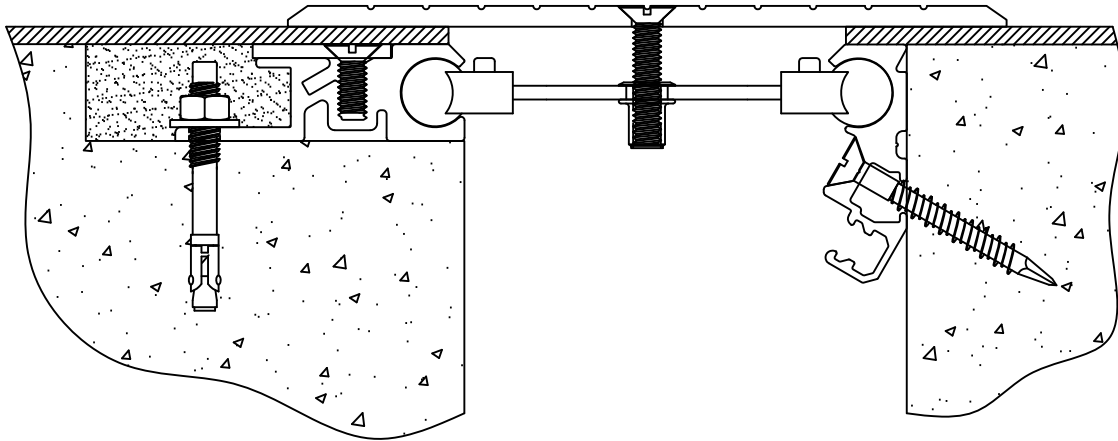

Erie Metal Specialties, Inc.  
13311 Main Road  
Akron, NY 14001

Phone: 716-542-3991  
Website: [www.eriemetal.com](http://www.eriemetal.com)  
E-Mail: [sales@eriemetal.com](mailto:sales@eriemetal.com)



## Seismic Floor System Model(s) ESFB-400/600/800/1000/1200/1800 Horizontal Expansion Control Systems

The following installation procedure is very important and must be fully understood prior to beginning any work. To ensure proper installation and performance of expansion joint system the following actions must be completed by the installing contractor. Failure to do so will affect product warranty.

- 1) Carefully read and understand installation procedure. Contact Technical Service Department for product assistance.
- 2) Inspect all shipments and materials for missing or damaged components and hardware. Contact Customer Service with order number and invoice for prompt assistance.
- 3) Inspect substrate or adjacent construction for acceptance before beginning work. Report unacceptable construction to the project manager for scheduled repair work.

# Standard Components

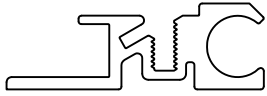

Aluminum base assembly  
PN: 15804

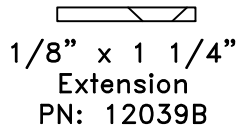

1/8" x 1 1/4"  
Extension  
PN: 12039B

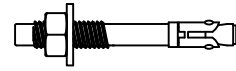

1/4" x 2-1/4"  
Concrete anchor with nut  
and washer  
PN: 6581



1/4" x 2-1/4"  
Tapcon anchor  
PN: 6526



Aluminum Edge Assembly  
PN: 15398



1/4" X 1 1/4" Lg Screw  
PN: 5621



1/4" X 5/8" Lg Screw  
PN: 5620

Components shown below vary in size depending on model of system

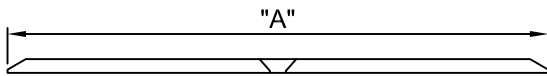

Aluminum Cover Plate

Model	"A"	Part Number
ESFB-400	6 1/2"	12032B
ESFB-600	9 1/2"	12033B
ESFB-800	12 1/2"	12025
ESFB-1000	15 1/2"	12026
ESFB-1200	18 1/2"	12027
ESFB-1800	27 1/2"	12028

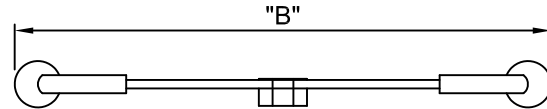

Self-centering bar

Model	"B"	Part Number
ESFB-400	7 3/8"	15642
ESFB-600	12 3/8"	15643
ESFB-800	18 3/8"	15630
ESFB-1000	18 3/8"	15630
ESFB-1200	22 3/8"	15631
ESFB-1800	32 3/8"	15644

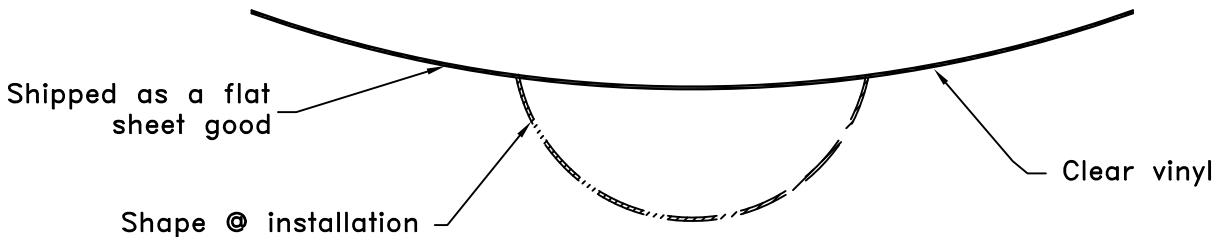

Optional Moisture Barrier

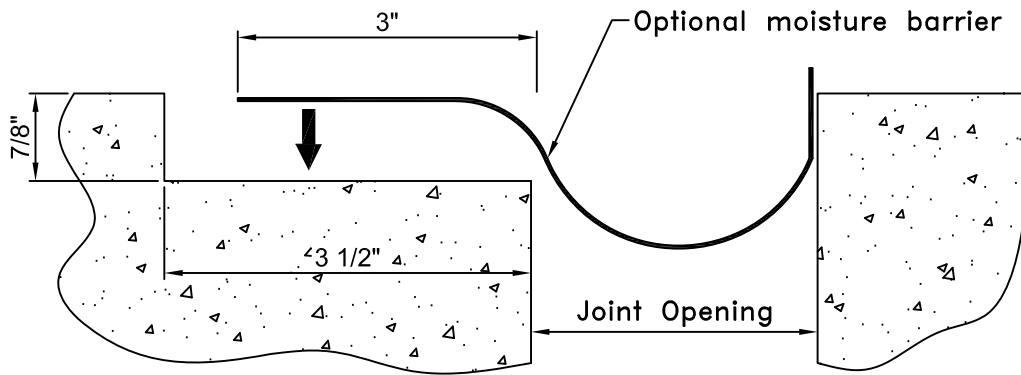

1

(Optional)  
Position moisture barrier in to blockout. Maintain proper overlap and temporarily affix with duct tape (if required).

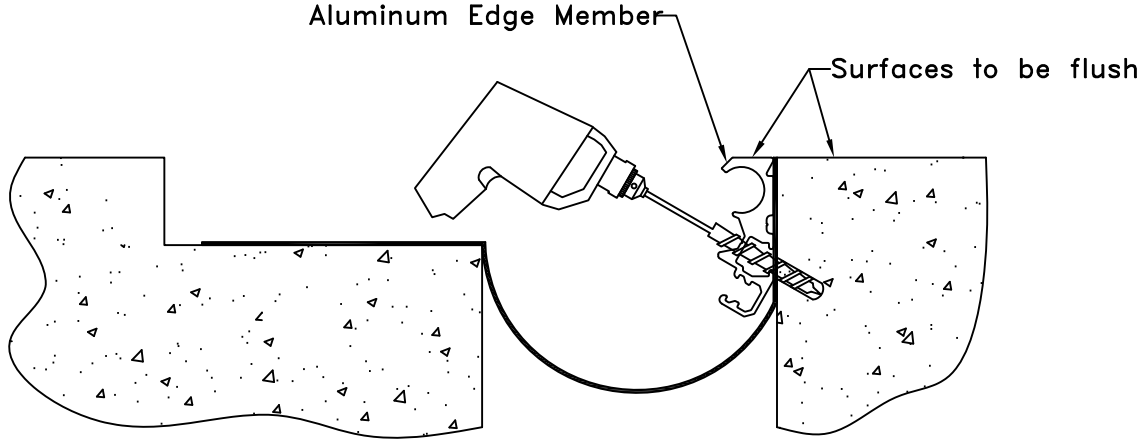

2

Position Aluminum Edge Assembly so that the top is Flush with the top of the Concrete Surface. Using base member as a template and with its position fixed, drill holes for 1/4" x 2 1/4" Tapcon anchor (PN:6526) spaced at 24" O.C. to the proper depth. Clean out holes and install anchor.

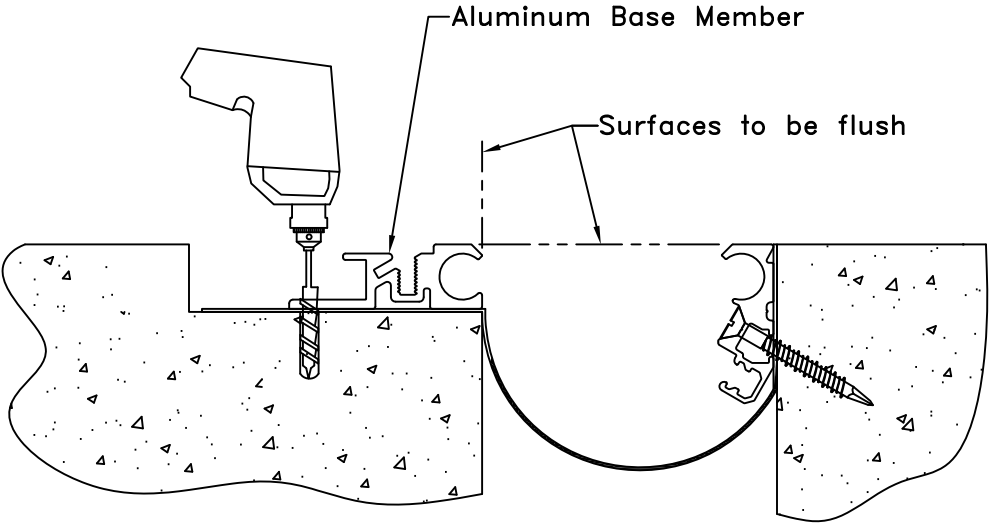

3

Position base member on block out so cavity of base member is flush with edge of opening. Using base member as a template and with its position fixed, drill holes for 1/4" x 2 1/4" Concrete anchor (PN:6581) spaced at 24" O.C. to proper depth. Clean out holes and install anchor. After base members have been installed, the contractor can cut the excess (Optional) Moisture Barrier flush with the face of the base member.

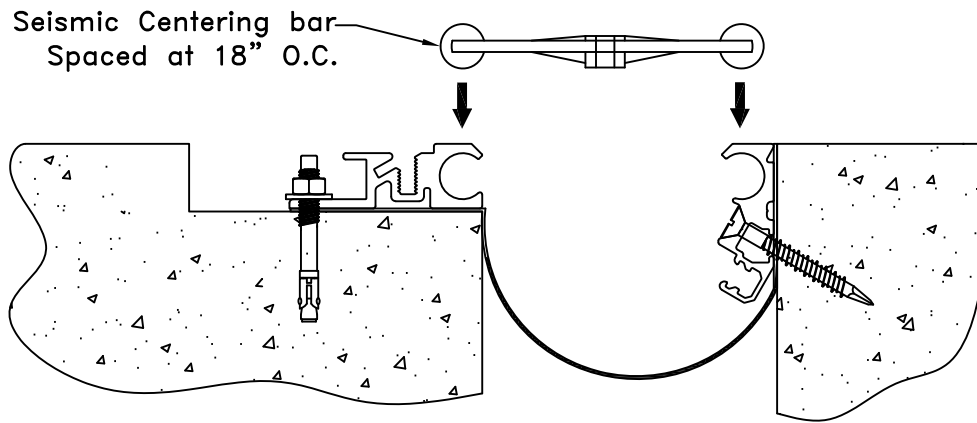

4

As work progresses with placement of base members, install self-centering bars by sliding the spherical ends of the bars into and through the circular cavities of the base members. Set at an approximate spacing of 18" O.C. Ensure that the "top" indicator is facing up and that all bars are in same orientation.

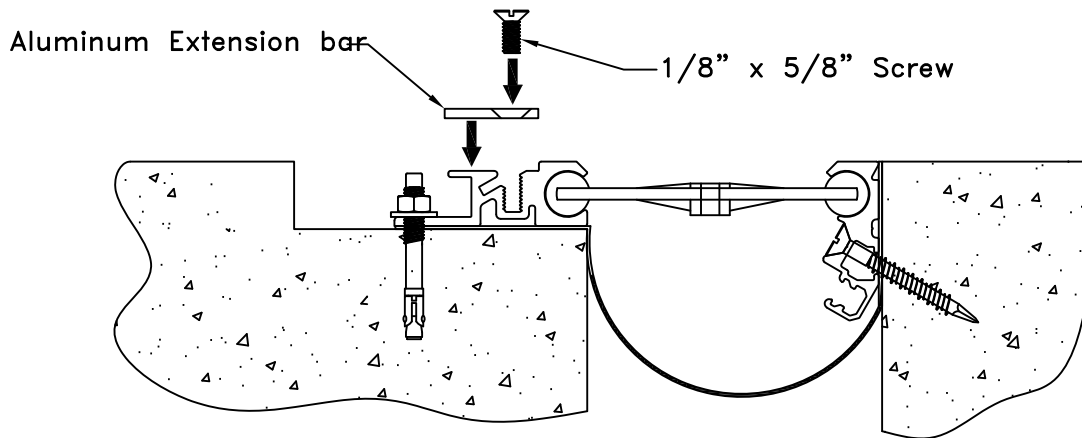

5

Place Aluminum Extension Bar into the recess in the Base Member and fasten with the 1/4" x 5/8" Long Screws spaced at 18" O.C.

Blockout Infill material  
(By Others)

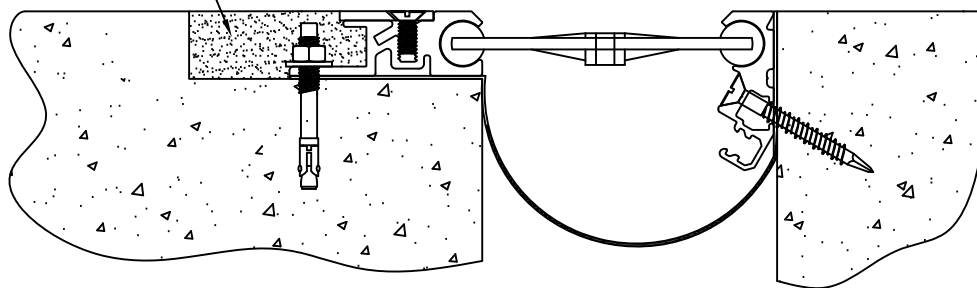

6

Fill block out with high quality non-shrink cementitious filler material. Protect surfaces during placement of filler material.

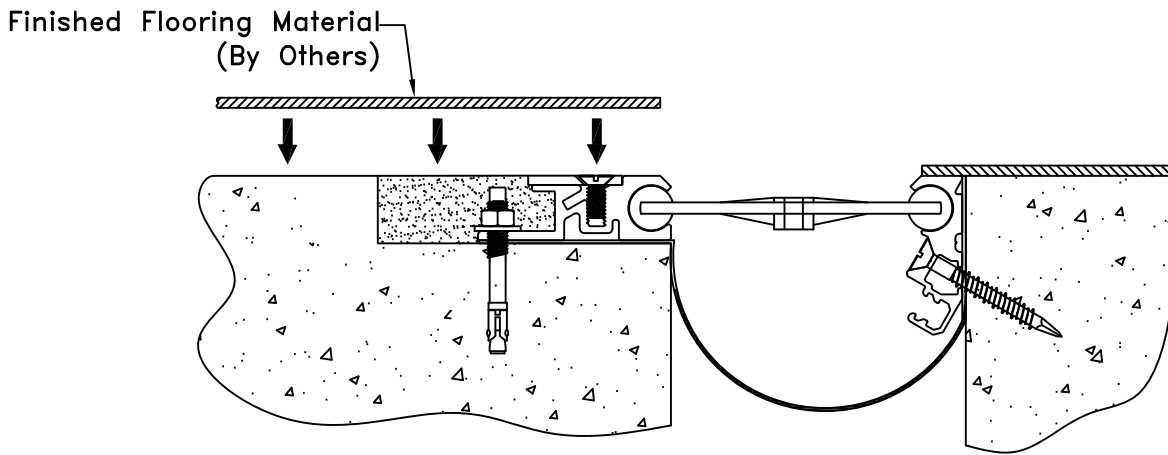

- 7** Install Finished Flooring material. Ensure flush installation with top of expansion joint system.  
**Caution** – Contact flooring manufacturer to discuss application and procedure for proper installation.

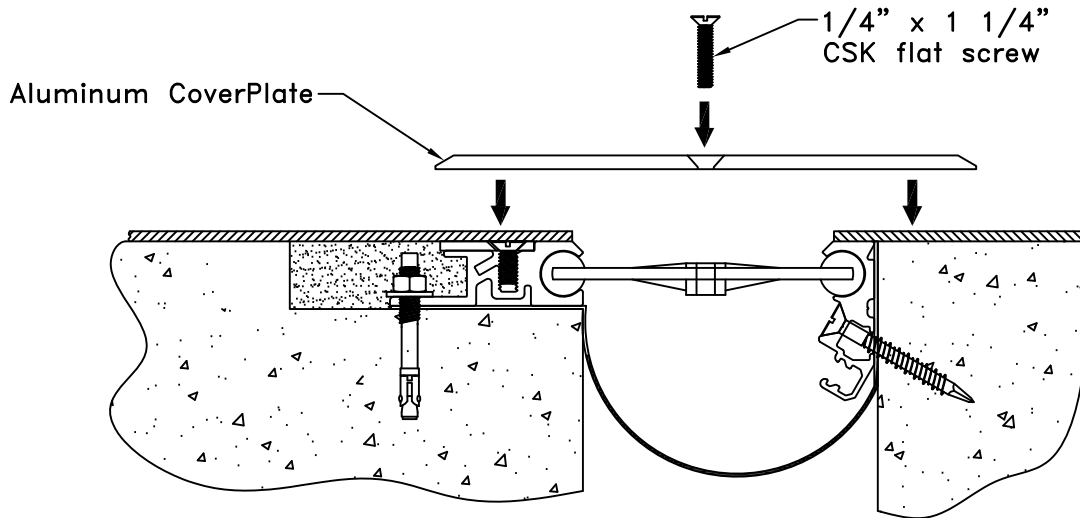

- 8** Position the center slide plate over expansion opening, align pre-drilled holes in slide plate with threaded insert in self-centering bars. Fasten with 1/4" x 1 1/4" CSK flat screw. Tighten to create measurable tension in the bar.