

ELCH-100 DETAIL
WALL TO WALL CONDITION

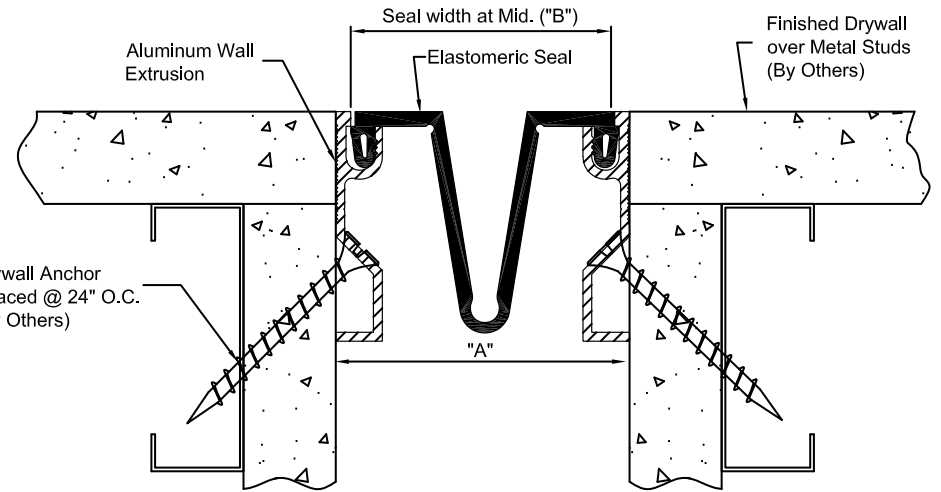

ELCH-200 & ELCH-300 DETAIL
WALL TO WALL CONDITION

() - Denotes Millimeters

Dimension Chart					
MODEL	"A" @ Min.	"A" @ Mid.	"A" @ Max.	Total Mv't	"B"
ELCH-100	.50"(13)	1.00"(25)	1.50"(38)	1.00"(25)	1.00"(25)
ELCH-200	1.00"(25)	2.00"(51)	3.00"(76)	2.00"(51)	2.00"(51)
ELCH-300	1.50"(38)	3.00"(76)	4.50"(114)	3.00"(76)	3.00"(76)

NO.	Description	Date	By
<p>The information contained herein is the proprietary property of ERIE METAL SPECIALTIES, INC. No portion of it may be reproduced by any means or used in any form except for the purpose for which it was intended. All rights of design and invention are hereby reserved.</p>			



13311 Main Road • Akron • New York • 14001
 Phone: (716) 542-3991 • Fax: (716) 542-3996 • E-mail: sales@eriemetal.com

PROJECT:

TITLE:

Detailed by: BAF	Date: 10/21/17
Checked By: SLP	Date: 10/21/17
Scale: NTS	EMS Job #:
Sheet No.: 1 of 1	Drawing No.:

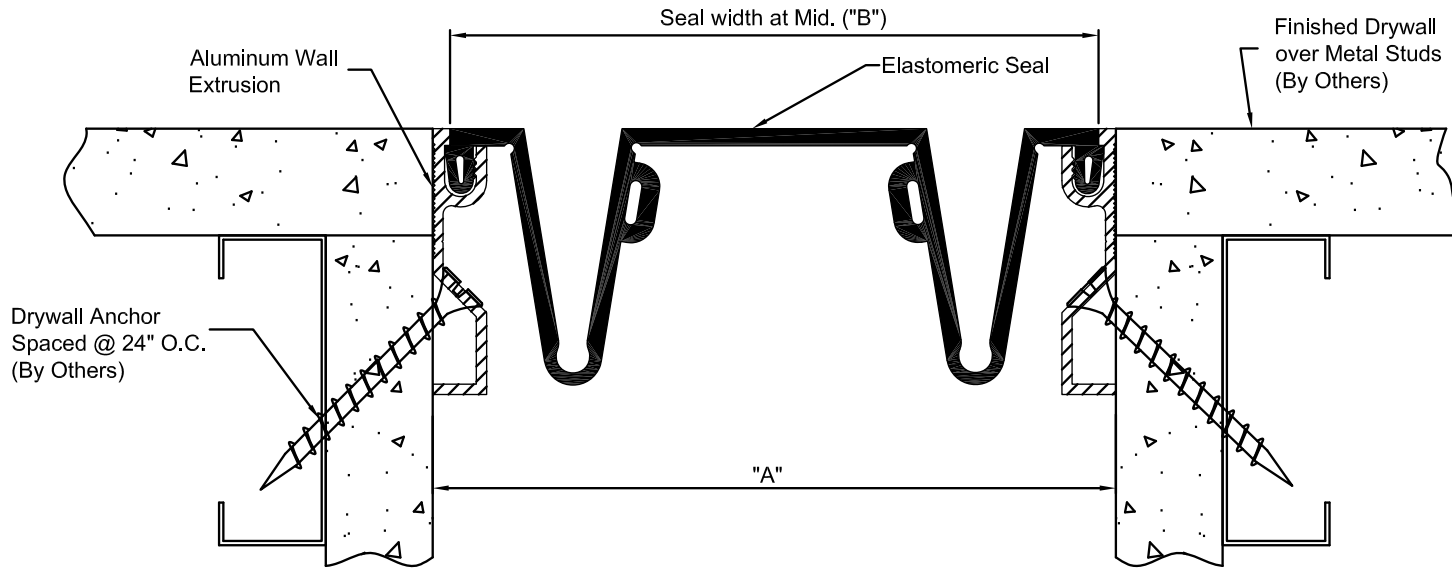

ELCH-400, ELCH-500, ELCH-600 DETAIL
WALL TO WALL CONDITION

() - Denotes Millimeters

Dimension Chart					
MODEL	"A" @ Min.	"A" @ Mid.	"A" @ Max.	Total Mv't	"B"
ELCH-400	2.00"(51)	4.00"(102)	6.00"(152)	4.00"(102)	4.00"(102)
ELCH-500	2.50"(64)	5.00"(127)	7.50"(191)	5.00"(127)	5.00"(127)
ELCH-600	3.00"(76)	6.00"(152)	9.00"(229)	6.00"(152)	6.00"(152)

NO.	Description	Date	By
<p>The information contained herein is the proprietary property of ERIE METAL SPECIALTIES, INC. No portion of it may be reproduced by any means or used in any form except for the purpose for which it was intended. All rights of design and invention are hereby reserved.</p>			



13311 Main Road • Akron • New York • 14001
Phone: (716) 542-3991 • Fax: (716) 542-3996 • E-mail: sales@eriemetal.com

PROJECT:

TITLE:

Detailed by: BAF	Date: 10/21/17
Checked By: SLP	Date: 10/21/17
Scale: NTS	EMS Job #:
Sheet No.: 1 of 1	Drawing No.: