



SUBSTITUTION REQUEST

(After the Bidding/Negotiating Phase)

Project: _____ Substitution Request Number: _____

 From: _____
 To: _____ Date: _____

 A/E Project Number: _____
 Re: _____ Contract For: _____

Specification Title: _____ Description: _____
 Section: _____ Page: _____ Article/Paragraph: _____

Proposed Substitution: _____
 Manufacturer: _____ Phone: _____
 Address: _____
 Trade Name: _____ Model No.: _____
 Installer: _____ Phone: _____
 Address: _____

History: New product 1-4 years old 5-10 years old More than 10 years old

Differences between proposed substitution and specified product: _____

Point-by-point comparative data attached — REQUIRED BY A/E

Reason for not providing specified item: _____

Similar Installation:

Project: _____ Architect: _____
 Address: _____ Owner: _____
 _____ Date Installed: _____

Proposed substitution affects other parts of Work: No Yes; explain _____

Savings to Owner for accepting substitution: _____ (\$ _____).

Proposed substitution changes Contract Time: No Yes [Add] [Deduct] _____ days.

Supporting Data Attached: Drawings Product Data Samples Tests Reports _____

SUBSTITUTION REQUEST

(After the Bidding/Negotiating Phase — Continued)

The Undersigned certifies:

- Proposed substitution has been fully investigated and determined to be equal or superior in all respects to specified product.
 - Same warranty will be furnished for proposed substitution as for specified product.
 - Same maintenance service and source of replacement parts, as applicable, is available.
 - Proposed substitution will have no adverse effect on other trades and will not affect or delay progress schedule.
 - Cost data as stated above is complete. Claims for additional costs related to accepted substitution which may subsequently become apparent are to be waived.
 - Proposed substitution does not affect dimensions and functional clearances.
 - Payment will be made for changes to building design, including A/E design, detailing, and construction costs caused by the substitution.
 - Coordination, installation, and changes in the Work as necessary for accepted substitution will be complete in all respects.
-

Submitted by: _____

Signed by: _____

Firm: _____

Address: _____

Telephone: _____

Attachments:

A/E's REVIEW AND ACTION

- Substitution approved - Make submittals in accordance with Specification Section 01 25 00 Substitution Procedures.
- Substitution approved as noted - Make submittals in accordance with Specification Section 01 25 00 Substitution Procedures.
- Substitution rejected - Use specified materials.
- Substitution Request received too late - Use specified materials.

Signed by: _____ Date: _____

Additional Comments: Contractor Subcontractor Supplier Manufacturer A/E
 Other:

ESFB Series Renovation Application

The Renovation Seismic Expansion Joint System is designed for renovation building projects where an expansion joint is needed to tie new construction to existing construction. The system is bolted into the existing construction and a block out with back fill is necessary for the new construction.

FEATURES

SEISMIC TECHNOLOGY The cover plate stays centered over openings before, during and after a seismic event with the use of the seismic centering bar.

ANTI-SLIP SURFACE Designed with serrations to create an anti-slip surface.

ADA COMPLIANT Heavy-duty loading requirements are met while maintaining a smooth ADA compliant transition.

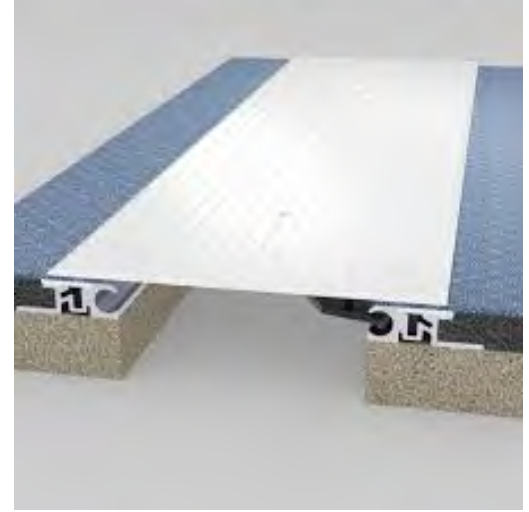

DETAILS

MATERIAL 6063-T6 Aluminum

FINISH Mill

MOVEMENT

- Thermal: Horizontal and Vertical
- Seismic: Lateral Shear

MOUNTING Block Out and Surface Mount

JOINT SIZE 4 inches to 18 inches

LENGTH 10 Linear Feet

APPLICATION Interior

LOAD Pedestrian and Light Cart

INSTALLATION Floor

OPTIONS Moisture Barrier, Fire Barrier

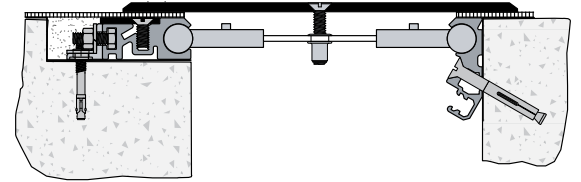

Floor-to-Floor

MODELS

MODEL	JOINT SIZE AT MEAN T°F	SYSTEM WIDTH	TOTAL MOVEMENT
ESFB-400	4" (102mm)	6.5" (165mm)	5" (127mm)
ESFB-600	6" (152mm)	9.5" (241mm)	8" (203mm)
ESFB-800	8" (203mm)	12.5" (318mm)	11" (279mm)

MODEL	JOINT SIZE AT MEAN T°F	SYSTEM WIDTH	TOTAL MOVEMENT
ESFB-1000	10" (254mm)	15.5" (394mm)	14" (356mm)
ESFB-1200	12" (305mm)	18.5" (470mm)	17" (432mm)
ESFB-1800	18" (457mm)	27.5" (699mm)	26" (660mm)



Erie Metal Specialties, Inc.
13311 Main Road
Akron, NY 14001

Phone: 716-542-3991
Website: www.eriemetal.com
E-Mail: sales@eriemetal.com



Erie Metal Specialties, Inc.
13311 Main Road
Akron, NY 14001

Phone: 716-542-3991
Website: www.eriemetal.com
E-Mail: sales@eriemetal.com

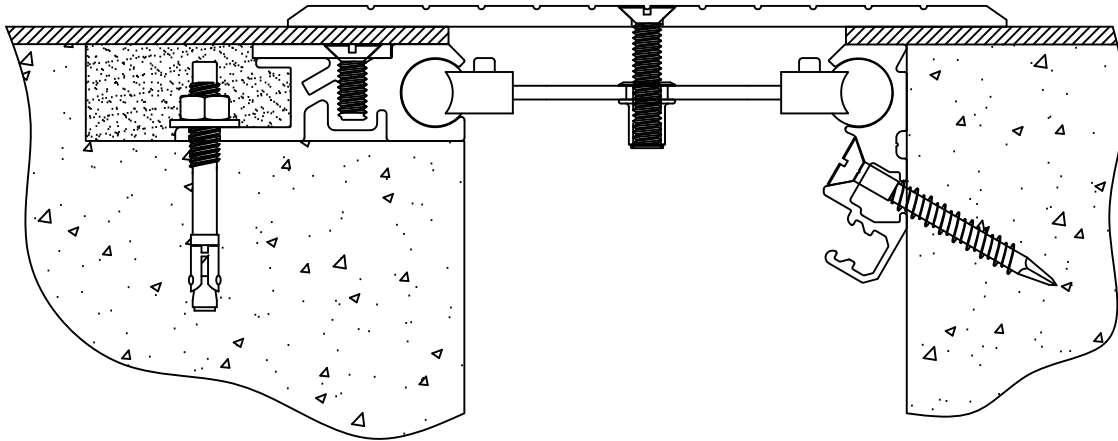

Seismic Floor System Model(s) ESFB-400/600/800/1000/1200/1800 Horizontal Expansion Control Systems

The following installation procedure is very important and must be fully understood prior to beginning any work. To ensure proper installation and performance of expansion joint system the following actions must be completed by the installing contractor. Failure to do so will affect product warranty.

- 1) Carefully read and understand installation procedure. Contact Technical Service Department for product assistance.
- 2) Inspect all shipments and materials for missing or damaged components and hardware. Contact Customer Service with order number and invoice for prompt assistance.
- 3) Inspect substrate or adjacent construction for acceptance before beginning work. Report unacceptable construction to the project manager for scheduled repair work.

Standard Components

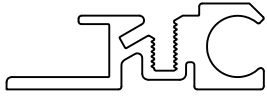

Aluminum base assembly
PN: 15804

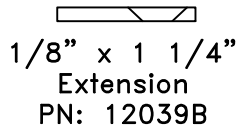

1/8" x 1 1/4"
Extension
PN: 12039B

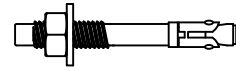

1/4" x 2-1/4"
Concrete anchor with nut
and washer
PN: 6581



1/4" x 2-1/4"
Tapcon anchor
PN: 6526



Aluminum Edge Assembly
PN: 15398



1/4" X 1 1/4" Lg Screw
PN: 5621



1/4" X 5/8" Lg Screw
PN: 5620

Components shown below vary in size depending on model of system

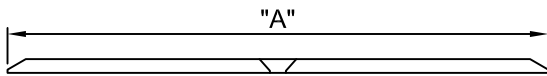

Aluminum Cover Plate

Model	"A"	Part Number
ESFB-400	6 1/2"	12032B
ESFB-600	9 1/2"	12033B
ESFB-800	12 1/2"	12025
ESFB-1000	15 1/2"	12026
ESFB-1200	18 1/2"	12027
ESFB-1800	27 1/2"	12028

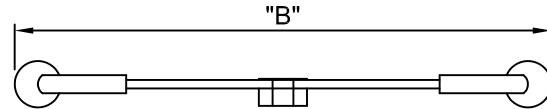

Self-centering bar

Model	"B"	Part Number
ESFB-400	7 3/8"	15642
ESFB-600	12 3/8"	15643
ESFB-800	18 3/8"	15630
ESFB-1000	18 3/8"	15630
ESFB-1200	22 3/8"	15631
ESFB-1800	32 3/8"	15644

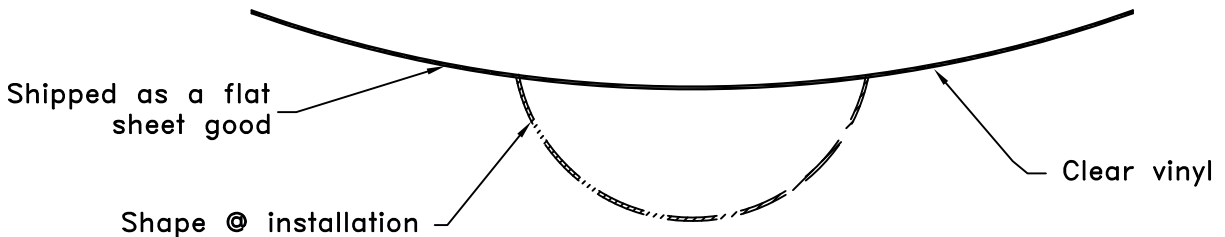

Optional Moisture Barrier

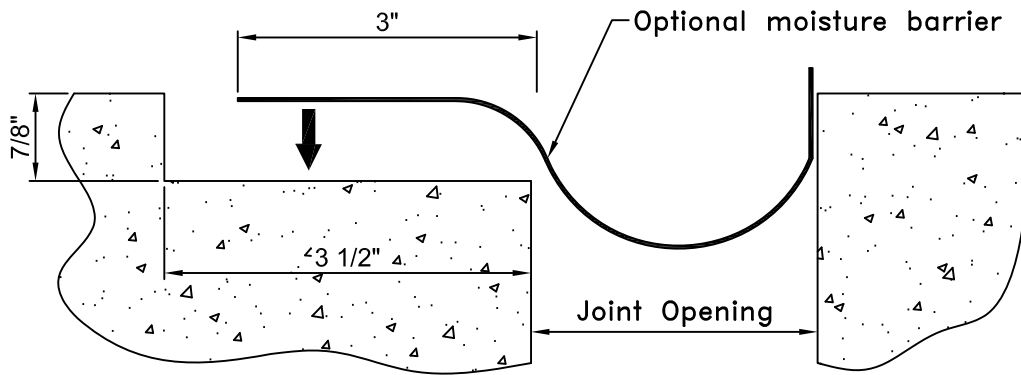

1

(Optional)
Position moisture barrier in to blockout. Maintain proper overlap and temporarily affix with duct tape (if required).

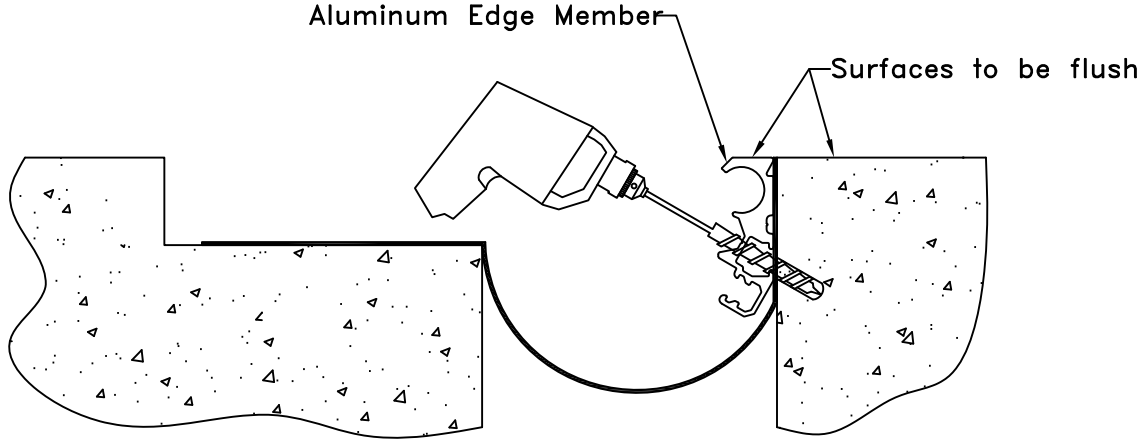

2

Position Aluminum Edge Assembly so that the top is Flush with the top of the Concrete Surface. Using base member as a template and with its position fixed, drill holes for 1/4" x 2 1/4" Tapcon anchor (PN:6526) spaced at 24" O.C. to the proper depth. Clean out holes and install anchor.

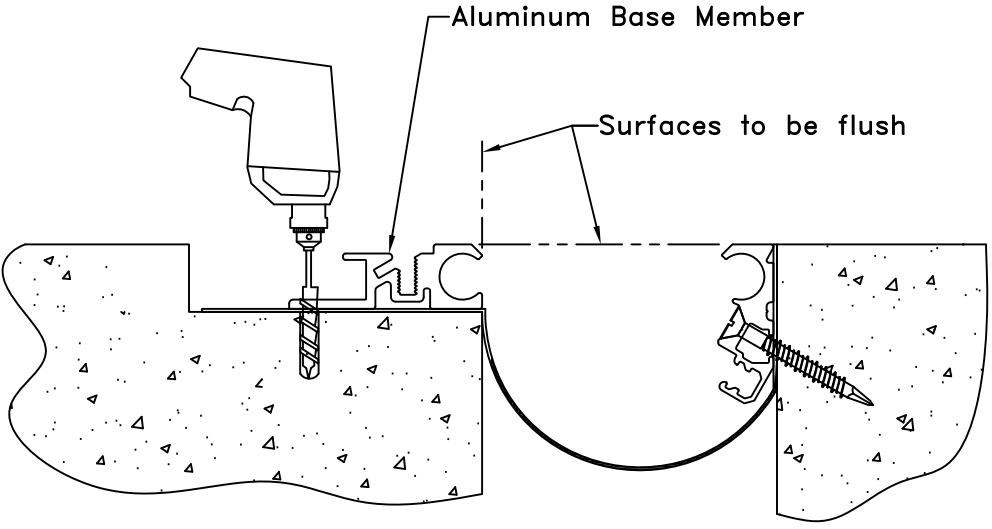

3

Position base member on block out so cavity of base member is flush with edge of opening. Using base member as a template and with its position fixed, drill holes for 1/4" x 2 1/4" Concrete anchor (PN:6581) spaced at 24" O.C. to proper depth. Clean out holes and install anchor. After base members have been installed, the contractor can cut the excess (Optional) Moisture Barrier flush with the face of the base member.

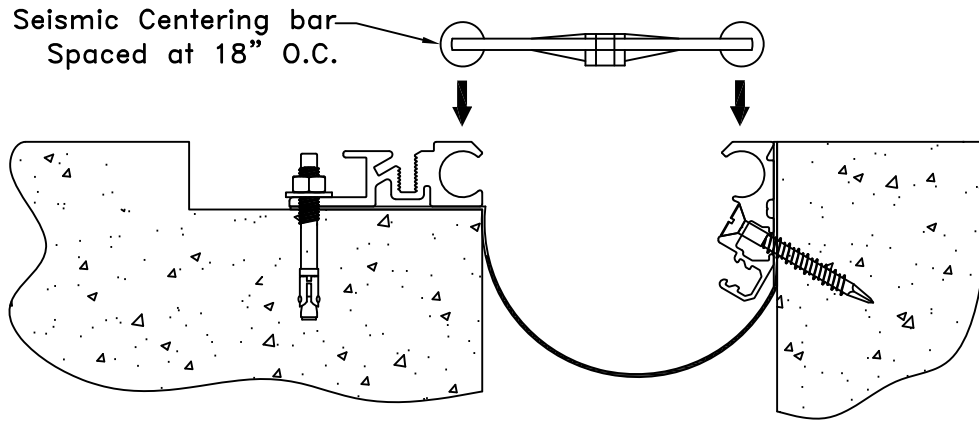

4

As work progresses with placement of base members, install self-centering bars by sliding the spherical ends of the bars into and through the circular cavities of the base members. Set at an approximate spacing of 18" O.C. Ensure that the "top" indicator is facing up and that all bars are in same orientation.

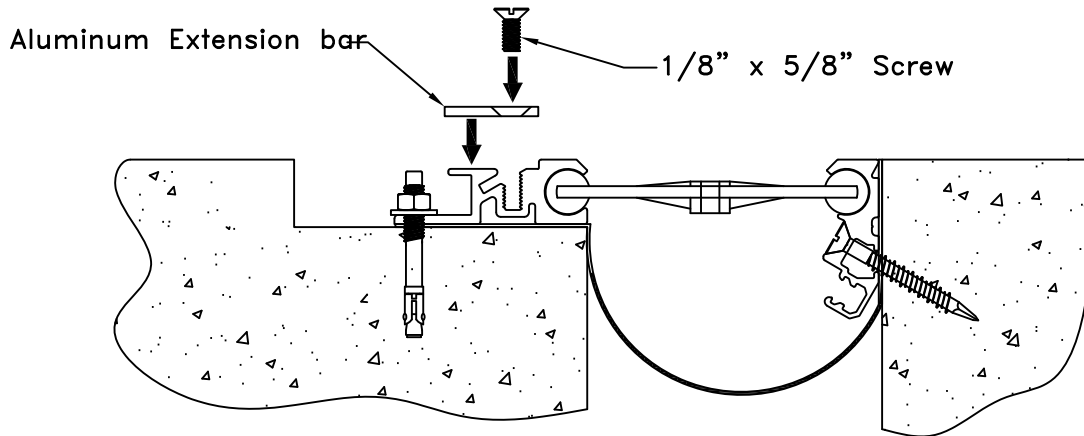

5

Place Aluminum Extension Bar into the recess in the Base Member and fasten with the 1/4" x 5/8" Long Screws spaced at 18" O.C.

Blockout Infill material
(By Others)

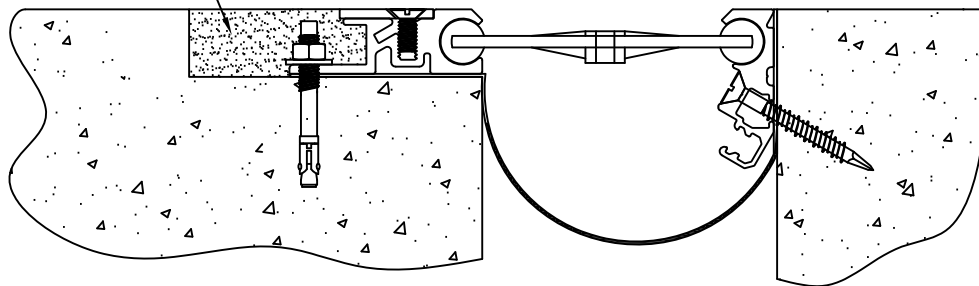

6

Fill block out with high quality non-shrink cementitious filler material. Protect surfaces during placement of filler material.

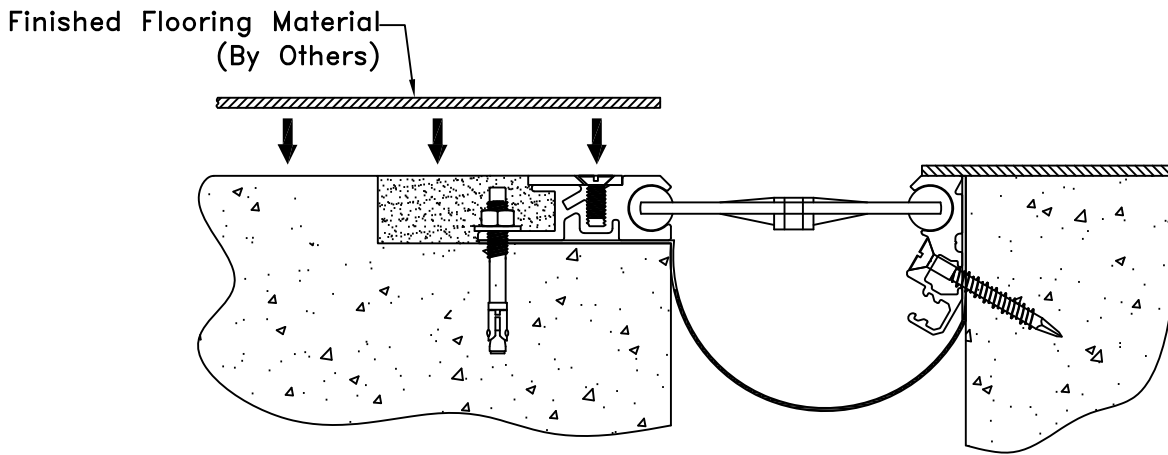

- 7** Install Finished Flooring material. Ensure flush installation with top of expansion joint system.
Caution – Contact flooring manufacturer to discuss application and procedure for proper installation.

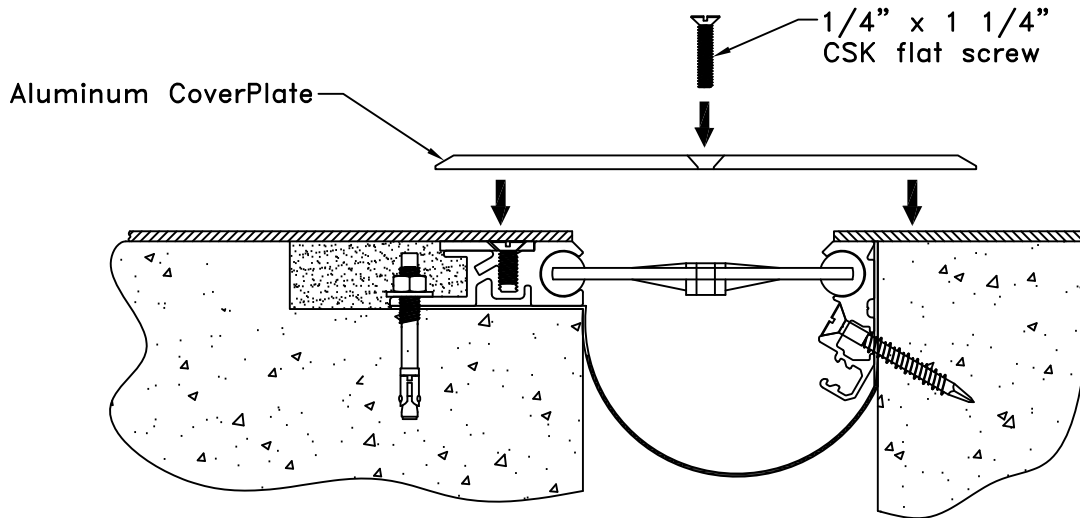

- 8** Position the center slide plate over expansion opening, align pre-drilled holes in slide plate with threaded insert in self-centering bars. Fasten with 1/4" x 1 1/4" CSK flat screw. Tighten to create measurable tension in the bar.



Erie Metal Specialties, Inc.
13311 Main Road
Akron, NY 14001
Phone: 716-542-3991
Fax: 716-542-3996
Email: sales@eriemetal.com
Website: www.eriemetal.com

SPECIFICATION

Section 07 95 13

Erie Metal Specialties, Interior Architectural Systems

Model(s) “ESFE”, “ESFB”

Seismic Floor Expansion Control Systems

PART 1 - GENERAL

1.01 Work Included

- A. The work shall consist of furnishing and installing expansion joints in accordance with the details shown on the plans and the requirements of the specifications. The joints are proprietary designs utilizing extruded elastomeric seals, aluminum base members and support plates.
- B. Related Work
 - Cast-in-place concrete
 - Miscellaneous and ornamental metals
 - Flashing and sheet metal

1.02 Submittals

- A. Template Drawings - Submit typical seismic joint cross-section(s) indicating pertinent dimensioning, general construction, component connections, and anchorage methods.

1.03 Product Delivery, Storage and Handling

- A. Deliver products in each manufacturer's original, intact, labeled containers and store under cover in a dry location until installed. Store off the ground, protect from weather and construction activities.

1.04 Acceptable Manufacturer

- A. All joints shall be supplied by; Erie Metal Specialties, Inc. • 13311 Main Road • Akron • New York • 14001 • Phone (716) 542-3991 • Fax (716) 542-3996 • sales@eriemetal.com • www.eriemetal.com .
- B. Alternate manufacturers and their products will be considered, provided they meet the design concept and are produced of materials that are equal to or superior to those specified.



Erie Metal Specialties, Inc.
13311 Main Road
Akron, NY 14001
Phone: 716-542-3991
Fax: 716-542-3996
Email: sales@eriemetal.com
Website: www.eriemetal.com

- C. Any proposed alternate systems must be submitted and receive approval 21 days prior to the bid. All post bid submittals will not be considered. This submission shall be in accordance with MATERIALS AND SUBSTITUTIONS.

- Any manufacturer wishing to submit for prior approval must provide the following:

A working 6" sample of the proposed system with a letter describing how system is considered superior to the specified system.

A project proposal drawing that illustrates the recommended alternate system installed in the floor construction that is specific to the project. Typical catalog cut sections will not be considered.

A Verifiable list of prior installations showing prior and successful experience with the proposed Systems.

Any substitution products not adhering to all specification requirements within, will not be considered.

1.05 Quality Assurance

- A. Warranty: The Professional Series expansion control system's performance shall be warranted for a period of 3 years when installed by the manufacturer's factory trained Certified Applicator. Installation shall be in strict accordance with manufacturer's technical specifications, details, installation instructions and general procedures in effect for normal intended usage and suitable applications under specified design movements and loading conditions.
- B. Manufacturer: Shall have a minimum ten (10) years experience specializing in the design and manufacture of Architectural Expansion Control Systems.
- C. Products: Expansion Control Systems must be installed with manufacturer's block out repair and infill material(s).
- D. Application: The specified expansion control systems shall be installed by a Certified Applicator, factory trained and certified in the proper installation of the specified expansion control system and fire barrier system.
- E. Maintenance: The manufacturer shall provide the owner-operator a preventive maintenance guideline for Expansion Control Systems.

PART 2 - PRODUCT

2.01 General

- A. Provide floor joint cover expansion control system that can accommodate multi-directional seismic movement without stress to its components. System shall consist of metal profiles that utilize various metal finishes with a choice of aluminum base members designed to accommodate various project conditions and finish floor treatments. The cover plate shall be designed of width and thickness required to satisfy projects movement and loading requirements. Secure cover



Erie Metal Specialties, Inc.
 13311 Main Road
 Akron, NY 14001
 Phone: 716-542-3991
 Fax: 716-542-3996
 Email: sales@eriemetal.com
 Website: www.eriemetal.com

plate to base members by utilizing manufacturer’s pre-engineered seismic-centering bar. Anchor floor joint cover system to floor slab selecting one of the manufacturer’s appropriate anchoring systems.

Furnish EMS, Model(s) “ESFE” and “ESFB” floor joint cover meeting ADA Guidelines for pedestrian areas in interior and exterior joint locations as indicated on drawings. Select model based on project requirements.

2.02 Components and Materials

- A. Aluminum Extrusions - Material to conform to properties of ASTM B221, alloy 6061-T6 or 6063-T5.
- B. Aluminum Shapes - Material to conform to ASTM B209, alloy 6061-T6, or 5005-H34.
- C. Slide Plate - Provide minimum 3/16” thick plate with material to be aluminum conforming to ASTM B209, alloy 6061-T6. Where loading requirements do not dictate a structural alloy, utilize 5005-H34 for slide plate installed in a floor to wall condition. Slide plate to be secured to joint assembly utilizing a pre-engineered self-centering bar that freely rotates in all directions. Preformed metal devices that utilize tension or compression to maintain and secure slide plate will not be allowed.
- D. Seismic-Centering Bar - Shall exhibit circular sphered ends that lock and slide inside the corresponding aluminum extrusion cavity to allow freedom of movement and flexure in all directions including vertical displacement. Bar shall be molded or manufactured incorporating corrosion resistant nylon components with sphered ends and 1” wide standard cross member for standard applications. Provide 1 1/2” wide cross member where heavy-duty application is required. Spacing shall be a maximum of 18” o.c.

During seismic activity design centering bar to permit vertical displacement of metal cover during accelerated inward and outward movement without evidence of fatigue and permanent deformation. Concurrently provide secure connection between plate and underlying system components to maintain proper positioning and contact to adjoining surfaces.

Bar shall exhibit the following physical properties to demonstrate ability to resist corrosion and fatigue.

PHYSICAL PROPERTIES

Molded End Profile:

Material:	Nylon
Color:	Black
Tensile Strength @ break:	ASTM D638 25,500 psi

Cross-Member:

Material:	Pre-tempered spring steel
-----------	---------------------------



Erie Metal Specialties, Inc.
 13311 Main Road
 Akron, NY 14001
 Phone: 716-542-3991
 Fax: 716-542-3996
 Email: sales@eriemetal.com
 Website: www.eriemetal.com

Damage Mitigation - Test Requirements:

Seismic-centering bar must exhibit ability to disengage (controlled release) from expansion joint edge member(s) when seismic movement exceeds the specified maximum allowable opening. Submit independent test report demonstrating required design of seismic-centering bar.

Requirements

- a) Equipment: Instron Machine
- b) Orientation: Specimen subjected to tensile load with crossmember parallel to direction of load.
- c) Specimens: Test 4(min) – select at random
- d) Disengagement range (lbs): 800 (min.) – 1250 (max.)

- E. Moisture Barrier - Shall be a fabric reinforced tear resistant clean vinyl sheet material. Minimum Thickness shall be .026”.
- F. Anchorage - Provide minimum 1/4” diameter anchor at maximum 24” o.c. spacing. Type of anchor and method of attachment to be determined by project conditions.
- G. Block out Repair - Utilize manufacturer’s single component rapid strength repair mortar meeting the following data requirements.

Compressive strength, psi (ASTM C 109)

2 hours	1,500
24 hours	4,500
7 days	8,000
28 days	9,000

- H. Block out Infill - Utilize manufacturer’s non-catalyzed, non-shrink grout containing mineral aggregate meeting the following data requirements.

Compressive strength at plastic consistency, psi

3 days	6,000
7 days	7,000
28 days	8,500

- I. Accessories - Provide necessary and related parts, and fasteners required for complete installation.



Erie Metal Specialties, Inc.
13311 Main Road
Akron, NY 14001
Phone: 716-542-3991
Fax: 716-542-3996
Email: sales@eriemetal.com
Website: www.eriemetal.com

- J. Fire Barrier Assembly - Designed for indicated or required dynamic structural movement without material degradation or fatigue. Tested in maximum joint width conditions with a field splice as a component of the expansion joint cover in accordance with ASTM E-119 at full rated period by a nationally recognized testing and inspecting organization. Supply Erie Metal's Fire Barrier as governed by joint opening and fire rating.

2.03 Fabrication

- A. Extrusions and generic profiles to be shipped in standard 10 ft. lengths and shall be cut to length on jobsite where required. Profiles shall be miter cut in the field to conform to directional changes unless otherwise contracted with expansion joint manufacturer.
- B. Fire Barriers - Ship manufacturer's standard assembly including fire caulks, sealants (if applicable) and hardware for the required hourly rating. Assemblies shall be miter cut in the field to accommodate changes in direction.

2.04 Finishes (Standard)

- A. The cover plate's exposed surface shall receive a 60-grit brushed finish. All other aluminum extrusions and shapes shall be supplied in standard mill finish.
- B. Surfaces of aluminum profiles that will be in direct contact with concrete where moisture is present shall receive one coat of manufacturer's recommended coating.

PART 3 - EXECUTION

3.01 Installation

- A. Install all Expansion Control Systems utilizing manufacturer's block out repair and infill material(s).
- B. Protect all expansion joint component parts from damage during installation, placement of concrete and thereafter until completion of structure.
- C. Expansion joint systems shall be installed in strict accordance with the manufacturer's typical details and instructions along with the advice of their qualified representative.
- D. Expansion joint systems shall be set to the proper width for the ambient temperature at the time of installation. This information is indicated in the contract plans.

3.02 Clean and Protect

- A. Protect system and its components during construction. After work is complete in adjacent areas clean exposed surfaces with a suitable cleaner that will not harm or attack the finish.

Note:

- For openings up to 6"
- Plate supplied with grooved surface/mill finish
- For openings greater than 6"
- Plate supplied with brush finish
- Grooves optional for plates up to 24" in width

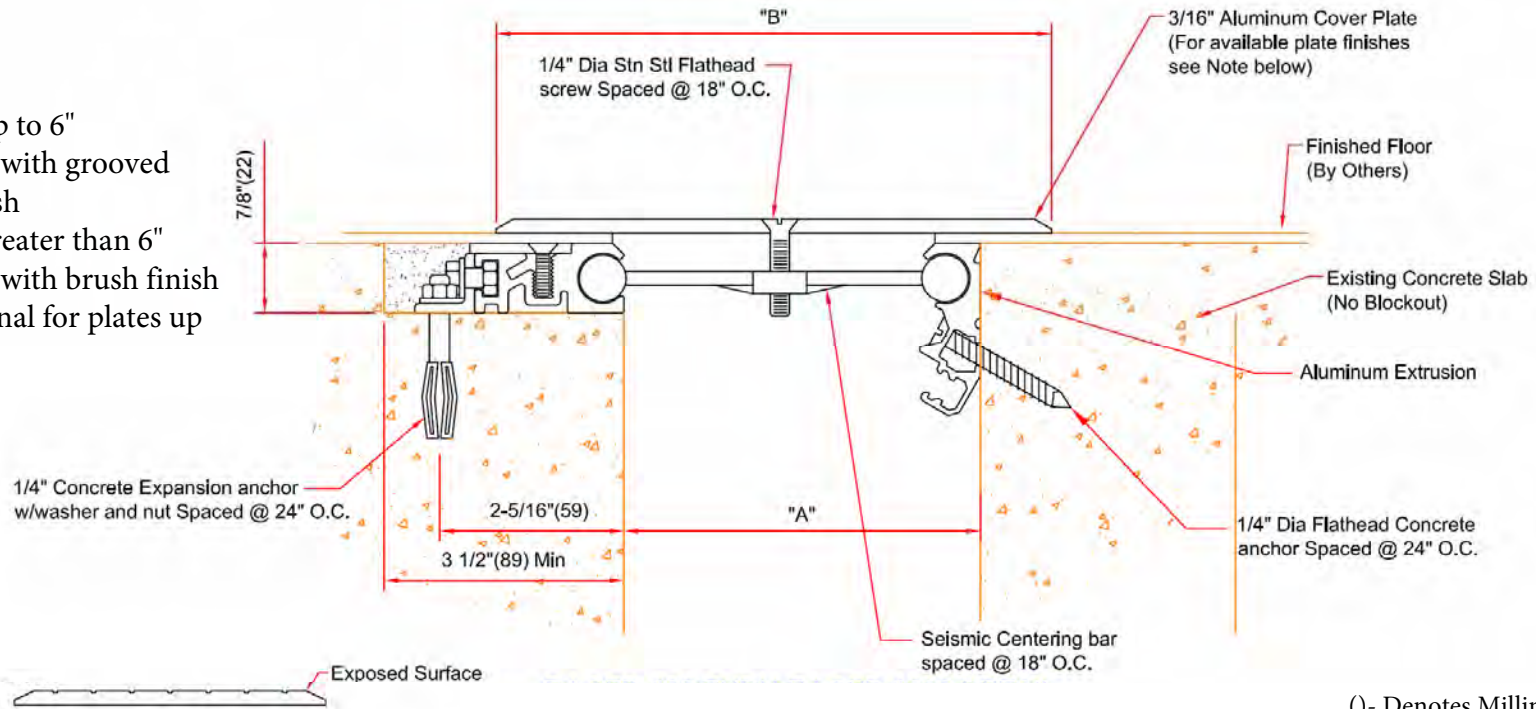

(-) Denotes Millimeters

**ESFB-400 THRU ESFB-1800 DETAIL
FLOOR TO FLOOR CONDITION**

DIMENSION CHART					
MODEL	"A" @ Min	"A" @ Mid	"A" @ Max	"B"	TOTAL MOVEMENT
ESFB-400	1" (25)	4" (102)	6" (152)	6 1/2" (165)	5" (127)
ESFB-600	1" (25)	6" (152)	9" (229)	9 1/2" (241)	8" (203)
ESFB-800	1" (25)	8" (203)	12" (305)	12 1/2" (317)	11" (279)
ESFB-1000	1" (25)	10" (254)	15" (381)	15 1/2" (470)	14" (356)
ESFB-1200	1" (25)	12" (305)	18" (457)	18 1/2" (470)	17" (432)
ESFB-1800	1" (25)	18" (457)	27" (686)	27 1/2" (699)	26" (660)

Note: Minimum and Maximum values are after movement occurs. Mid point value is the recommended size of opening at installation

NO.	Description	Date	By
The information contained herein is the proprietary property of ERIE METAL SPECIALTIES, INC. No portion of it may be reproduced by any means or used in any form except for the purpose for which it was intended. All rights of design and invention are hereby reserved.			



13311 Main Road • Akron • New York • 14001
Phone: (716) 542-3991 • Fax: (716) 542-3996 • E-mail: sales@eriemetal.com

PROJECT:

TITLE:

Detailed by: BAF	Date: 10/21/17
Checked By: SLP	Date: 10/21/17
Scale: NTS	EMS Job #:
Sheet No.: 1 of 1	Drawing No.: