



# SUBSTITUTION REQUEST

(After the Bidding/Negotiating Phase)

Project: \_\_\_\_\_ Substitution Request Number: \_\_\_\_\_  
 \_\_\_\_\_  
 From: \_\_\_\_\_  
 To: \_\_\_\_\_ Date: \_\_\_\_\_  
 \_\_\_\_\_  
 A/E Project Number: \_\_\_\_\_  
 Re: \_\_\_\_\_ Contract For: \_\_\_\_\_

Specification Title: \_\_\_\_\_ Description: \_\_\_\_\_  
 Section: \_\_\_\_\_ Page: \_\_\_\_\_ Article/Paragraph: \_\_\_\_\_

Proposed Substitution: \_\_\_\_\_  
 Manufacturer: \_\_\_\_\_ Phone: \_\_\_\_\_  
 Address: \_\_\_\_\_  
 Trade Name: \_\_\_\_\_ Model No.: \_\_\_\_\_  
 Installer: \_\_\_\_\_ Phone: \_\_\_\_\_  
 Address: \_\_\_\_\_

History:  New product  1-4 years old  5-10 years old  More than 10 years old

Differences between proposed substitution and specified product: \_\_\_\_\_  
 \_\_\_\_\_  
 \_\_\_\_\_

Point-by-point comparative data attached — REQUIRED BY A/E

Reason for not providing specified item: \_\_\_\_\_  
 \_\_\_\_\_

### Similar Installation:

Project: \_\_\_\_\_ Architect: \_\_\_\_\_  
 Address: \_\_\_\_\_ Owner: \_\_\_\_\_  
 \_\_\_\_\_ Date Installed: \_\_\_\_\_

Proposed substitution affects other parts of Work:  No  Yes; explain \_\_\_\_\_  
 \_\_\_\_\_

Savings to Owner for accepting substitution: \_\_\_\_\_ (\$ \_\_\_\_\_).

Proposed substitution changes Contract Time:  No  Yes [Add] [Deduct] \_\_\_\_\_ days.

Supporting Data Attached:  Drawings  Product Data  Samples  Tests  Reports  \_\_\_\_\_

# SUBSTITUTION REQUEST

(After the Bidding/Negotiating Phase — Continued)

---

The Undersigned certifies:

- Proposed substitution has been fully investigated and determined to be equal or superior in all respects to specified product.
  - Same warranty will be furnished for proposed substitution as for specified product.
  - Same maintenance service and source of replacement parts, as applicable, is available.
  - Proposed substitution will have no adverse effect on other trades and will not affect or delay progress schedule.
  - Cost data as stated above is complete. Claims for additional costs related to accepted substitution which may subsequently become apparent are to be waived.
  - Proposed substitution does not affect dimensions and functional clearances.
  - Payment will be made for changes to building design, including A/E design, detailing, and construction costs caused by the substitution.
  - Coordination, installation, and changes in the Work as necessary for accepted substitution will be complete in all respects.
- 

Submitted by: \_\_\_\_\_

Signed by: \_\_\_\_\_

Firm: \_\_\_\_\_

Address: \_\_\_\_\_

Telephone: \_\_\_\_\_

Attachments:

---

## A/E's REVIEW AND ACTION

- Substitution approved - Make submittals in accordance with Specification Section 01 25 00 Substitution Procedures.
- Substitution approved as noted - Make submittals in accordance with Specification Section 01 25 00 Substitution Procedures.
- Substitution rejected - Use specified materials.
- Substitution Request received too late - Use specified materials.

Signed by: \_\_\_\_\_ Date: \_\_\_\_\_

---

Additional Comments:  Contractor  Subcontractor  Supplier  Manufacturer  A/E  
 Other:

# ELCF/S/C/T Series Floor System

## Interior Joints (Floor)

This Elastomeric System is built to last. The system's extruded aluminum base is installed in a concrete block out channel and backfilled in. Integrated into the system is a colored rubber seal that expands and compresses with horizontal movement.

### FEATURES

**COORDINATING CORNERS** Available with corner option for a complete floor solution.

**CONTINUOUS SIGHT LINE** Available with coordinating wall and ceiling systems to provide an aesthetically pleasing appearance.

**COMPLEMENTARY SEAL COLORS** Available in four elastomeric seal color options: beige, white, gray or black.



### DETAILS

**MATERIAL** 6063-T6 Aluminum

**FINISH** Mill and Rubber Seal

#### MOVEMENT

- Thermal: Horizontal

**MOUNTING** Block Out or Surface

**JOINT SIZE** 1 inch or 2 inches

**LENGTH** 10 Linear Feet

**LOAD** Pedestrian and Light Cart

**INSTALLATION** Floor

**OPTIONS** Seal Color, Moisture Barrier, Fire Barrier

### MODELS

MODEL	INSTALLATION	JOINT SIZE AT MEAN T°F	SYSTEM WIDTH	TOTAL MOVEMENT
ELCF-100	Floor-to-Floor	1" (25mm)	1.5" (40mm)	.5" (12mm)
ELCF-100W	Floor-to-Wall	1" (25mm)	2" (50mm)	.5" (12mm)
ELCF-200	Floor-to-Floor	2" (50mm)	2" (50mm)	1" (25mm)
ELCF-200W	Floor-to-Wall	2" (50mm)	3" (75mm)	1" (25mm)

### SEAL COLORS

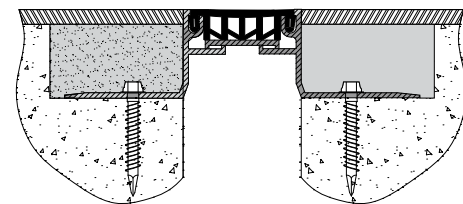

Floor-to-Floor

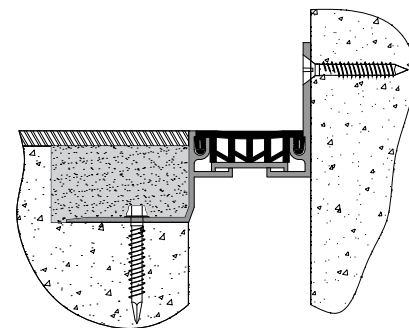

Floor-to-Wall/Corner



Erie Metal Specialties, Inc.  
13311 Main Road  
Akron, NY 14001

Phone: 716-542-3991  
Website: [www.eriametal.com](http://www.eriametal.com)  
E-Mail: [sales@eriametal.com](mailto:sales@eriametal.com)

# ELCF/S/C/T Series Floor System (Cont.)

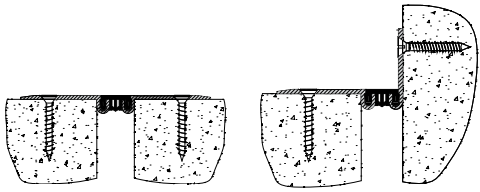

Floor-to-Floor

Floor-to-Wall/Corner

## DETAILS

**MOUNTING** Surface

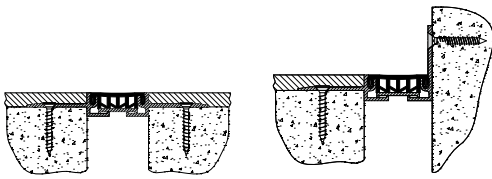

Floor-to-Floor

Floor-to-Wall/Corner

## DETAILS

**MOUNTING** Surface

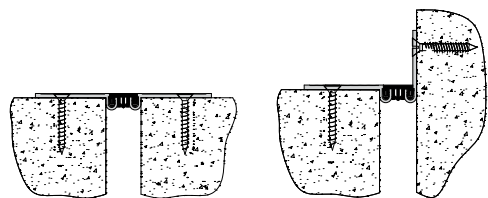

Floor-to-Floor

Floor-to-Wall/Corner

## DETAILS

**MOUNTING** Surface

## ELFS/W Top Mount Application

The Top Mount System is designed for mounting directly over the expansion joint on top of the flooring material. The beveled edge provides smooth transition walking surface.

### MODELS

MODEL	INSTALLATION	JOINT SIZE AT MEAN T°F	SYSTEM WIDTH	TOTAL MOVEMENT
ELCFS-100	Floor-to-Floor	1" (25mm)	5" (127mm)	0.5" (13mm)
ELCFS-100W	Floor-to-Wall	1" (25mm)	2.75" (70mm)	0.5" (13mm)
ELCFS-200	Floor-to-Floor	2" (51mm)	6" (152mm)	1" (25mm)
ELCFS-200W	Floor-to-Wall	2" (51mm)	3.78" (96mm)	1" (25mm)

## ELCFC/W Flooring Infill Application

Flooring Infill Elastomeric Expansion Joint System is a surface mounted system that is designed for mounting directly over the expansion joint and receives flooring on top of the installed assembly.

### MODELS

MODEL	INSTALLATION	JOINT SIZE AT MEAN T°F	SYSTEM WIDTH	TOTAL MOVEMENT
ELCFC-100	Floor-to-Floor	1" (25mm)	1" (25mm)	0.5" (13mm)
ELCFC-100W	Floor-to-Wall	1" (25mm)	1" (25mm)	0.5" (13mm)
ELCFC-200	Floor-to-Floor	2" (51mm)	2" (51mm)	1" (25mm)
ELCFC-200W	Floor-to-Wall	2" (51mm)	2" (51mm)	1" (25mm)

## ELCFT/W Tile Application

This system is designed to be mounted directly over the joint openings for tile applications. The flooring mounts flush to the edge of the assembly.

### MODELS

MODEL	INSTALLATION	JOINT SIZE AT MEAN T°F	SYSTEM WIDTH	TOTAL MOVEMENT
ELCFT-100	Floor-to-Floor	1" (25mm)	5" (127mm)	0.5" (13mm)
ELCFT-100W	Floor-to-Wall	1" (25mm)	2.78" (71mm)	0.5" (13mm)
ELCFT-200	Floor-to-Floor	2" (51mm)	6" (152mm)	1" (25mm)
ELCFT-200W	Floor-to-Wall	2" (51mm)	3.78" (96mm)	1" (25mm)





Erie Metal Specialties, Inc.  
13311 Main Road  
Akron, NY 14001

Phone: 716-542-3991  
Website: [www.eriametal.com](http://www.eriametal.com)  
E-Mail: [sales@eriametal.com](mailto:sales@eriametal.com)

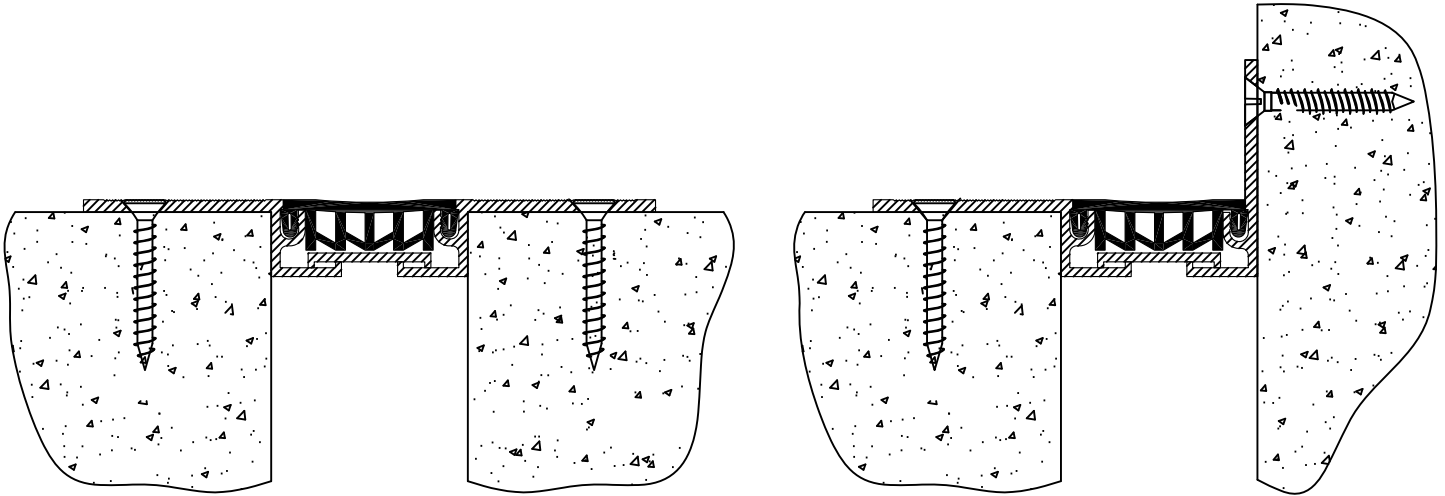

## Seal Flooring - Standard Series Model(s) "ELCFT-100/200" & "ELCFT-100W/200W" Horizontal Expansion Control Systems

The following installation procedure is very important and must be fully understood prior to beginning any work. To ensure proper installation and performance of expansion joint system the following actions must be completed by the installing contractor. Failure to do so will affect product warranty.

- 1) Carefully read and understand installation procedure. Contact Technical Service Department for product assistance.
- 2) Inspect all shipments and materials for missing or damaged components and hardware. Contact Customer Service with order number and invoice for prompt assistance.
- 3) Inspect substrate or adjacent construction for acceptance before beginning work. Report unacceptable construction to the project manager for scheduled repair work.

PN: 28044A

# Standard Components

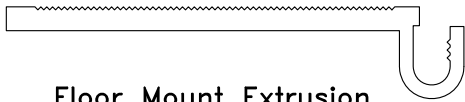

Floor Mount Extrusion  
Part Number-27419  
(for ELCFT-100/100W)



\*Wall Mount Extrusion  
Part Number-27478  
(for ELCFT-100W)

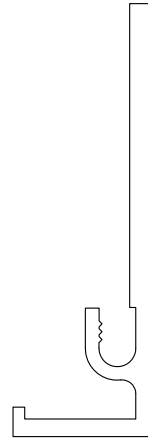

\*Wall Mount Extrusion  
Part Number-27418  
(for ELCFT-200W)

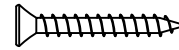

#12 x 1 3/4" Spax Anchor  
Part Number-27506



Aluminum Support Plate  
Part Number-27382  
(for ELCFT-200/200W)

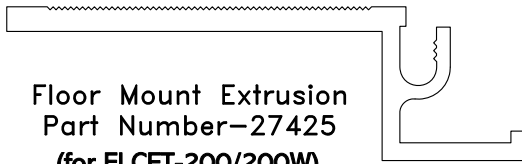

Floor Mount Extrusion  
Part Number-27425  
(for ELCFT-200/200W)

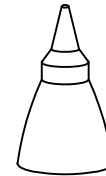

\*\*SI 750 Adhesive  
Part Number - 27514

\*Components required for corner condition

\*\*Optional components for splice procedures. Place order for required quantities.

Components shown below vary in size depending on model of system

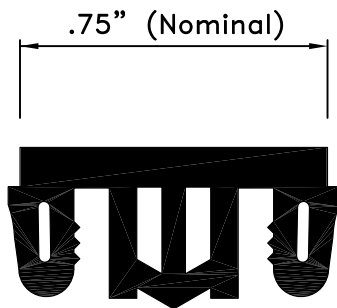

ELCFT-100/100W

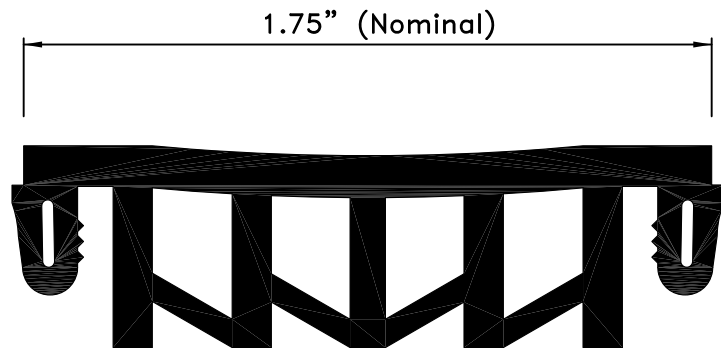

ELCFT-200/200W

Seal Part Number				
Model	Black Seal	White Seal	Grey Seal	Beige Seal
ELCFT-100/100W	28001	28002	28003	28004
ELCFT-200/200W	28005	28006	28007	28008

# Installation Procedure

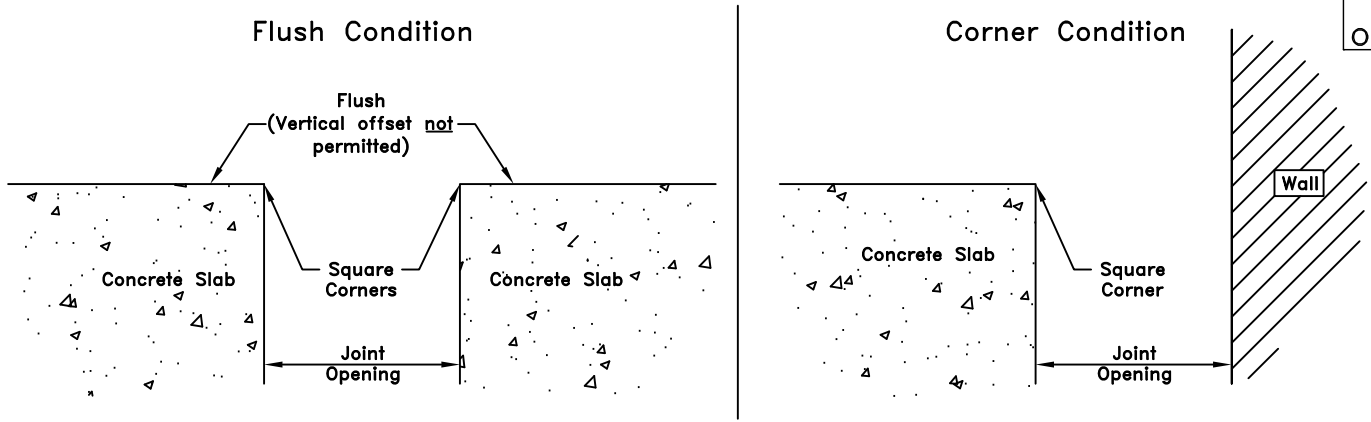

**1** Prior to beginning work, installer shall inspect corners of concrete slab for acceptability. For repair (if required) refer to step 2, also, measure joint opening for proper size as called for on shop drawings or cad detail.

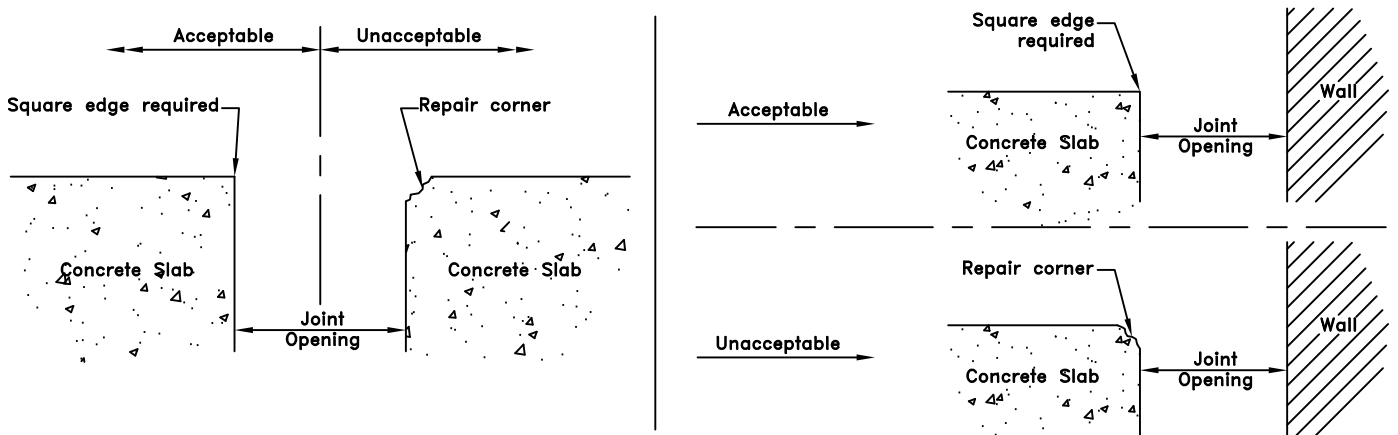

**2** Repair corner of concrete slab following manufacturers instructions.

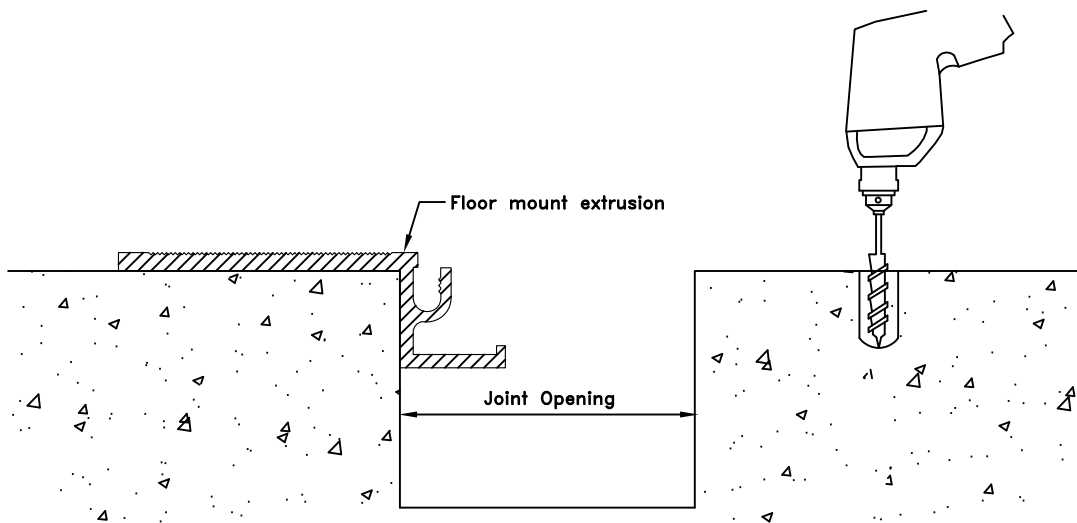

**3** Position aluminum extrusions on both sides of joint opening. Use 2" section of seal on both ends of extrusion as gauge to ensure proper separation. Mark hole locations and drill for #12 spax anchors.

**Note A:**  
Opening between aluminum extrusions must be set accurately to ensure seals proper installation.

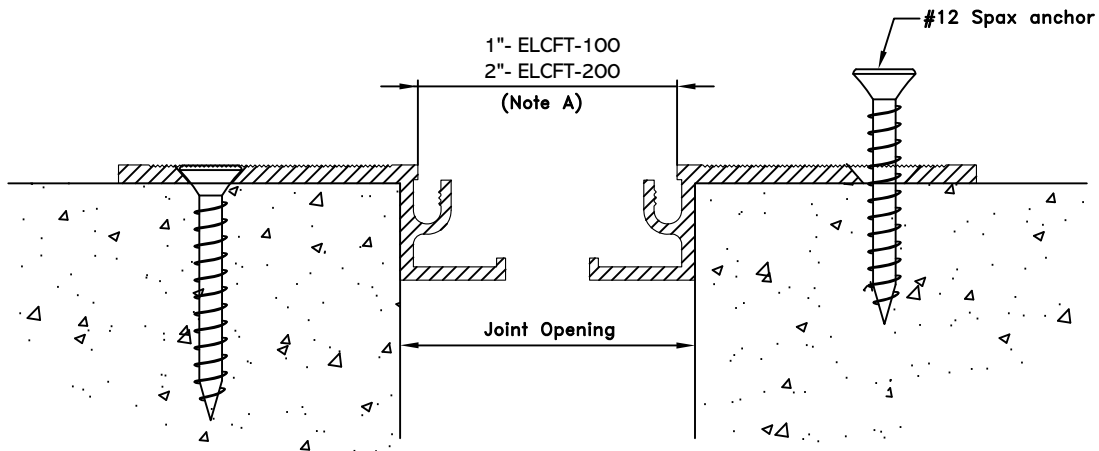

**4** Mount and secure extrusions to slab with #12 spax anchors.

### Corner Condition

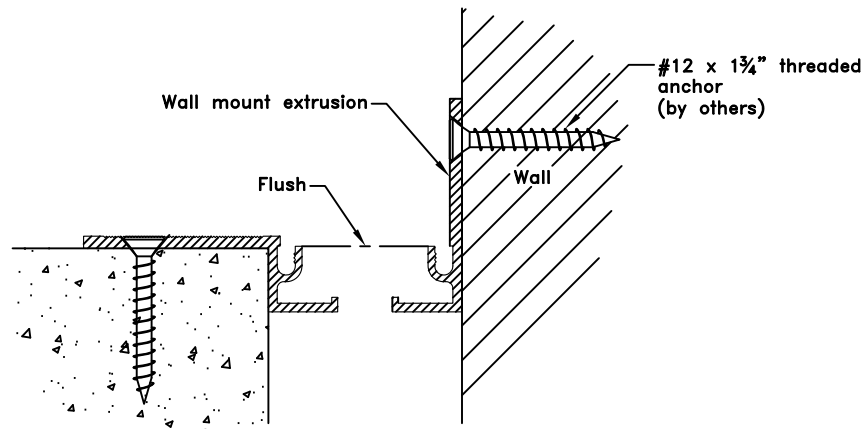

**4A** Secure extrusion to slab by using #12 spax anchor. Use 2" section of seal on both ends of extrusion as gauge to ensure proper separation. Along corner condition use screw anchor to mount wall extrusion to wall (supplied by others).

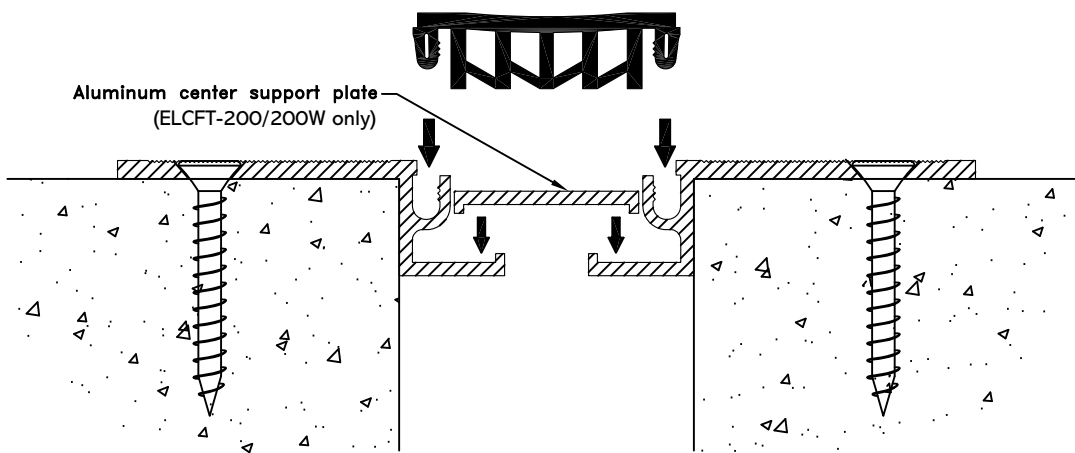

**5** Squeeze or slide elastomeric seal into aluminum extrusion.



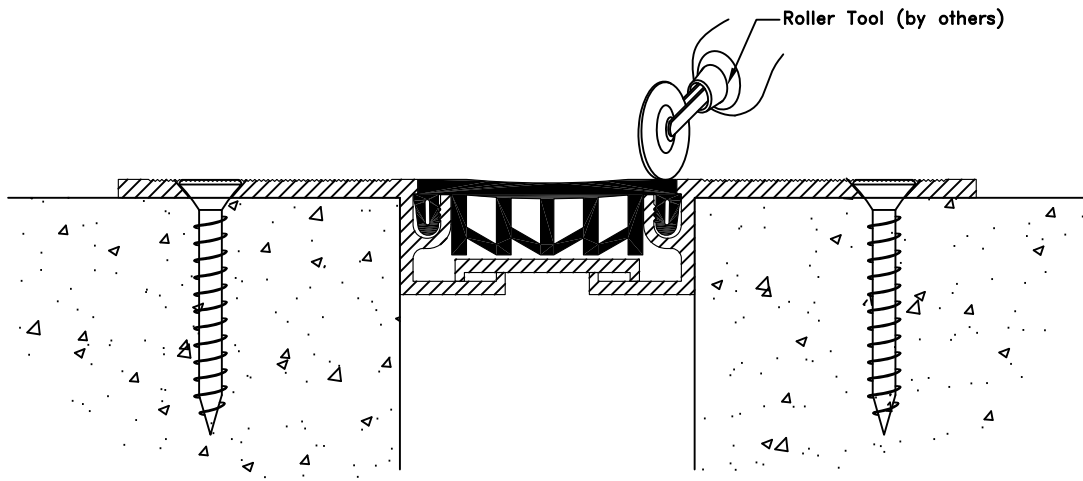

**6** Utilizing roller tool apply pressure directly over locking lug to ensure proper engagement of seal lug.

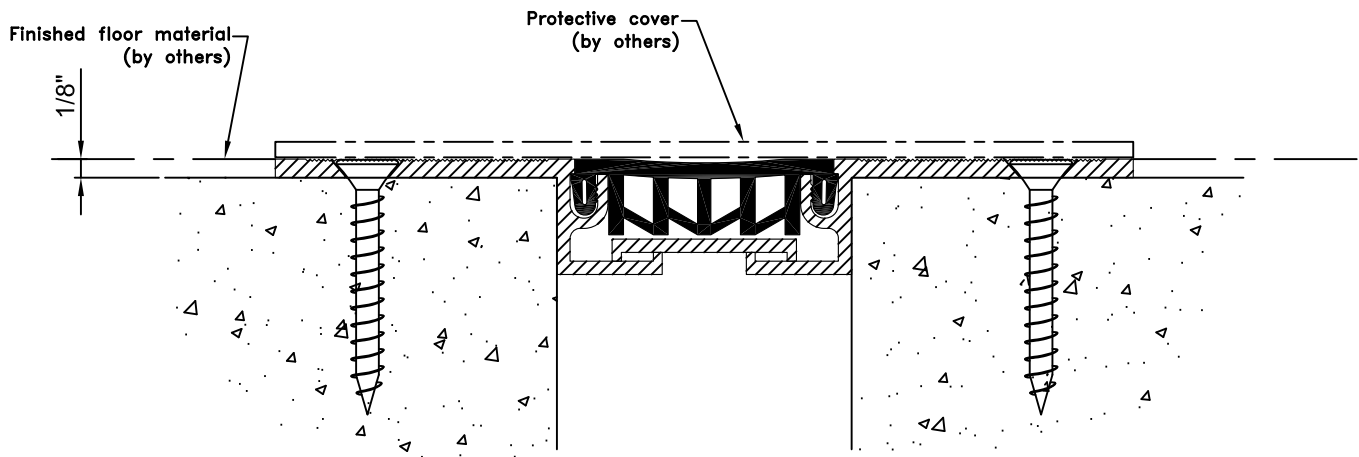

**7** Following manufacturers installation procedures install finish flooring materials. Ensure Flush installation with top of expansion joint system.  
Note: Protect expansion joint finish during installation of finish flooring materials. Also keep protection on expansion joint system during construction activities.

# Suggested Field Splice Procedure

1. Cut ends of seal with a sharp knife and miter box to the desired angle. Insure that cuts are clean and straight.
2. Clean ends of seal with a solvent.
3. Apply SI 750 Adhesive to one of the two seal ends to be bonded.
4. Apply pressure bringing the two surfaces into tight contact immediately after adhesive is applied. Hold in place for one to two minutes for initial bond.
5. Re-Check quality of all splices/miters and apply adhesive as required.
7. It is usually recommended to allow 15 minutes prior to installing seal. To achieve proper working strength care shall be exercised as a result that it takes 24 hours for adhesive to fully cure.

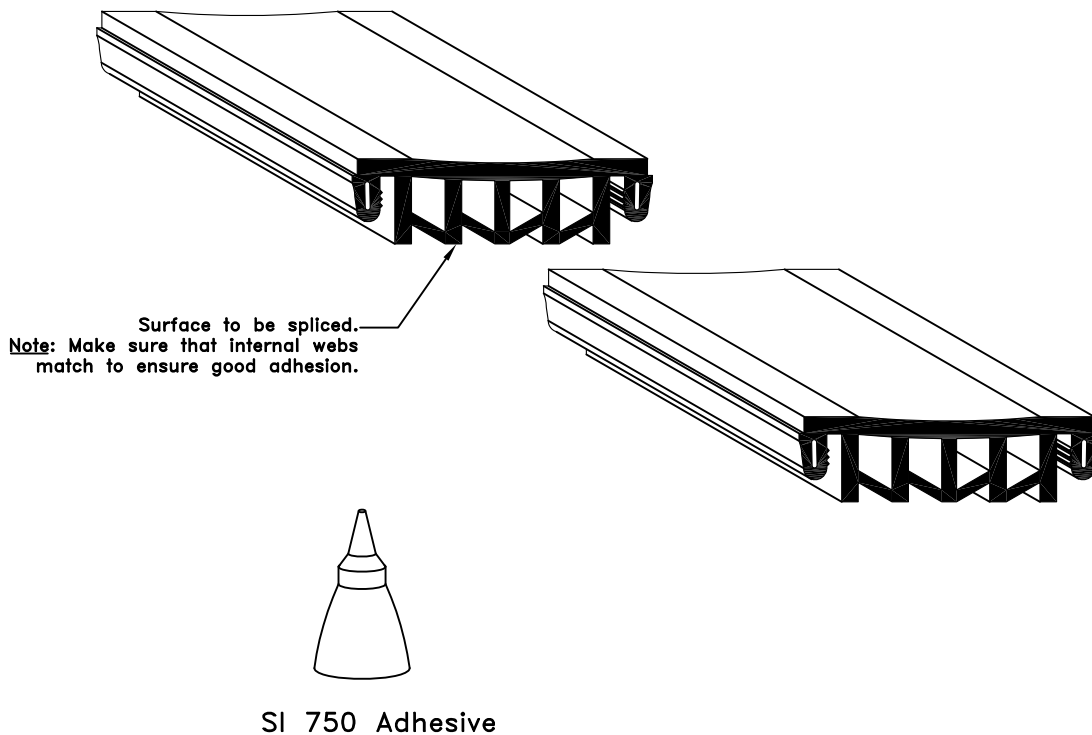



Erie Metal Specialties, Inc.  
13311 Main Road  
Akron, NY 14001  
Phone: 716-542-3991  
Fax: 716-542-3996  
E-mail: [sales@eriemetal.com](mailto:sales@eriemetal.com)  
Website: [www.eriemetal.com](http://www.eriemetal.com)

## **SPECIFICATION**

### **Section 07 95 13**

#### **Erie Metal Specialties, Interior Architectural Systems**

#### **Model(s) “ELCF”, “ELCFC”, “ELCFS”, “ELCFT”**

#### **Horizontal Expansion Control Systems**

#### **PART 1 - GENERAL**

##### **1.01 Work Included**

- A. The work shall consist of furnishing and installing expansion joints in accordance with the details shown on the plans and the requirements of the specifications. The joints are proprietary designs utilizing extruded elastomeric seals, base members and support plates.
- B. Related Work
  - Cast-in-place concrete
  - Miscellaneous and ornamental metals
  - Flashing and sheet metal
  - Sealants and caulking

##### **1.02 Submittals**

- A. Template Drawings- Submit typical expansion joint cross-section(s) indicating pertinent dimensioning, general construction, component connections, and anchorage methods.

##### **1.03 Product Delivery, Storage and Handling**

- A. Deliver products in each manufacturer's original, intact, labeled containers and store under cover in a dry location until installed. Store off the ground, protect from weather and construction activities.

##### **1.04 Acceptable Manufacturer**

- A. All joints shall be supplied by; Erie Metal Specialties, Inc. • 13311 Main Road • Akron • New York • 14001 • Phone (716) 542-3991 • Fax (716) 542-3996 • [sales@eriemetal.com](mailto:sales@eriemetal.com) • [www.eriemetal.com](http://www.eriemetal.com) .
- B. Alternate manufacturers and their products will be considered, provided they meet the design concept and are produced of materials that are equal to or superior to those specified.



Erie Metal Specialties, Inc.  
13311 Main Road  
Akron, NY 14001  
Phone: 716-542-3991  
Fax: 716-542-3996  
E-mail: [sales@eriemetal.com](mailto:sales@eriemetal.com)  
Website: [www.eriemetal.com](http://www.eriemetal.com)

- C. Any proposed alternate systems must be submitted and receive approval 21 days prior to the bid. All post bid submittals will not be considered. This submission shall be in accordance with MATERIALS AND SUBSTITUTIONS.

- Any manufacturer wishing to submit for prior approval must provide the following:

A working 6" sample of the proposed system with a letter describing how system is considered superior to the specified system.

A project proposal drawing that illustrates the recommended alternate system installed in the floor construction that is specific to the project. Typical catalog cut sections will not be considered.

A Verifiable list of prior installations showing prior and successful experience with the proposed Systems.

Any substitution products not adhering to all specification requirements within, will not be considered.

## **PART 2 - PRODUCT**

### **2.01 General**

- A. Provide a low-profile expansion joint system that has been designed to accommodate new or existing construction. Incorporate a colorable elastomeric seal that demonstrates ability to remain flat during normal movement cycles. Provide a complete system that exhibits a flush transition between opposing slabs and adjacent finish floor surfaces that complies with ADA guidelines.

Furnish EMS Inc., Low Profile-Floor (Model "ELCF"), Plaza (Model "ELCFS") carpet (Model "ELCFC") or tile (Model "ELCFT") Expansion Control System for interior floors as indicated on drawings.

### **2.02 Components and Materials**

- A. Aluminum Extrusions - Design low height profile with cavity to receive locking lug of elastomeric profile. Provide alternate profiles for concrete slabs with and without blockouts. Where surface mounted profiles are utilized, provide non-slip walking surface designed with a tapered edge to meet the finish floor surface. Material to conform to properties of ASTM B221, alloy 6061-T6 or 6063 T-5.
- B. Aluminum Shapes - Material to conform to ASTM B209, alloy 6061-T6 or 5005-H34.
- C. Elastomeric Seals - Material shall be a flexible extruded Santoprene or manufacturer's alternate material exhibiting a shore A hardness of 64 +/- 5 with U.V. stabilizer. Provide multi-cellular profile with internal webs that form a truss-like structure that transfers service loads to adjacent aluminum extrusions without the need for support plates. The profile shall be flexible and exhibit a non-slip exposed surface that remains flat during normal movement cycles.



Erie Metal Specialties, Inc.  
 13311 Main Road  
 Akron, NY 14001  
 Phone: 716-542-3991  
 Fax: 716-542-3996  
 E-mail: [sales@eriemetal.com](mailto:sales@eriemetal.com)  
 Website: [www.eriemetal.com](http://www.eriemetal.com)

- D. Anchorage - Provide 1/4" (#12) diameter x 1 3/4" lg. (min.) threaded concrete anchor. Style of anchor and head configuration will be determined by type of extrusion profile utilized. Spacing shall be 24" c.c. maximum for block out condition and 24" c.c. for surface mounted profiles without block outs.
- E. Accessories - Provide necessary and related parts required for complete installation. Where project requirements dictate watertight performance, utilize manufacturer's standard adhesives and bedding compounds to install the system's components.
- F. Block out Repair (recommended) - Utilize single component rapid strength repair mortar meeting the following data requirements.

Compressive strength, psi (ASTM C 109)

2 hours	1,500
24 hours	4,500
7 days	8,000
28 days	9,000

- G. Block out Infill (recommended) - Utilize a non-catalyzed, non-shrink grout containing mineral aggregate meeting the following data requirements.

Compressive strength at plastic consistency, psi

3 days	6,000
7 days	7,000
28 days	8,500

- H. Fire Barrier Assembly - Designed for indicated or required dynamic structural movement without material degradation or fatigue. Tested in maximum joint width conditions with a field splice as a component of the expansion joint cover in accordance with ASTM E-119 at full rated period by a nationally recognized testing and inspecting organization. Supply Fire Barrier as governed by joint opening and fire rating.

2.03 Fabrication

- A. Aluminum extrusions to be shipped in standard 10ft. lengths and shall be cut to length on jobsite where required. Extrusions shall be miter cut in the field to conform to directional changes unless otherwise contracted with expansion joint manufacturer.
- B. Anchor holes shall be shop drilled in accordance with manufacturer's drawings.



Erie Metal Specialties, Inc.  
13311 Main Road  
Akron, NY 14001  
Phone: 716-542-3991  
Fax: 716-542-3996  
E-mail: [sales@eriemetal.com](mailto:sales@eriemetal.com)  
Website: [www.eriemetal.com](http://www.eriemetal.com)

- C. Elastomeric seals shall be shipped in the longest practical continuous length in manufacturer's standard shipping carton.
- D. Fire Barriers - Ship manufacturer's standard assembly for the required hourly rating. Assemblies shall be miter cut in the field to accommodate changes in direction.

#### 2.04 Finishes

- A. Aluminum extrusions shall be supplied in standard mill finish.
- B. Elastomeric seal shall be supplied in standard color offering: black, beige or gray. Optional custom colors available. Select from manufacturers standard color offering.
- C. Surfaces of aluminum extrusions that will be in direct contact with concrete where moisture is present shall receive manufacturer's recommended coating.

### **PART 3 - EXECUTION**

#### 3.01 Installation

- A. Protect all expansion joint component parts from damage during installation of flooring materials, work in adjacent areas and thereafter until completion of structure.
- B. Expansion joint systems shall be installed in strict accordance with the manufacturer's typical details and instructions along with the advice of their qualified representative.
- C. Expansion joint systems shall be set to the proper width for the ambient temperature at the time of installation. This information is indicated in the contract plans.

#### 3.02 Clean and Protect

- A. Protect system and its components during construction. After work is complete in adjacent areas clean exposed surfaces with a suitable cleaner that will not harm or attack the elastomeric material or metal finishes.

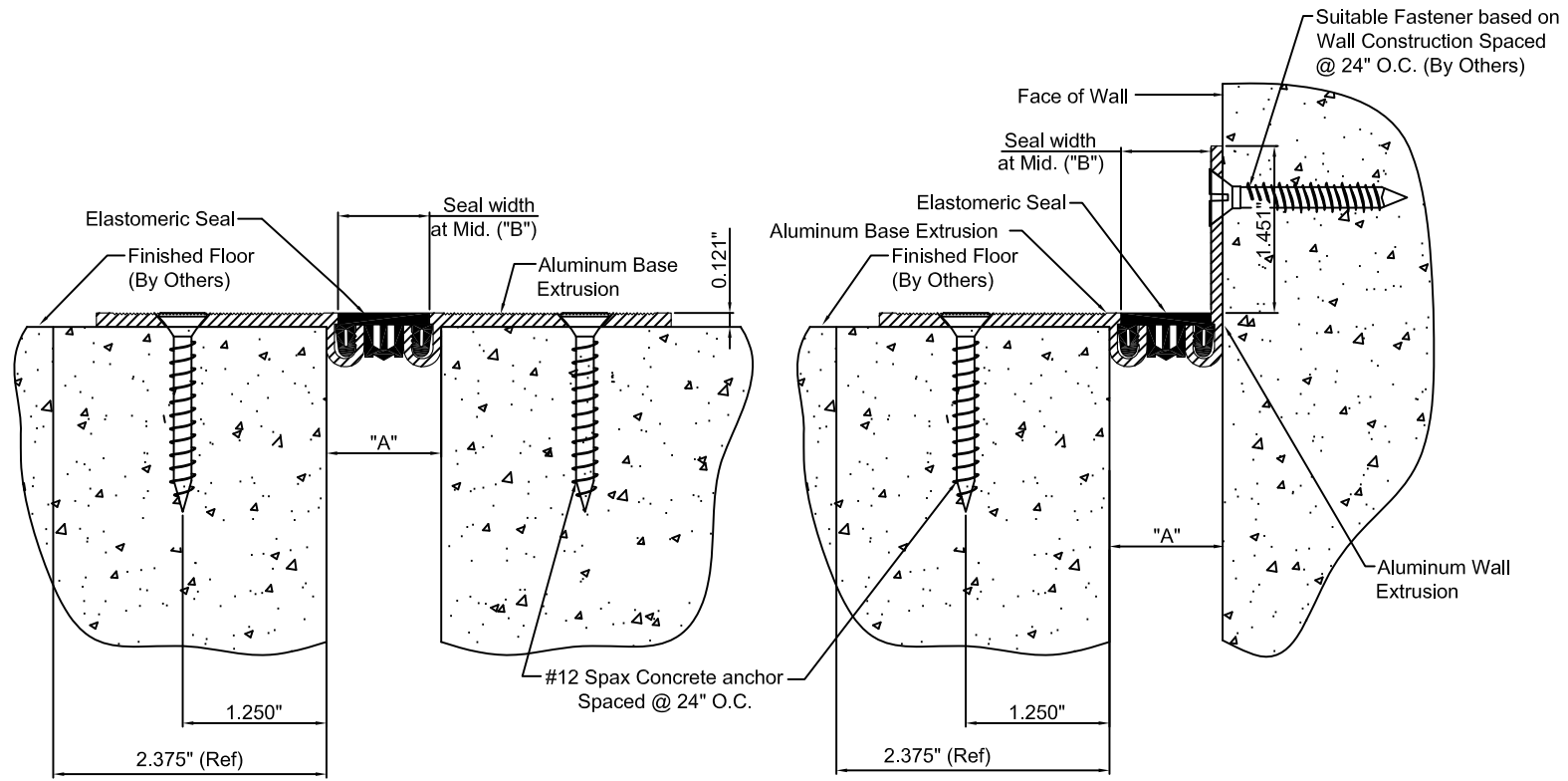

**ELCFT-100 DETAIL**  
FLOOR TO FLOOR CONDITION

**ELCFT-100W DETAIL**  
FLOOR TO WALL CONDITION

( ) - Denotes Millimeters

Dimension Chart					
MODEL	"A" @ Min.	"A" @ Mid.	"A" @ Max.	Total Movement	"B"
ELCFT-100/100W	.75"(19)	1.00"(25)	1.25"(32)	.50"(13)	.781"(20)

NO.	Description	Date	By
<p>The information contained herein is the proprietary property of ERIE METAL SPECIALTIES, INC. No portion of it may be reproduced by any means or used in any form except for the purpose for which it was intended. All rights of design and invention are hereby reserved.</p>			



13311 Main Road • Akron • New York • 14001  
 Phone: (716) 542-3991 • Fax: (716) 542-3996 • E-mail: sales@eriemetal.com

**PROJECT:**

---

**TITLE:**

Detailed by: BAF	Date: 10/21/17
Checked By: SLP	Date: 10/21/17
Scale: NTS	EMS Job #:
Sheet No.: 1 of 1	Drawing No.:

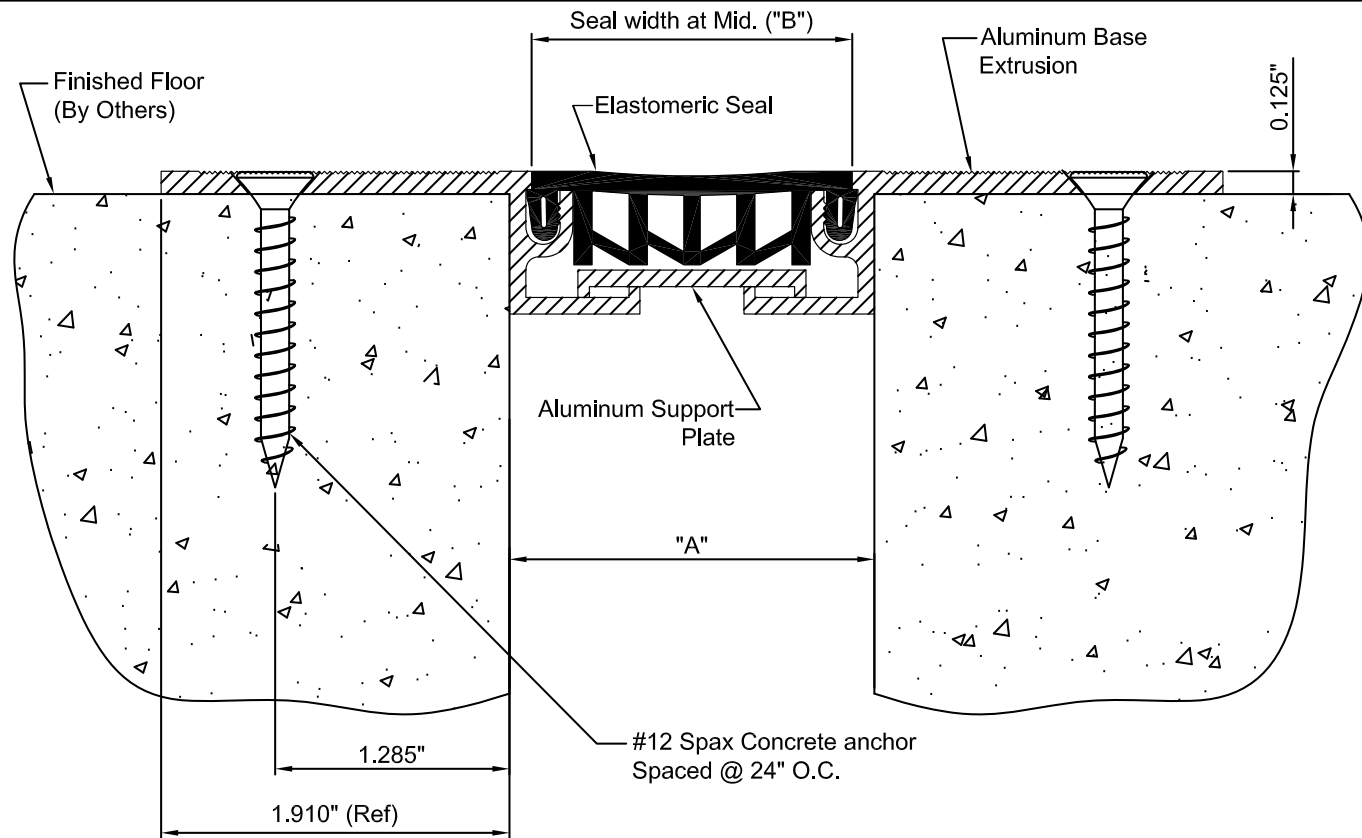

( ) - Denotes Millimeters

Dimension Chart					
MODEL	"A" @ Min.	"A" @ Mid.	"A" @ Max.	Total Movement	"B"
ELCFT-200	1.50"(38)	2.00"(51)	2.50"(64)	1.00"(25)	1.781"(45)

NO.			

The information contained herein is the proprietary property of ERIE METAL SPECIALTIES, INC. No portion of it may be reproduced by any means or used in any form except for the purpose for which it was intended. All rights of design and invention are hereby reserved.



13311 Main Road • Akron • New York • 14001  
 Phone: (716) 542-3991 • Fax: (716) 542-3996 • E-mail: sales@eriemetal.com

PROJECT:

TITLE:

Detailed by: BAF	Date: 10/21/17
Checked By: SLP	Date: 10/21/17
Scale: NTS	EMS Job #:
Sheet No.: 1 of 1	Drawing No.:



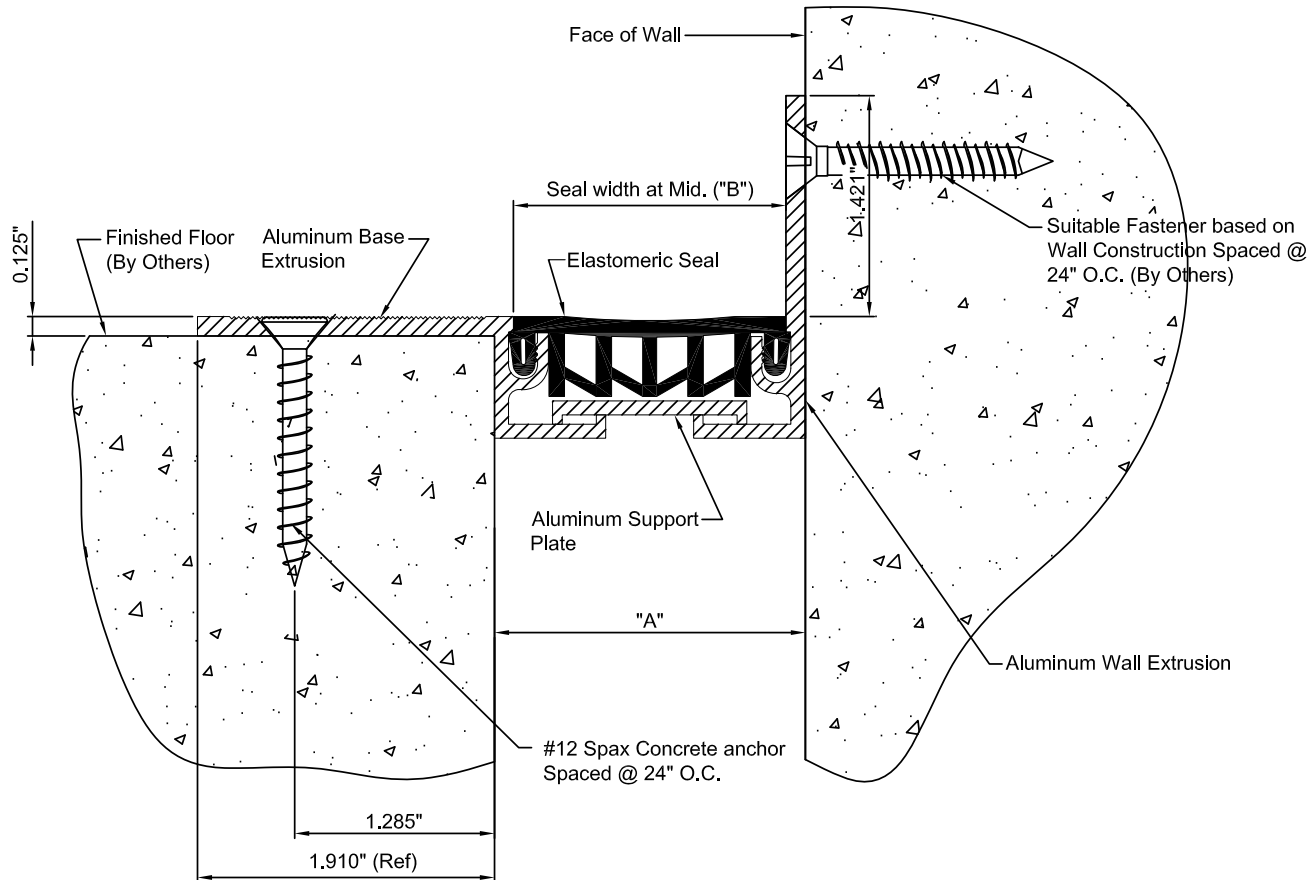

( ) - Denotes Millimeters

Dimension Chart					
MODEL	"A" @ Min.	"A" @ Mid.	"A" @ Max.	Total Movement	"B"
ELCFT-200W	1.50"(38)	2.00"(51)	2.50"(64)	1.00"(25)	1.781"(45)

NO.			

The information contained herein is the proprietary property of ERIE METAL SPECIALTIES, INC. No portion of it may be reproduced by any means or used in any form except for the purpose for which it was intended. All rights of design and invention are hereby reserved.



13311 Main Road • Akron • New York • 14001  
 Phone: (716) 542-3991 • Fax: (716) 542-3996 • E-mail: sales@eriemetal.com

PROJECT:

TITLE:

Detailed by: BAF	Date: 10/21/17
Checked By: SLP	Date: 10/21/17
Scale: NTS	EMS Job #:
Sheet No.: 1 of 1	Drawing No.: