



SUBSTITUTION REQUEST

(After the Bidding/Negotiating Phase)

Project: _____ Substitution Request Number: _____

 From: _____
 To: _____ Date: _____

 A/E Project Number: _____
 Re: _____ Contract For: _____

Specification Title: _____ Description: _____
 Section: _____ Page: _____ Article/Paragraph: _____

Proposed Substitution: _____
 Manufacturer: _____ Phone: _____
 Address: _____
 Trade Name: _____ Model No.: _____
 Installer: _____ Phone: _____
 Address: _____

History: New product 1-4 years old 5-10 years old More than 10 years old

Differences between proposed substitution and specified product: _____

Point-by-point comparative data attached — REQUIRED BY A/E

Reason for not providing specified item: _____

Similar Installation:

Project: _____ Architect: _____
 Address: _____ Owner: _____
 _____ Date Installed: _____

Proposed substitution affects other parts of Work: No Yes; explain _____

Savings to Owner for accepting substitution: _____ (\$ _____).

Proposed substitution changes Contract Time: No Yes [Add] [Deduct] _____ days.

Supporting Data Attached: Drawings Product Data Samples Tests Reports _____

SUBSTITUTION REQUEST

(After the Bidding/Negotiating Phase — Continued)

The Undersigned certifies:

- Proposed substitution has been fully investigated and determined to be equal or superior in all respects to specified product.
 - Same warranty will be furnished for proposed substitution as for specified product.
 - Same maintenance service and source of replacement parts, as applicable, is available.
 - Proposed substitution will have no adverse effect on other trades and will not affect or delay progress schedule.
 - Cost data as stated above is complete. Claims for additional costs related to accepted substitution which may subsequently become apparent are to be waived.
 - Proposed substitution does not affect dimensions and functional clearances.
 - Payment will be made for changes to building design, including A/E design, detailing, and construction costs caused by the substitution.
 - Coordination, installation, and changes in the Work as necessary for accepted substitution will be complete in all respects.
-

Submitted by: _____

Signed by: _____

Firm: _____

Address: _____

Telephone: _____

Attachments:

A/E's REVIEW AND ACTION

- Substitution approved - Make submittals in accordance with Specification Section 01 25 00 Substitution Procedures.
- Substitution approved as noted - Make submittals in accordance with Specification Section 01 25 00 Substitution Procedures.
- Substitution rejected - Use specified materials.
- Substitution Request received too late - Use specified materials.

Signed by: _____ Date: _____

Additional Comments: Contractor Subcontractor Supplier Manufacturer A/E
 Other:

ELCA Series Ceiling System

This Elastomeric Acoustical Ceiling System limits the sight line of the expansion joint by using an aluminum channel that attaches to the grid system above the sight line. The finished Santoprene seal comes in four colors to match your surrounding substrate and finish material.

FEATURES

ACOUSTIC CEILING Fully integrated with suspended ceiling grid system.

COMPLEMENTARY SEAL COLORS Available in four elastomeric seal color options: beige, white, gray or black.

CONTINUOUS SIGHT LINE This system can be used on walls, ceilings and corners to provide seamless and continuous aesthetics.

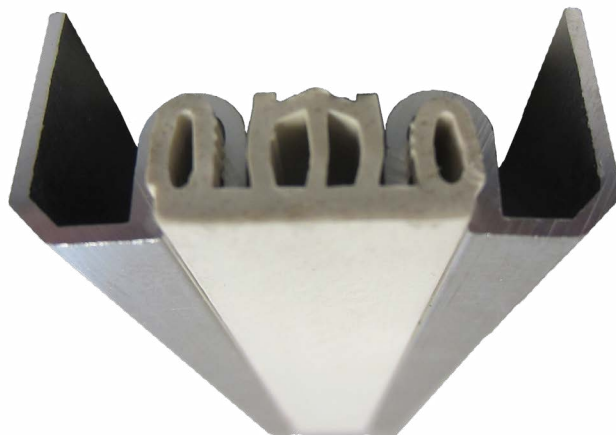

DETAILS

MATERIAL 6063-T6 Aluminum with Rubber Seal

FINISH Mill

MOVEMENT

- Thermal: Horizontal

MOUNTING Flush - Suspended

JOINT SIZE 1 inch to 2 inches

SEAL LENGTH Continuous

APPLICATION Interior

INSTALLATION Ceiling

OPTIONS Seal Color

SEAL COLORS

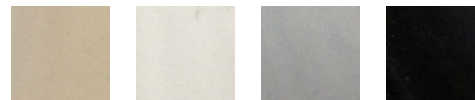

Beige

White

Gray

Black

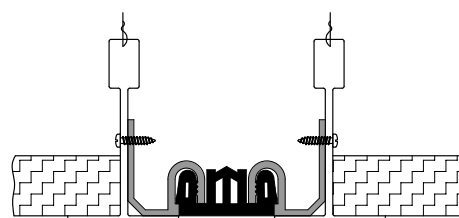

Ceiling-to-Ceiling

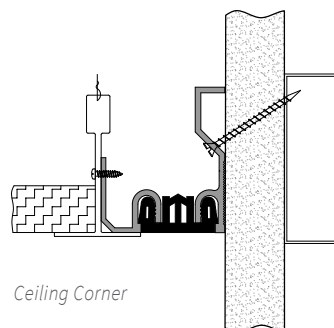

Ceiling Corner

MODELS

MODEL	INSTALLATION	JOINT SIZE AT MEAN T°F	SYSTEM WIDTH	TOTAL MOVEMENT
ELCA-100	Ceiling-to-Ceiling	1" (25mm)	1" (25mm)	0.5" (13mm)
ELCA-100W	Ceiling Corner	1" (25mm)	1" (25mm)	0.5" (13mm)
ELCA-200	Ceiling-to-Ceiling	2" (51mm)	2" (51mm)	1" (25mm)
ELCA-200W	Ceiling Corner	2" (51mm)	2" (51mm)	1" (25mm)



Erie Metal Specialties, Inc.
13311 Main Road
Akron, NY 14001

Phone: 716-542-3991
Website: www.eriametal.com
E-Mail: sales@eriametal.com



Erie Metal Specialties, Inc.
13311 Main Road
Akron, NY 14001

Phone: 716-542-3991
Website: www.eriemetal.com
E-Mail: sales@eriemetal.com

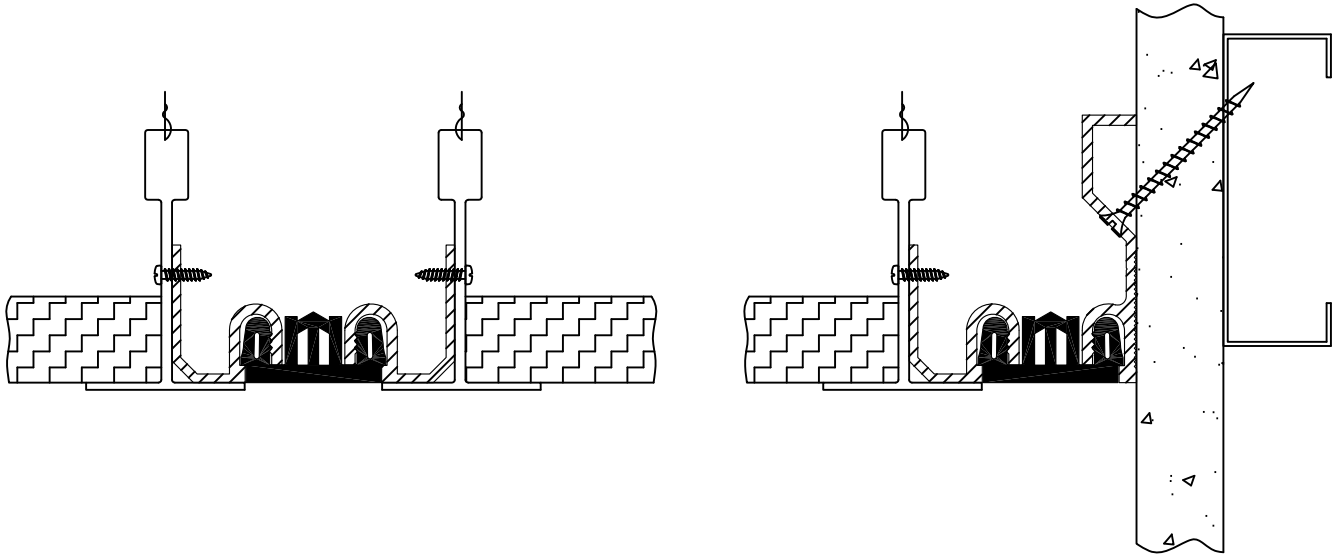

Seal Wall - Standard Series Model(s) "ELCA-100/200/300" & "ELCA-100W/200W/300W" Vertical Expansion Control Systems

The following installation procedure is very important and must be fully understood prior to beginning any work. To ensure proper installation and performance of expansion joint system the following actions must be completed by the installing contractor. Failure to do so will affect product warranty.

- 1) Carefully read and understand installation procedure. Contact Technical Service Department for product assistance.
- 2) Inspect all shipments and materials for missing or damaged components and hardware. Contact Customer Service with order number and invoice for prompt assistance.
- 3) Inspect substrate or adjacent construction for acceptance before beginning work. Report unacceptable construction to the project manager for scheduled repair work.

PN: 28048A

Standard Components

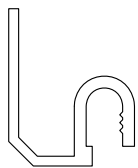

Ceiling Extrusion
Part Number-27426

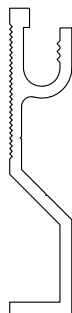

Corner Wall Extrusion
Part Number-27427

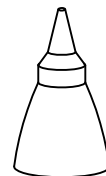

**SI 750 Adhesive
Part Number - 27514

**Optional components for splice procedures. Place order for required quantities.

Components shown below vary in size depending on model of system

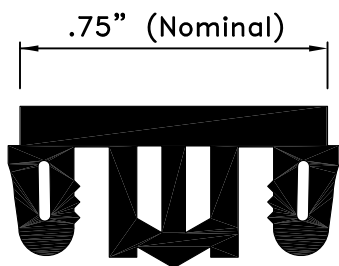

ELCA-100
ELCA-100W

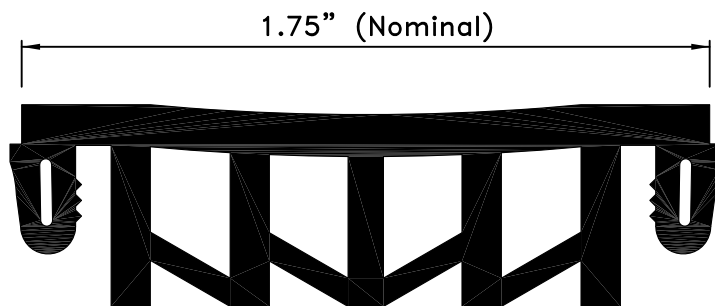

ELCA-200
ELCA-200W

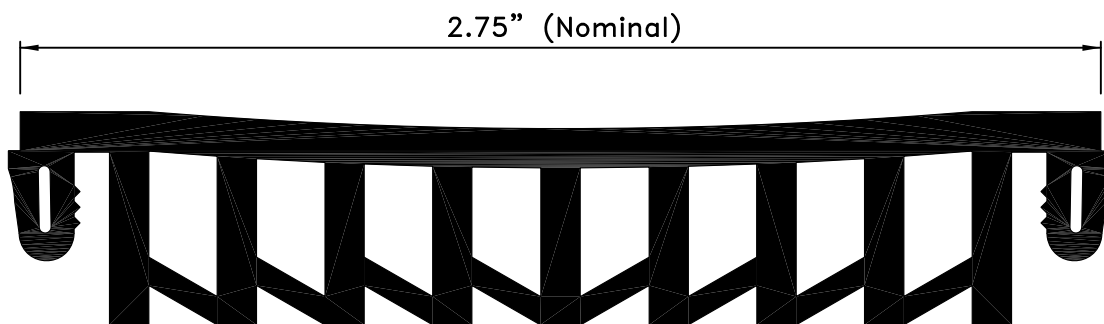

ELCA-300
ELCA-300W

Seal Part Number				
Model	Black Seal	White Seal	Grey Seal	Beige Seal
ELCA-100	28001	28002	28003	28004
ELCA-200	28005	28006	28007	28008
ELCA-300	28031	28032	28033	28034

Installation Procedure

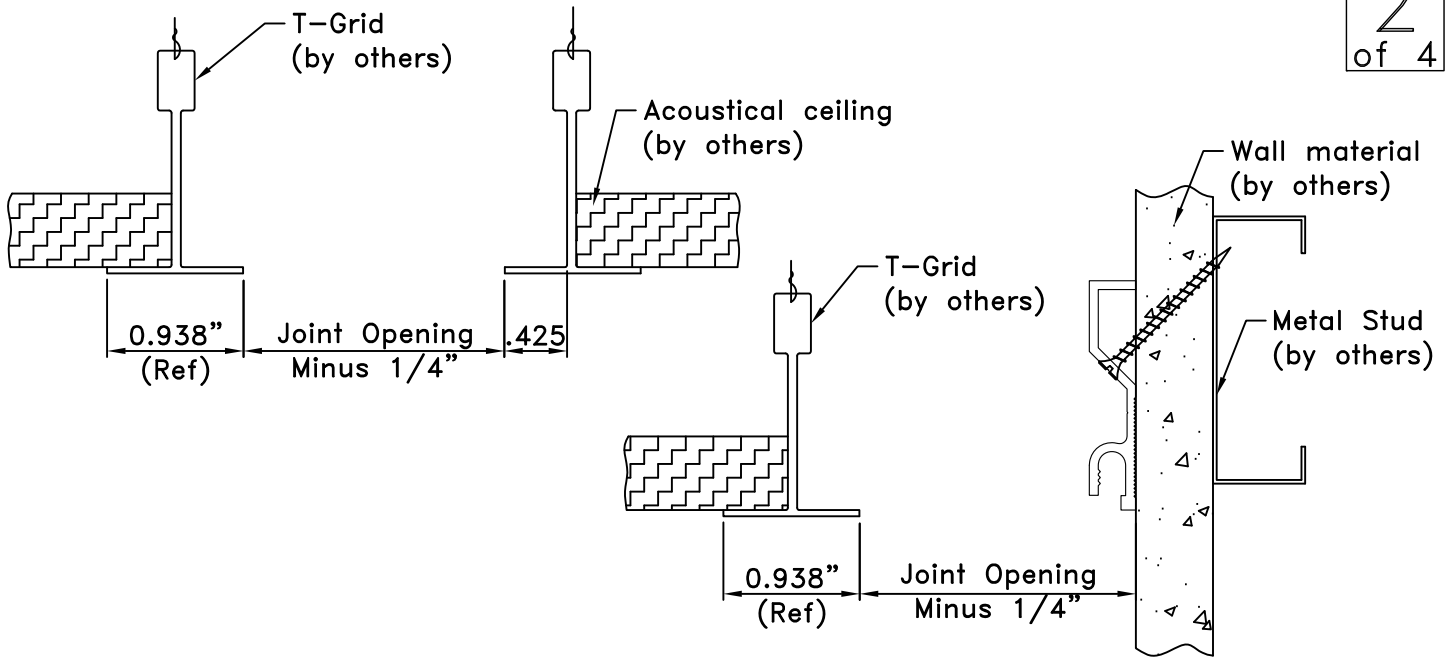

1

Prior to beginning work, installer shall inspect for proper ceiling construction. Verify joint opening to match expansion control system requirements.

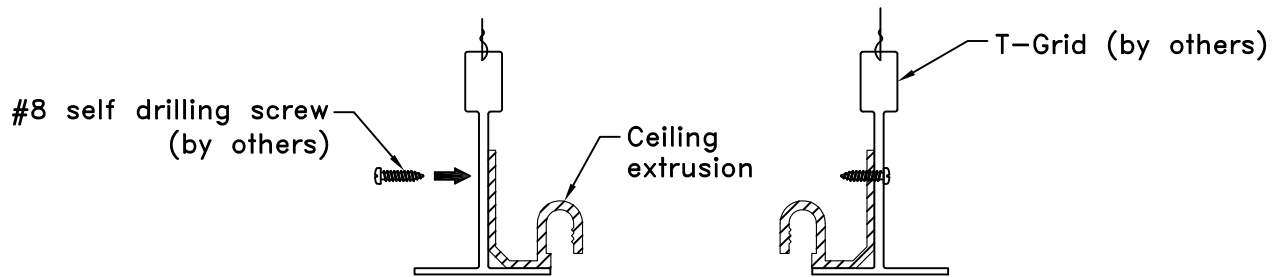

2

Prior to fastening the ceiling extrusion to the "T" grid, remove ceiling tiles on both sides of the joint location. Once ceiling tiles have been removed, the contractor can fasten the aluminum extrusion to the "T" grid using at least #8 self drilling screws (by others) space at 24" O.C.

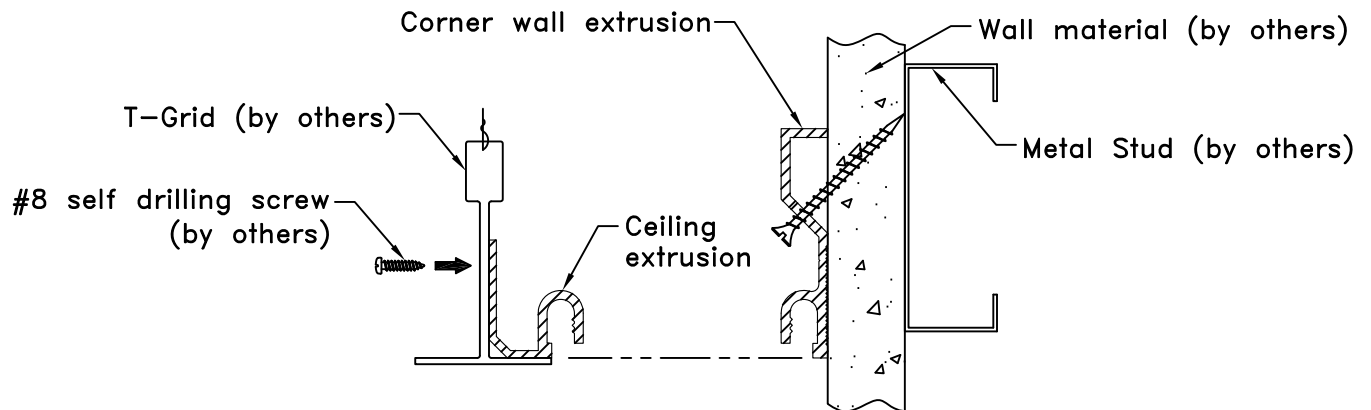

2A

Place aluminum corner wall extrusion on edge of opening as shown. Drill through extrusion, drywall and into stud. Fasten with drywall screws (by others) spaced at 24" O.C. max, starting 6" from ends. Prior to fastening the ceiling extrusion to the "T" grid, remove ceiling tiles on both sides of the joint location. Once ceiling tiles have been removed, the contractor can fasten the aluminum extrusion to the "T" grid using at least #8 self drilling screws (by others) space at 24" O.C.

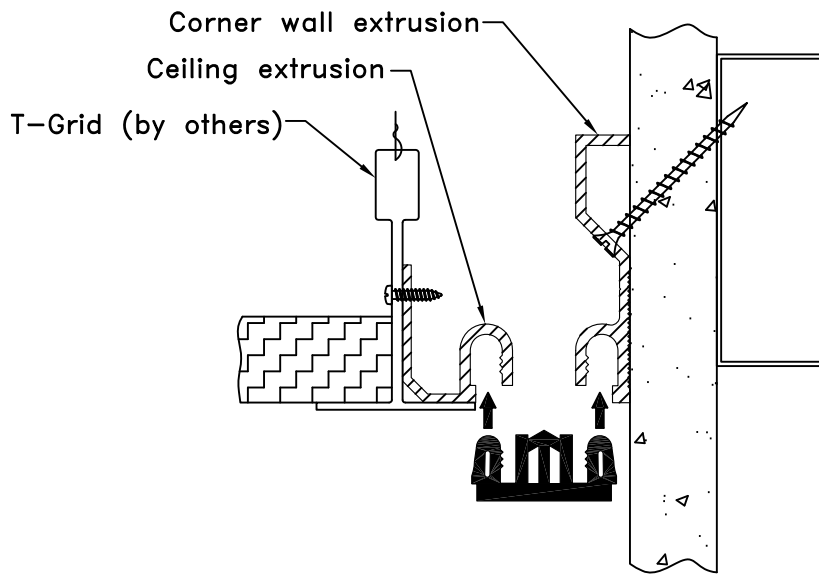
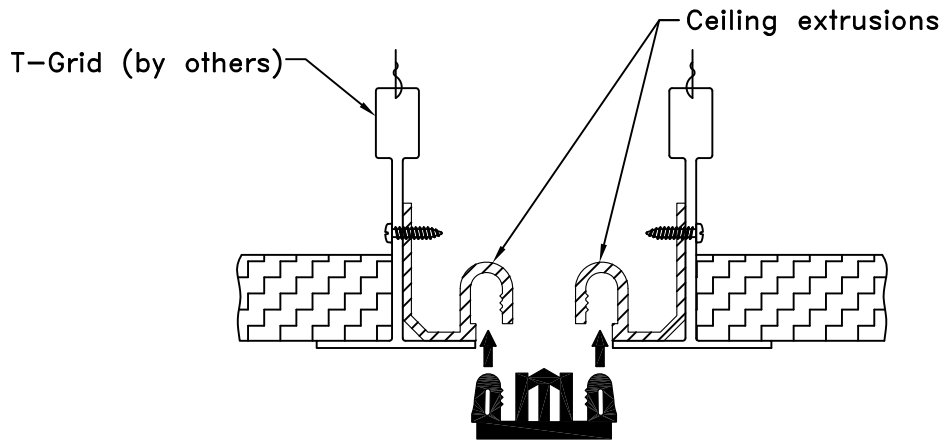

3

Squeeze or slide elastomeric seal into the cavities of the aluminum extrusion.

Suggested Field Splice Procedure

1. Cut ends of seal with a sharp knife and miter box to the desired angle. Insure that cuts are clean and straight.
2. Clean ends of seal with a solvent.
3. Apply SI 750 Adhesive to one of the two seal ends to be bonded.
4. Apply pressure bringing the two surfaces into tight contact immediately after adhesive is applied. Hold in place for one to two minutes for initial bond.
5. Re-Check quality of all splices/miters and apply adhesive as required.
7. It is usually recommended to allow 15 minutes prior to installing seal. To achieve proper working strength care shall be exercised as a result that it takes 24 hours for adhesive to fully cure.

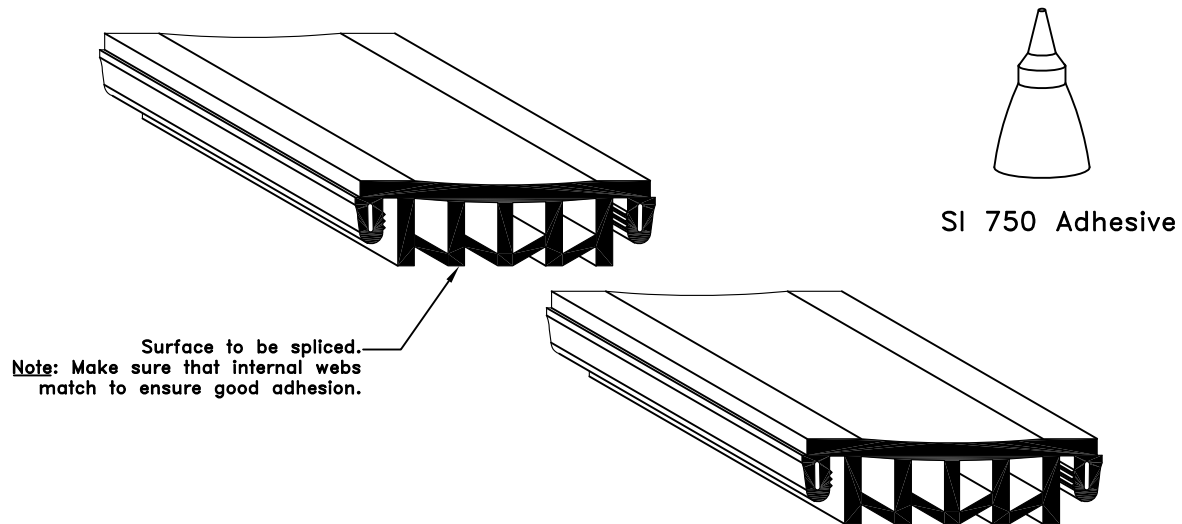



Erie Metal Specialties, Inc.
13311 Main Road
Akron, NY 14001
Phone: 716-542-3991
Fax: 716-542-3996
E-mail: sales@eriemetal.com
Website: www.eriemetal.com

SPECIFICATION

Section 07 95 13

Erie Metal Specialties, Interior Architectural Systems

Model(s) ELCD, ELCE, ELCA, ELCH Series for Wall, Soffit and Ceiling

Interior Seismic Expansion Control System

PART 1 – GENERAL

1.01 Work Included

- A. The work shall consist of furnishing and installing expansion joints in accordance with the details shown on the plans and the requirements of the specifications. The joints are proprietary designs utilizing extruded elastomeric seals and aluminum profiles.

- B. Related Work
 - Miscellaneous and ornamental metals
 - Sealants and caulking
 - Interior Finishes

1.02 Submittals

- A. Template Drawings - Submit typical expansion joint cross-section(s) indicating pertinent dimensioning, general construction, component connections, and anchorage methods.

1.03 Product Delivery, Storage and Handling

- A. Deliver products in each manufacturer's original, intact, labeled containers and store under cover in a dry location until installed. Store off the ground, protect from weather and construction activities.

1.04 Acceptable Manufacturer

- A. All joints shall be supplied by; Erie Metal Specialties, Inc. • 13311 Main Road • Akron • New York • 14001 • Phone (716) 542-3991 • Fax (716) 542-3996 • sales@eriemetal.com • www.eriemetal.com .
- B. Alternate manufacturers and their products will be considered, provided they meet the design concept and are produced of materials that are equal to or superior to those called for in the base product specification.
- C. Any proposed alternate systems must be submitted and receive approval 21 days prior to the bid. All post bid submittals will not be considered. This submission shall be in accordance with MATERIALS AND SUBSTITUTIONS.



Erie Metal Specialties, Inc.
13311 Main Road
Akron, NY 14001
Phone: 716-542-3991
Fax: 716-542-3996
E-mail: sales@eriemetal.com
Website: www.eriemetal.com

- Any manufacturer wishing to submit for prior approval must provide the following:

1. A working 6" sample of the proposed system with a letter describing how system is considered superior to the specified system.
2. A project proposal drawing that illustrates the recommended alternate system installed in the wall or ceiling construction that is specific to the project. Typical catalog cut sections will not be considered.
3. Verifiable list of prior installations showing prior and successful experience with the proposed systems.
4. Any substitution products not adhering to all specification requirements within, will not be considered.

1.05 Quality Assurance

- A. Warranty: The expansion control system's performance shall be warranted for a period of 1 year. Installation shall be in strict accordance with manufacturer's technical specifications, details, installation instructions and general procedures in effect for normal intended usage and suitable applications under specified design movements and loading conditions.
- B. Manufacturer: Shall have a minimum ten (10) years experience specializing in the design and manufacture of Architectural Expansion Control Systems.
- C. Maintenance: The manufacturer shall provide the owner-operator a preventive maintenance guideline for Expansion Control Systems.

PART 2 - PRODUCT

2.01 General

- A. Provide interior wall and ceiling expansion joint system that incorporates specially engineered elastomeric colorable profiles to facilitate multi-directional seismic movement without stress to adjacent components. Design system to be easily installed and surface mounted to traditional drywall construction utilizing drywall screws. Aluminum extrusions shall be designed with mounting flanges exhibiting factory pre-punched holes properly sized and spaced to receive joint compound.

For walls, soffits and ceilings furnish Erie Metal Specialties, Model "ELCA, ELCD, ELCE, ELCH" Expansion Control System as indicated on drawings.



Erie Metal Specialties, Inc.
13311 Main Road
Akron, NY 14001
Phone: 716-542-3991
Fax: 716-542-3996
E-mail: sales@eriemetal.com
Website: www.eriemetal.com

2.02 Components and Materials

- A. Aluminum Extrusions - Material to conform to properties of ASTM B221, alloy 6063-T5. Profile shall be lightweight and capable of accommodating various wall and ceiling conditions. Design profile with semi-closed extrusion cavity and features that will provide a mechanical lock for the Elastomeric Seal.
- B. Aluminum Shapes - Material to conform to ASTM B209, alloy 6061-T6 or 5005-H34.
- C. Elastomeric Seals - Material shall be a flexible extruded Santoprene or manufacturer's alternate material exhibiting a shore A hardness of 64 +/-5 with U.V. stabilizer. The seal shall be a multi-cellular profile with side lugs that mechanically snap lock into a corresponding extrusion cavity without assistance from fasteners for a secure fit.
- D. Anchors - Secure aluminum extrusion(s) by utilizing standard drywall screws for gypsum wall board construction. Screws are supplied by others and shall be of proper length to secure aluminum extrusion. Locate screws within solid metal between factory pre-punched flange holes. Anchor spacing shall be 24" c.c. maximum.
- E. Accessories - Provide necessary and related parts required for complete installation.

2.03 Fabrication

- A. Aluminum extrusions shall be supplied in 10 ft. lengths. The contractor shall be responsible for field cutting the extrusion to obtain the proper joint profile. All cutting and mitering of the seal required at directional changes shall be performed by the contractor in a neat and workmanlike manner utilizing manufacturers recommended splice clips and adhesive.
- C. All anchor holes shall be field drilled in accordance with manufacturer's drawings. Spacing shall be a maximum of 24" c.c.

2.04 Finishes

- A. Aluminum extrusions shall be supplied in standard mill finish.
- B. Elastomeric seals shall be supplied in standard colors - Black, beige, and gray. Optional custom colors available

PART 3 - EXECUTION

3.01 Installation

- A. Protect all expansion joint component parts from damage during installation and thereafter until completion of structure.



Erie Metal Specialties, Inc.
13311 Main Road
Akron, NY 14001
Phone: 716-542-3991
Fax: 716-542-3996
E-mail: sales@eriemetal.com
Website: www.eriemetal.com

- B. Expansion joint systems shall be installed in strict accordance with the manufacturer's typical details and instructions along with the advice of their qualified representative.
- C. Contractor shall provide proper and adequate adjacent construction to receive and support the expansion control joint system. The supporting framework (studding) shall be of design to secure all threaded hardware and provide rigidity for the proper installation and function of the joint system.

3.02 Clean and Protect

- A. Protect system and its components during construction. After work is complete in adjacent areas clean exposed surfaces with a suitable cleaner that will not harm or attack the elastomeric material.

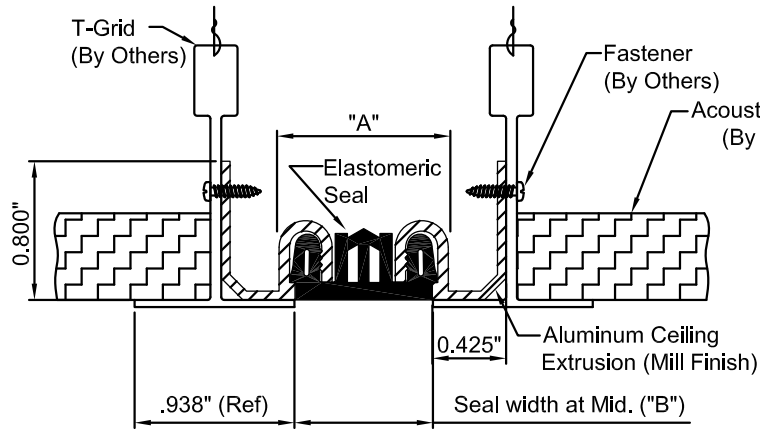

ELCA-100 DETAIL
CEILING TO CEILING CONDITION

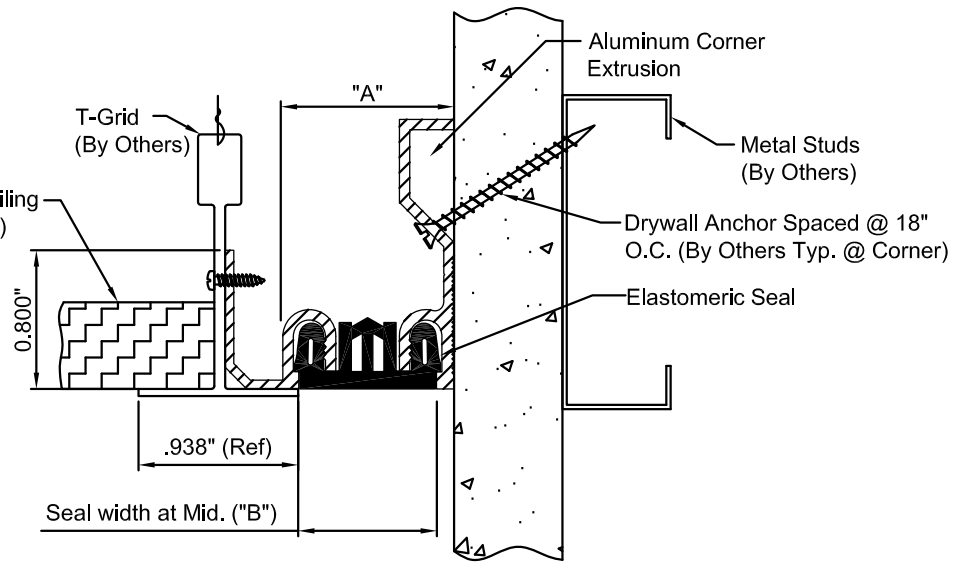

ELCA-100W DETAIL
CEILING TO WALL CONDITION

() - Denotes Millimeters

Dimension Chart					
MODEL	"A" @ Min.	"A" @ Mid.	"A" @ Max.	Total Movement	"B"
ELCA-100/100W	.75"(19)	1.00"(25)	1.25"(32)	.50"(13)	.781"(20)

NO.	Description	Date	By

The information contained herein is the proprietary property of ERIE METAL SPECIALTIES, INC. No portion of it may be reproduced by any means or used in any form except for the purpose for which it was intended. All rights of design and invention are hereby reserved.



13311 Main Road • Akron • New York • 14001
Phone: (716) 542-3991 • Fax: (716) 542-3996 • E-mail: sales@eriemetal.com

PROJECT:

TITLE:

Detailed by: BAF	Date: 10/21/17
Checked By: SLP	Date: 10/21/17
Scale: NTS	EMS Job #:
Sheet No.: 1 of 1	Drawing No.:

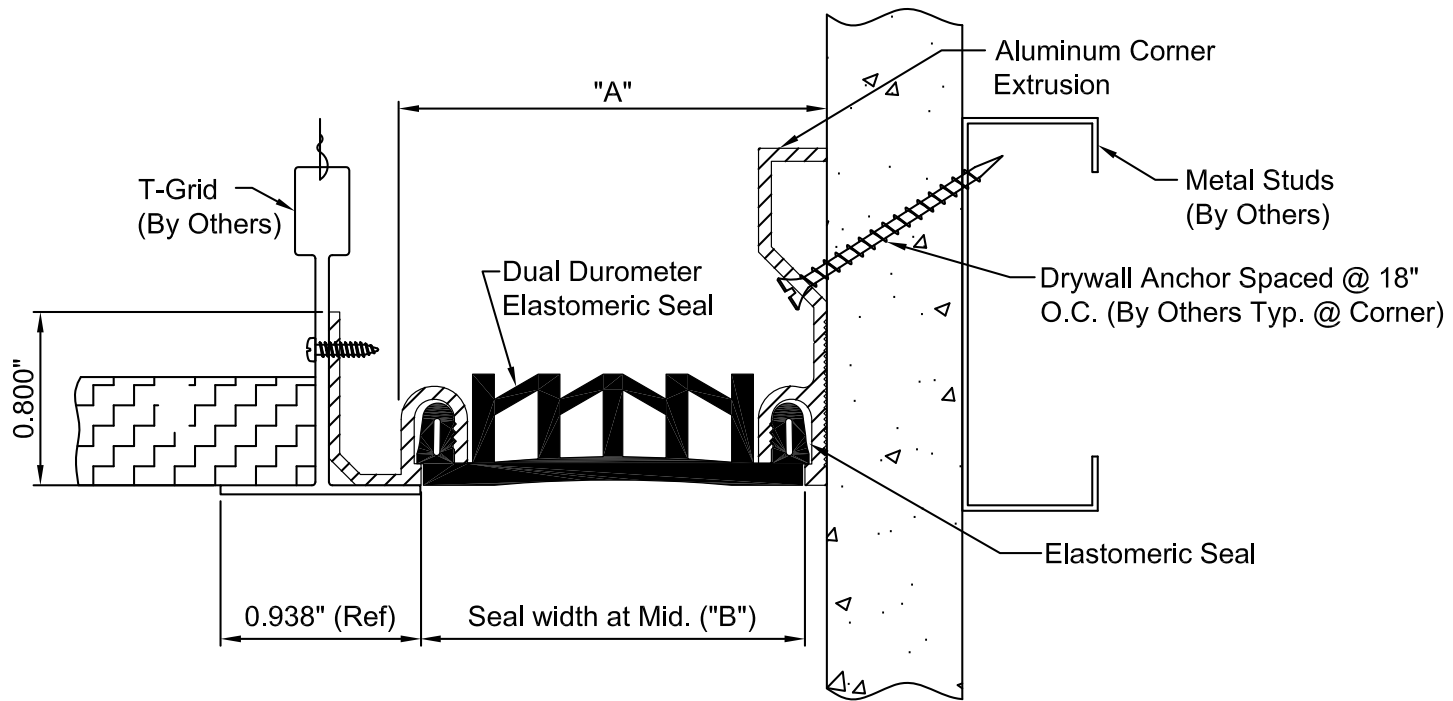

() - Denotes Millimeters

Dimension Chart					
MODEL	"A" @ Min.	"A" @ Mid.	"A" @ Max.	Total Movement	"B"
ELCA-200W	1.50"(38)	2.00"(51)	2.50"(64)	1.00"(25)	1.781"(45)
ELCA-300W	2.25"(57)	3.00"(76)	3.75"(95)	1.50"(38)	2.781"(71)

NO.	Description	Date	By
<p>The information contained herein is the proprietary property of ERIE METAL SPECIALTIES, INC. No portion of it may be reproduced by any means or used in any form except for the purpose for which it was intended. All rights of design and invention are hereby reserved.</p>			



13311 Main Road • Akron • New York • 14001
 Phone: (716) 542-3991 • Fax: (716) 542-3996 • E-mail: sales@eriemetal.com

PROJECT:

TITLE:

Detailed by: BAF	Date: 10/21/17
Checked By: SLP	Date: 10/21/17
Scale: NTS	EMS Job #:
Sheet No.: 1 of 1	Drawing No.:

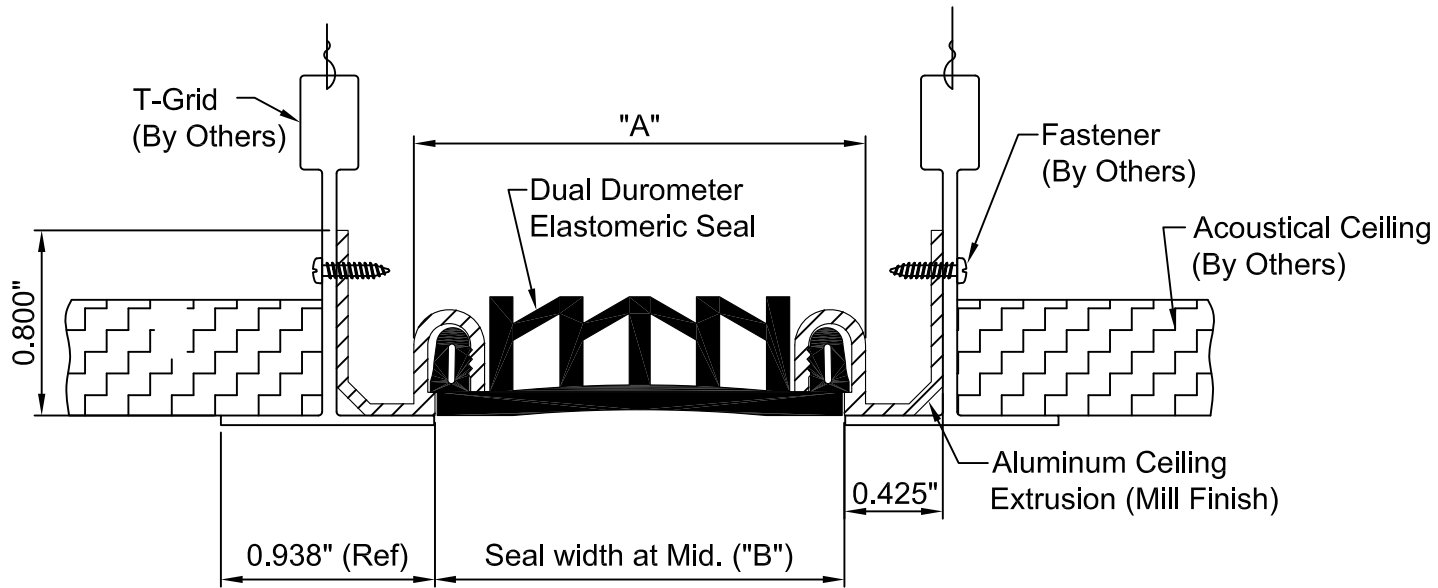

() - Denotes Millimeters

Dimension Chart					
MODEL	"A" @ Min.	"A" @ Mid.	"A" @ Max.	Total Movement	"B"
ELCA-200	1.50"(38)	2.00"(51)	2.50"(64)	1.00"(25)	1.781"(45)
ELCA-300	2.25"(57)	3.00"(76)	3.75"(95)	1.50"(38)	2.781"(71)

NO.	Description	Date	By

The information contained herein is the proprietary property of ERIE METAL SPECIALTIES, INC. No portion of it may be reproduced by any means or used in any form except for the purpose for which it was intended. All rights of design and invention are hereby reserved.



13311 Main Road • Akron • New York • 14001
 Phone: (716) 542-3991 • Fax: (716) 542-3996 • E-mail: sales@eriemetal.com

PROJECT:

TITLE:

Detailed by: BAF	Date: 10/21/17
Checked By: SLP	Date: 10/21/17
Scale: NTS	EMS Job #:
Sheet No.: 1 of 1	Drawing No.: