

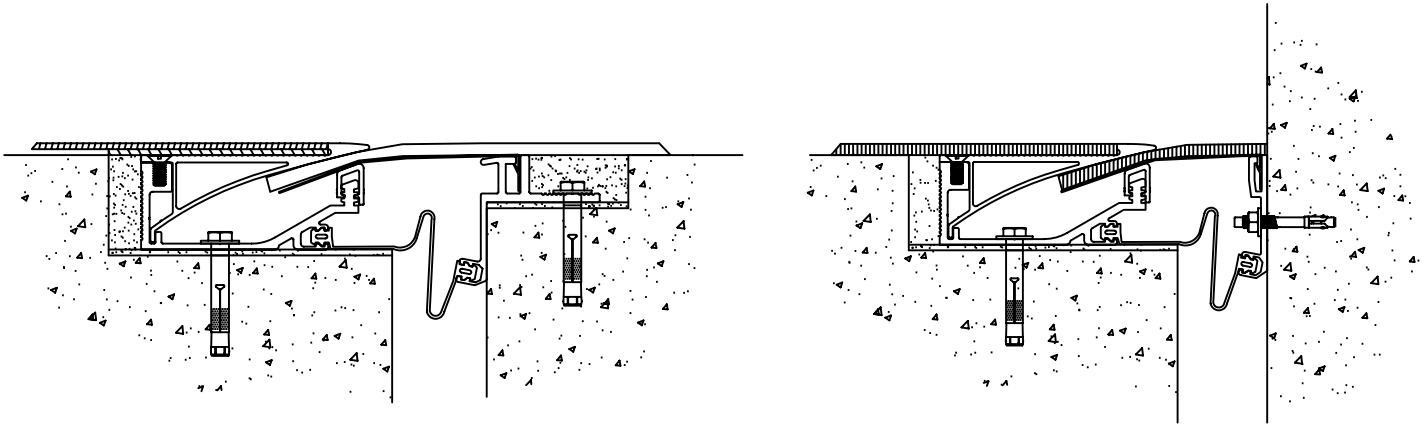

Erie Metal Specialties, Inc.
13311 Main Road
Akron, NY 14001

Phone: 716-542-3991
Website: www.eriemetal.com
E-Mail: sales@eriemetal.com



Flow - Professional Series Model(s) "EFLC" & "EFLC-W" 100-400 Horizontal Expansion Control Systems

The following installation procedure is very important and must be fully understood prior to beginning any work. To ensure proper installation and performance of expansion joint system the following actions must be completed by the installing contractor. Failure to do so will affect product warranty.

- 1) Carefully read and understand installation procedure. Contact Technical Service Department for product assistance.
- 2) Inspect all shipments and materials for missing or damaged components and hardware. Contact Customer Service with order number and invoice for prompt assistance.
- 3) Inspect substrate or adjacent construction for acceptance before beginning work. Report unacceptable construction to the product manager for scheduled repair work.

Standard Components



¼" X ⅝" Csk Flathead Machine Screw PN 5620

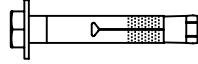

⅜" X 2-¼" Anchor PN 6514

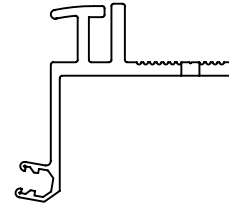

Aluminum Floor Leaf Mount Extrusion PN 18120



Aluminum Adjustable Spring Support PN 17035



Prima-Lub PN 2720

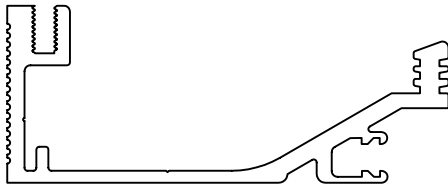

Aluminum Base Support PN 18049

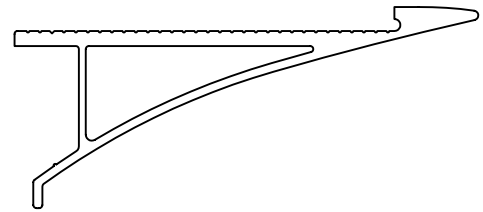

Aluminum Exposed Trim Surface PN 17048

Spring Steel Leaf Spring PN 17009

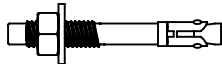

* ¼" X 2-¼" Anchor PN 6581



* Aluminum Wall Mount Leaf Extrusion PN 18044



* Spring Steel Leaf Spring PN 17011

*Components required for corner condition installation.

Components shown below vary in size depending on model of system

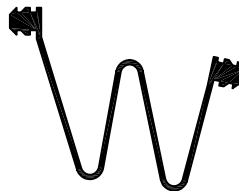

Moisture Barrier PN 1181

Installation Procedure

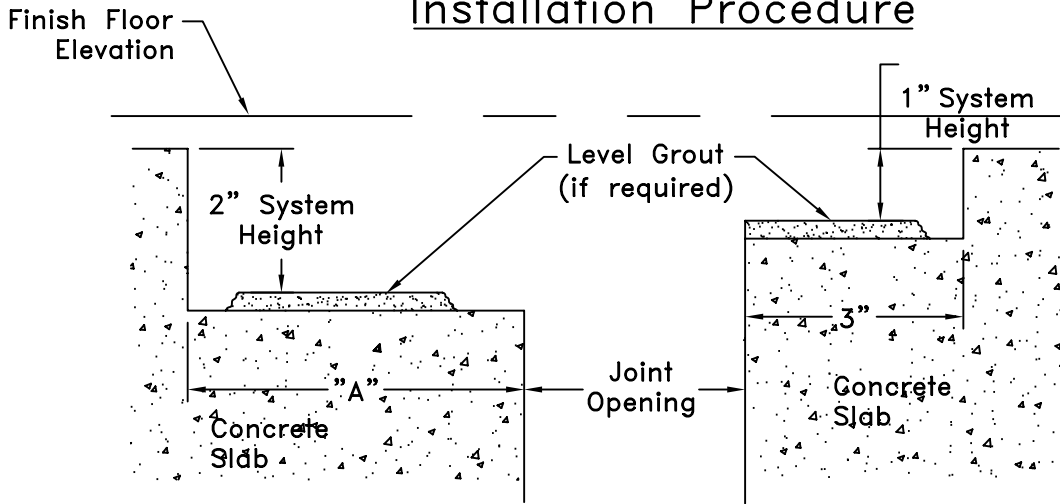

| Dimension Chart | |
|-----------------|-----|
| Model | "A" |
| EFLC-100 | 7" |
| EFLC-200 | 6" |
| EFLC-400 | 4" |

1

Prepare concrete block out for installation of expansion joint. Variations in block out dimensions must be corrected prior to beginning work.

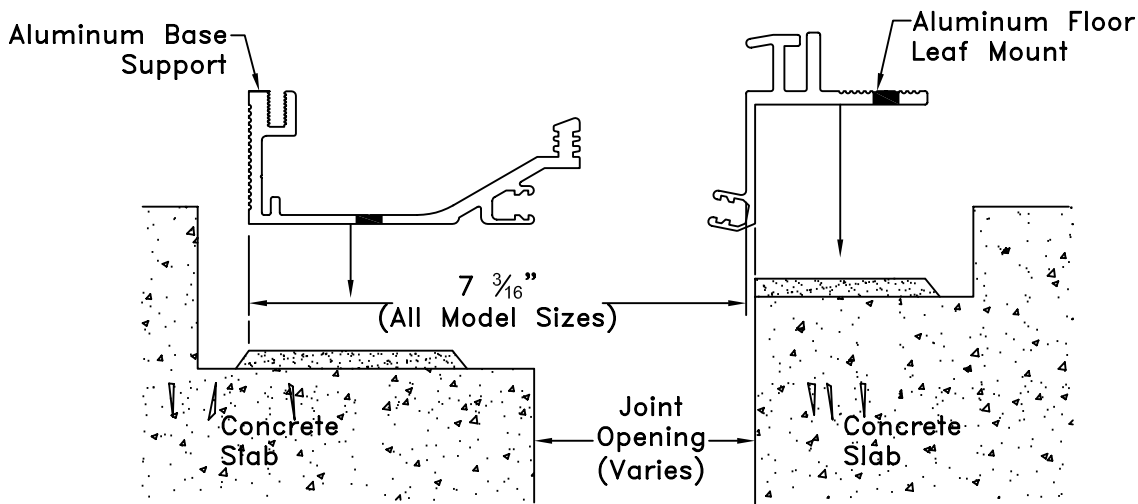

2

Floor – Position Aluminum base support and Aluminum floor leaf mount extrusion on block out as shown. Mark anchor locations.
 Note: Aluminum base support and Aluminum Floor leaf mount must have FULL BEARING on grout or slab.

(Corner Condition)

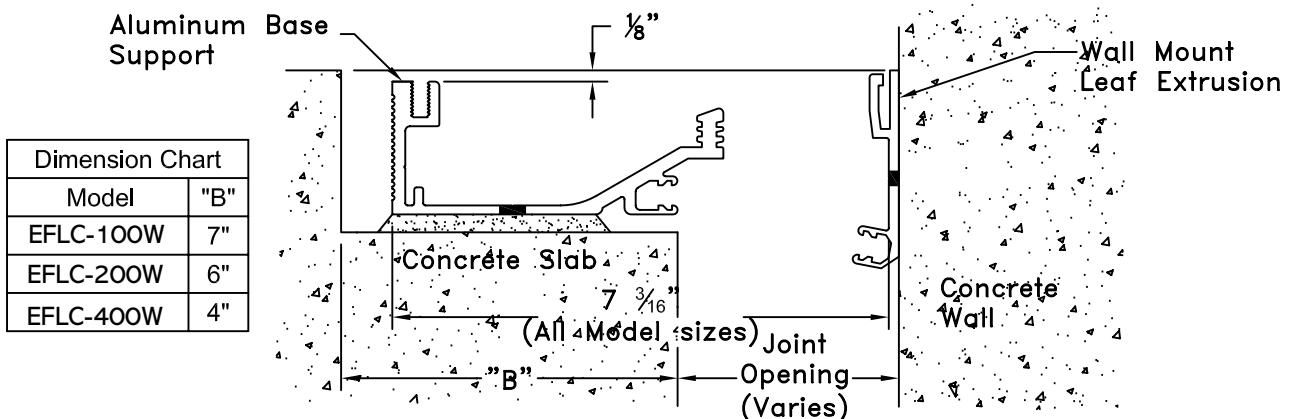

| Dimension Chart | |
|-----------------|-----|
| Model | "B" |
| EFLC-100W | 7" |
| EFLC-200W | 6" |
| EFLC-400W | 4" |

2A

Corner – Align top of wall leaf mount extrusion $\frac{1}{8}$ " above top of Aluminum base member as shown. Mark anchor locations.
 Note: Aluminum base support and Aluminum Floor leaf mount must have FULL BEARING on grout or slab.

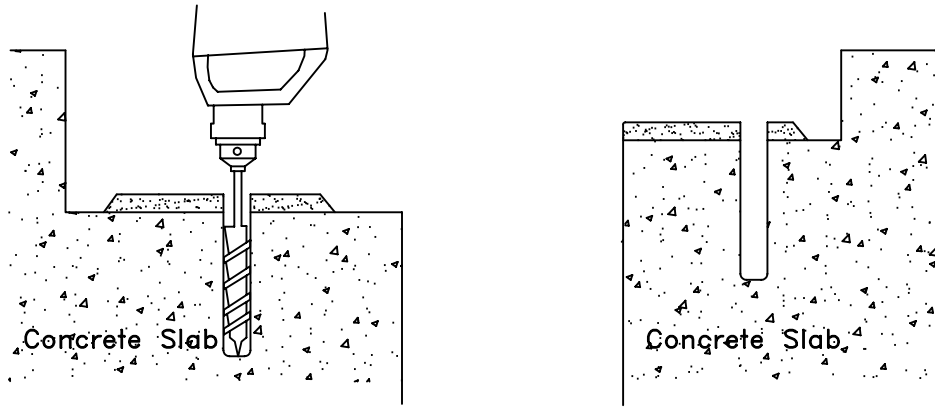

3

Drill holes for $\frac{3}{8}$ " x 2- $\frac{1}{4}$ " anchor to proper depth. Clean out holes.

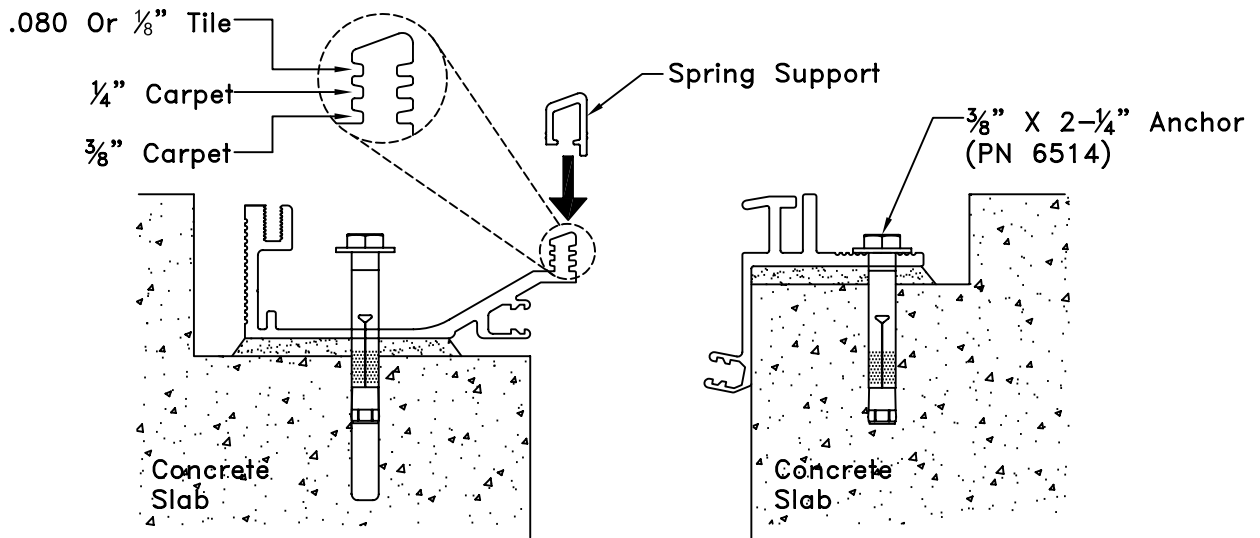

4

Floor – Slide spring support into proper slot of Aluminum base member. Adjust it according to the detail above depending on floor covering being used. Then utilizing manufacturers anchors , mount and secure Aluminum base Extrusion and Aluminum Floor Leaf Mount Extrusion to Concrete Slab.

Corner Condition

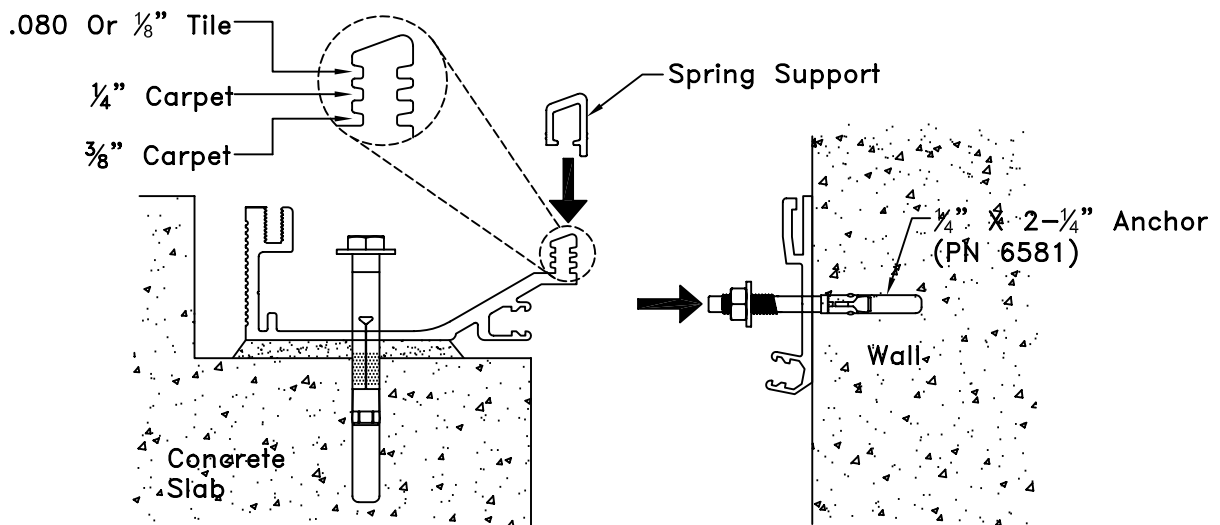

4A

Corner – Slide spring support into proper slot of Aluminum base member. Adjust it according to the detail above depending on floor covering being used. Then utilizing manufacturers anchors , mount and secure Aluminum base Extrusion and Aluminum Floor Leaf Mount Extrusion to Concrete Slab.

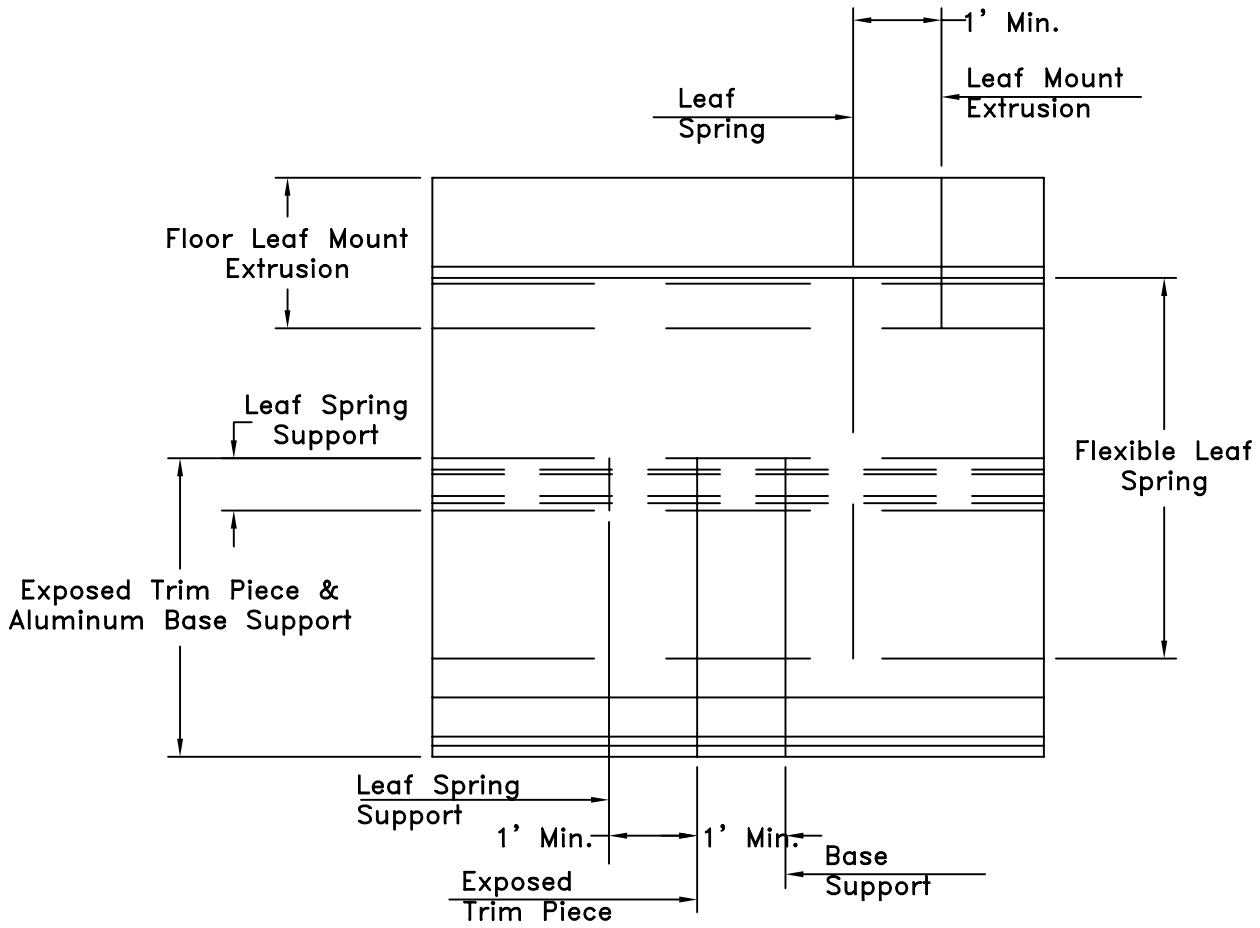

5

Stagger all splices in accordance with detail illustrated above to provide a stronger assembly and durable installation.

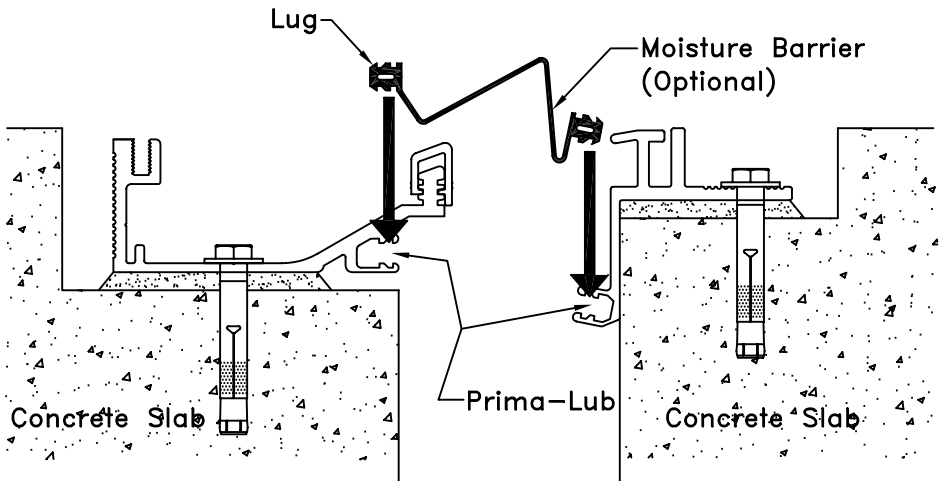

6

(Optional)
Brush apply prima-lub adhesive into extrusion cavity and install moisture barrier exercising care not to damage moisture barrier, ensure full engagement of locking lug.

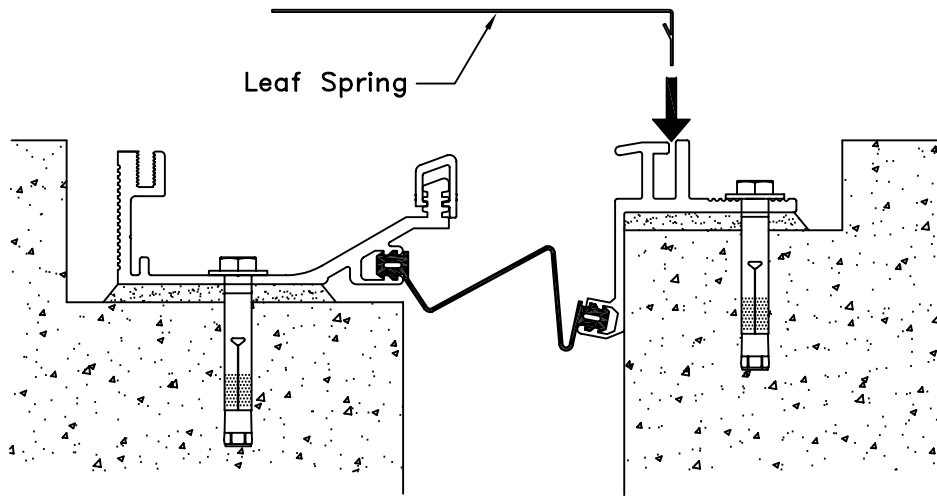

7 Snap leaf spring into leaf mount extrusion. Ensure top surface of leaf mount extrusion is flush with top surface of leaf spring.

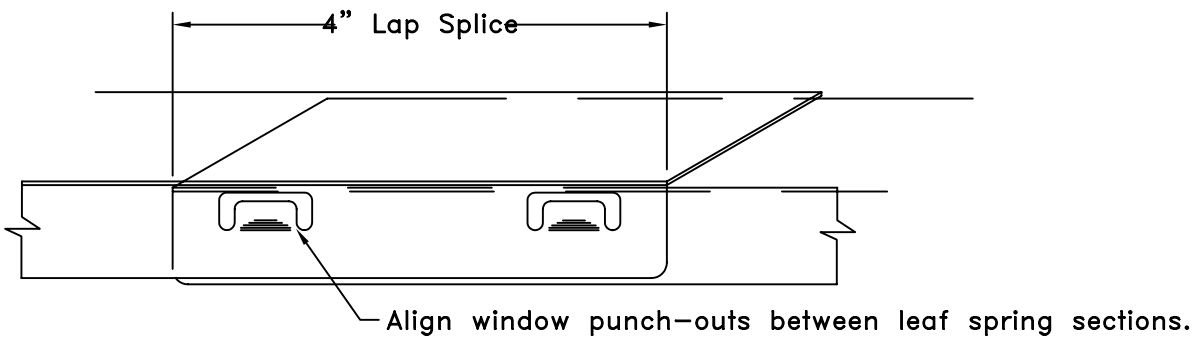

8 Stagger all splices in accordance with detail illustrated above to provide a stronger assembly and durable installation.

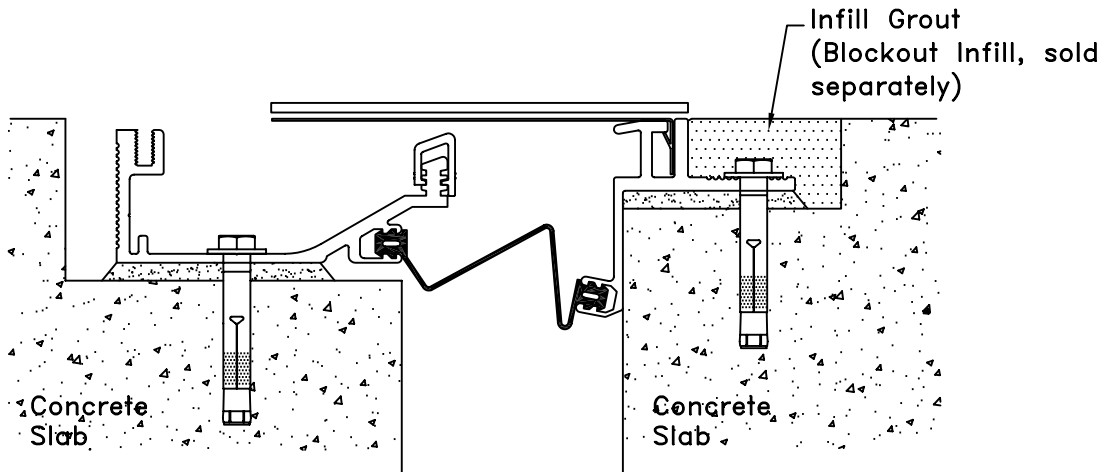

9 Install Grout into blockout on Leaf Spring Side after Leaf Spring and anchors have been installed.
Note: Protect surfaces during placement of blockout infill.

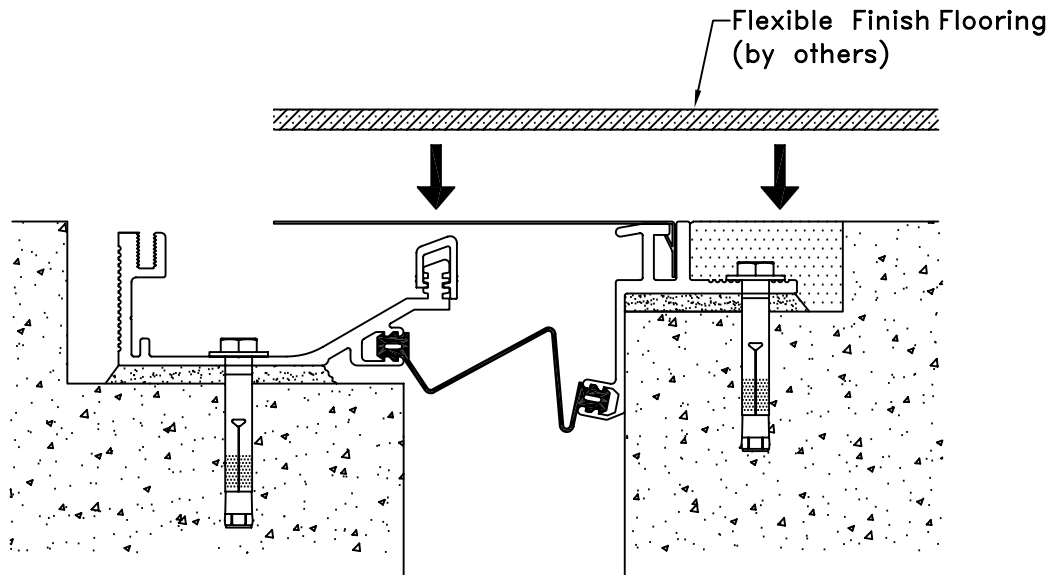

10

Install flooring material on leaf spring side ONLY.

Note: Follow flooring manufacturers application procedures for proper installation of flooring material. Prepare leaf spring for carpet tape or adhesive as recommended by flooring manufacturer.

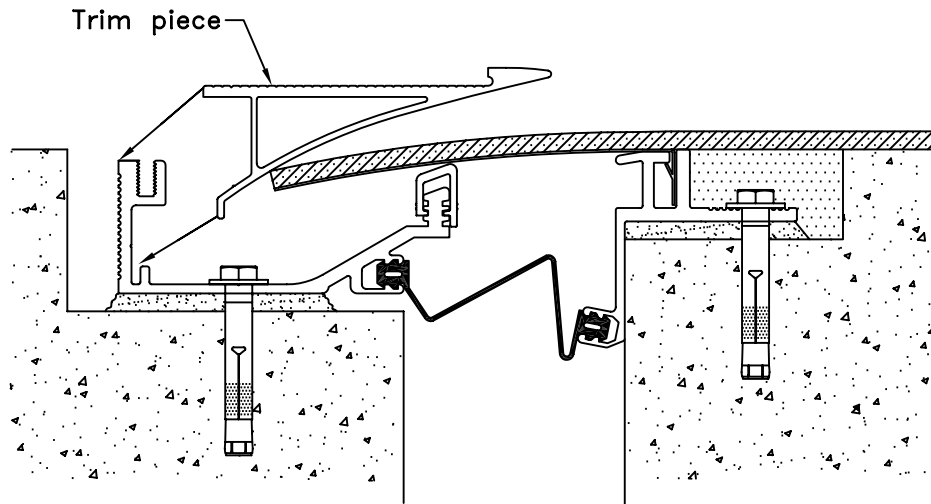

11

Slide trim piece into place, pushing down on the leaf spring as shown.

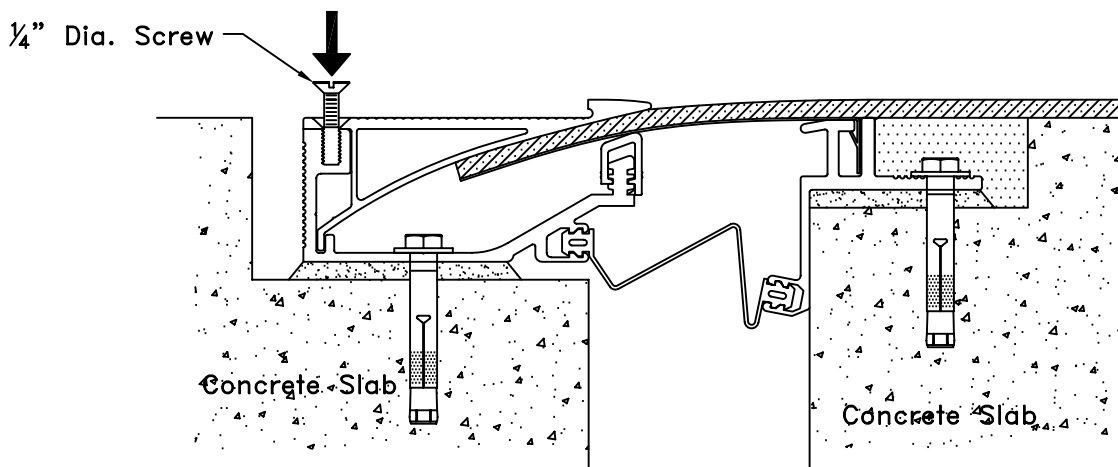

12

Maintain pressure on trim piece. Fasten trim piece to base extrusion utilizing $\frac{1}{4}$ " dia csk machine screw until flush with surface.

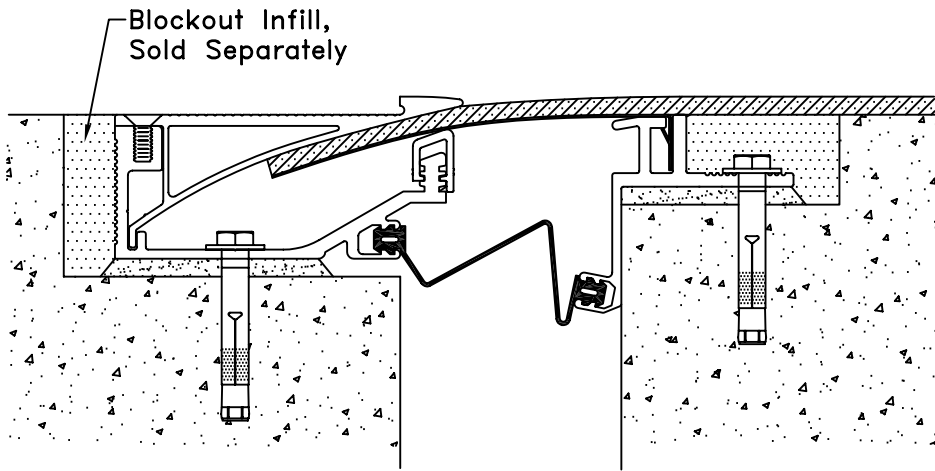

13

Install Grout into blockout on the base support side.
Note: Protect surfaces during placement of blockout infill.

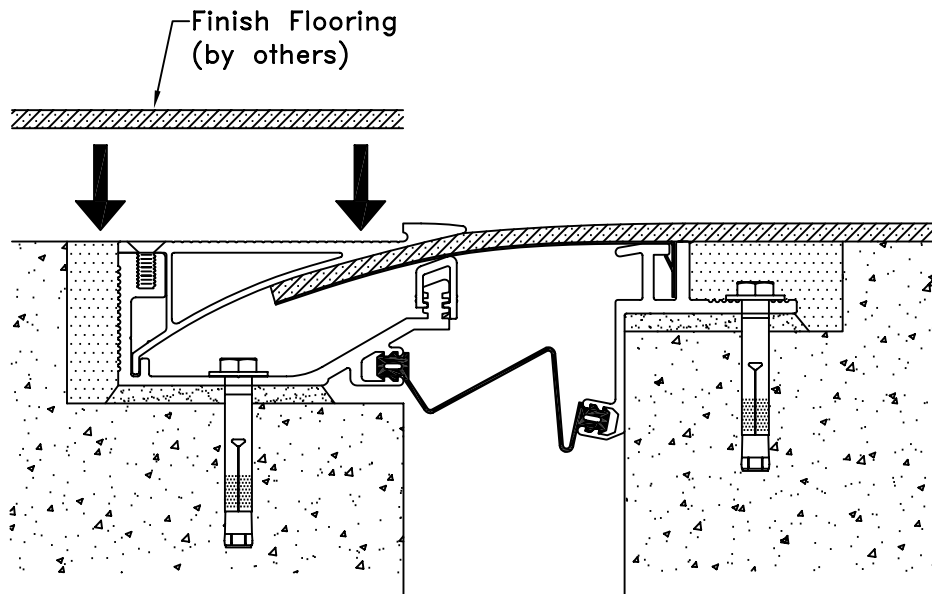

14

Finish installing flooring material on trim piece, following flooring manufacturers application procedures for proper installation of flooring material.