

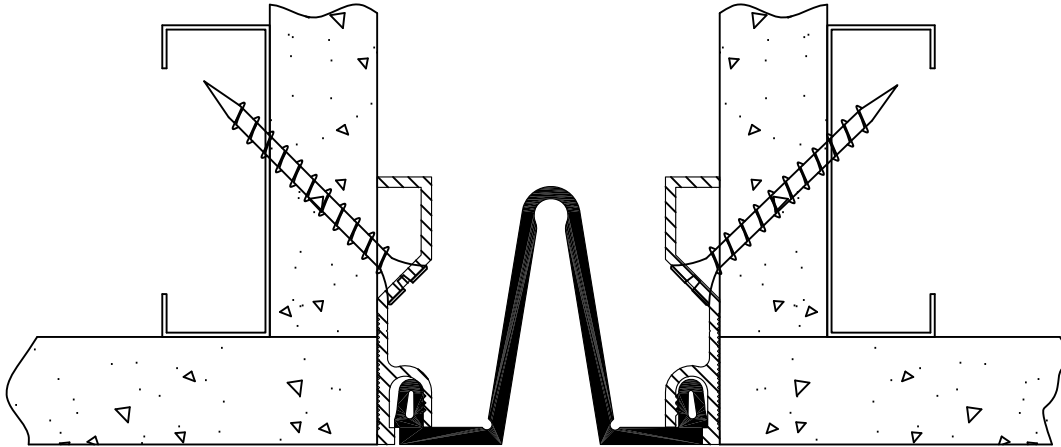

Erie Metal Specialties, Inc.  
13311 Main Road  
Akron, NY 14001

Phone: 716-542-3991  
Website: [www.eriametal.com](http://www.eriametal.com)  
E-Mail: [sales@eriametal.com](mailto:sales@eriametal.com)



## Seal Wall - Standard Series Model(s) "ELCH-200/300/400/500/600" & ELCH-200W/300W/400W/500W/600W Vertical Expansion Control Systems

The following installation procedure is very important and must be fully understood prior to beginning any work. To ensure proper installation and performance of expansion joint system the following actions must be completed by the installing contractor. Failure to do so will affect product warranty.

- 1) Carefully read and understand installation procedure. Contact Technical Service Department for product assistance.
- 2) Inspect all shipments and materials for missing or damaged components and hardware. Contact Customer Service with order number and invoice for prompt assistance.
- 3) Inspect substrate or adjacent construction for acceptance before beginning work. Report unacceptable construction to the project manager for scheduled repair work.

PN: 28051A

# Standard Components

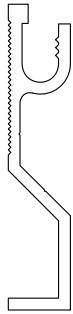

Wall Mount Extrusion  
Part Number-27427

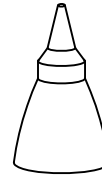

\*\*SI 750 Adhesive  
Part Number - 27514

\*\*Optional components for splice procedures. Place order for required quantities.

Components shown below vary in size depending on model of system



**ELCH-200/200W**

Model	Seal Part Number			
	Black Seal	White Seal	Grey Seal	Beige Seal
ELCH-200/200W	28009	28010	28011	28012
ELCH-300/300W	28013	28014	28015	28016
ELCH-400/400W	28017	28018	28019	28020
ELCH-500/500W	28021	28022	28023	28024
ELCH-600/600W	28025	28026	28027	28028



**ELCH-300/300W**

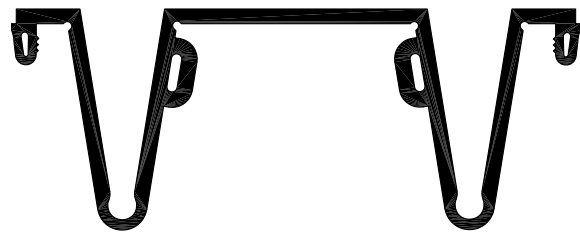

**ELCH-400/400W  
ELCH-500/500W**

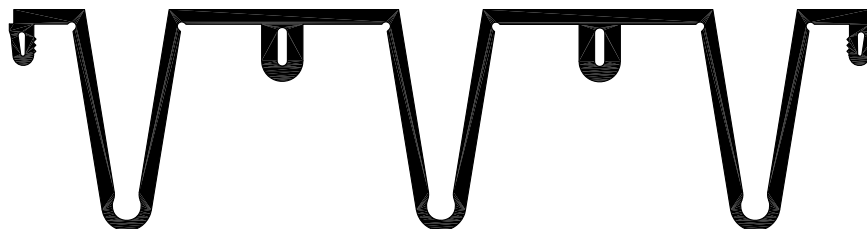

**ELCH-600/600W**

# Installation Procedure

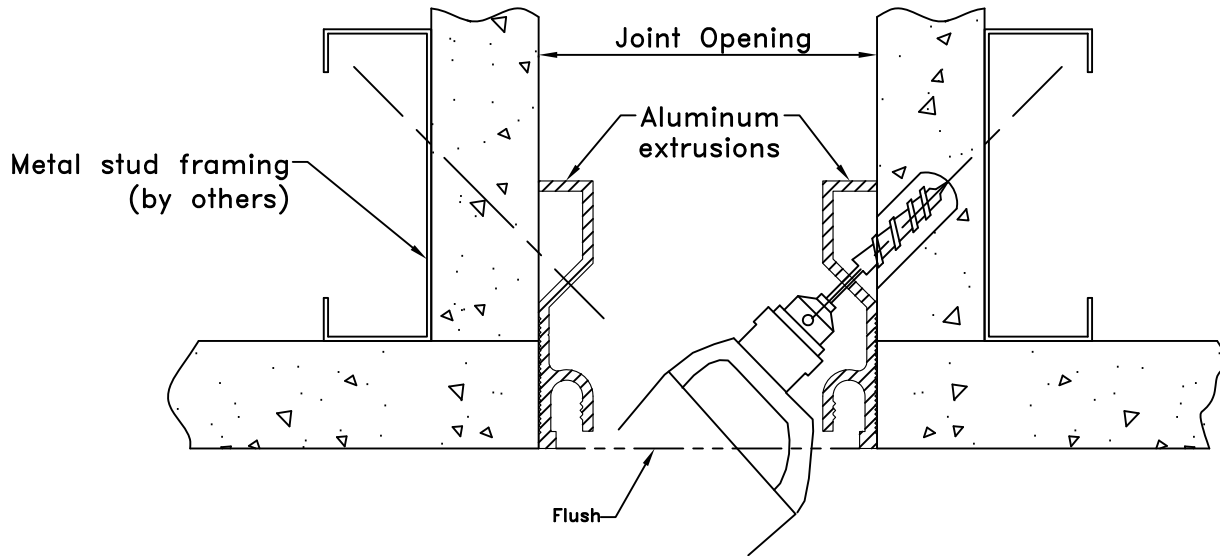

**1** Position aluminum extrusions and mark hole locations. Drill holes through aluminum flange and metal stud framing for drywall screws @ 18" O.C. utilizing a countersink drill.

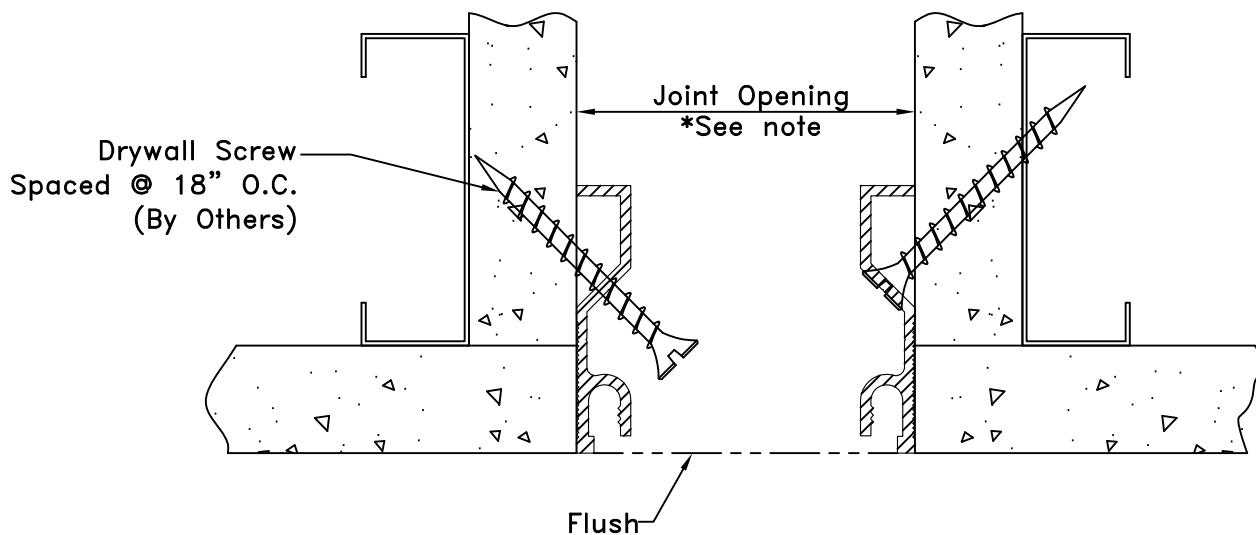

**2** Utilizing a screwdriver, secure aluminum extrusions to wall with drywall screws (by others). Ensure that countersunk heads are sufficiently recessed to allow proper finishing of wall surface.

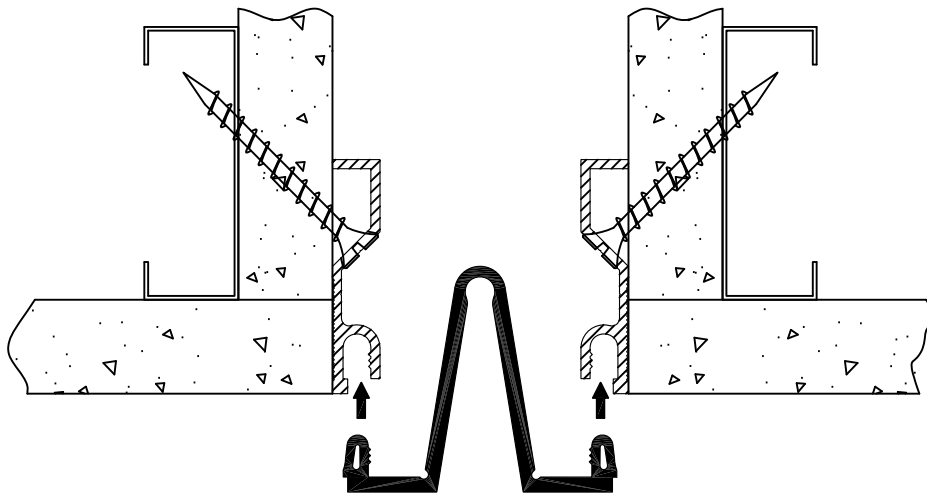

3

Squeeze or slide elastomeric seal into the cavities of the aluminum extrusion.

---

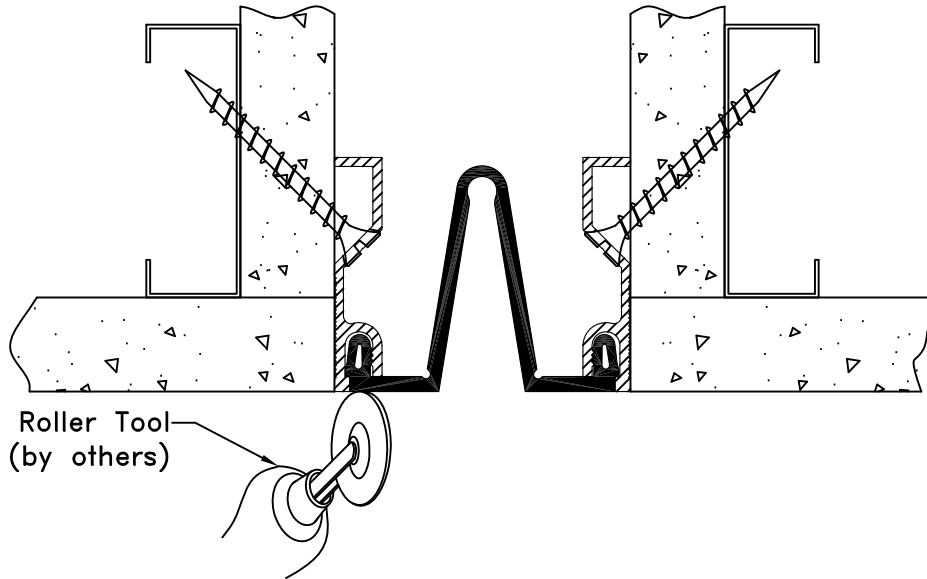

4

Utilizing roller tool apply pressure directly over locking lug to ensure proper engagement of seal lug.

## Suggested Field Splice Procedure

1. Cut ends of seal with a sharp knife and miter box to the desired angle. Insure that cuts are clean and straight.
2. Clean ends of seal with a solvent.
3. Apply SI 750 Adhesive to one of the two seal ends to be bonded.
4. Apply pressure bringing the two surfaces into tight contact immediately after adhesive is applied. Hold in place for one to two minutes for initial bond.
5. Re-Check quality of all splices/miters and apply adhesive as required.
7. It is usually recommended to allow 15 minutes prior to installing seal. To achieve proper working strength care shall be exercised as a result that it takes 24 hours for adhesive to fully cure.

