

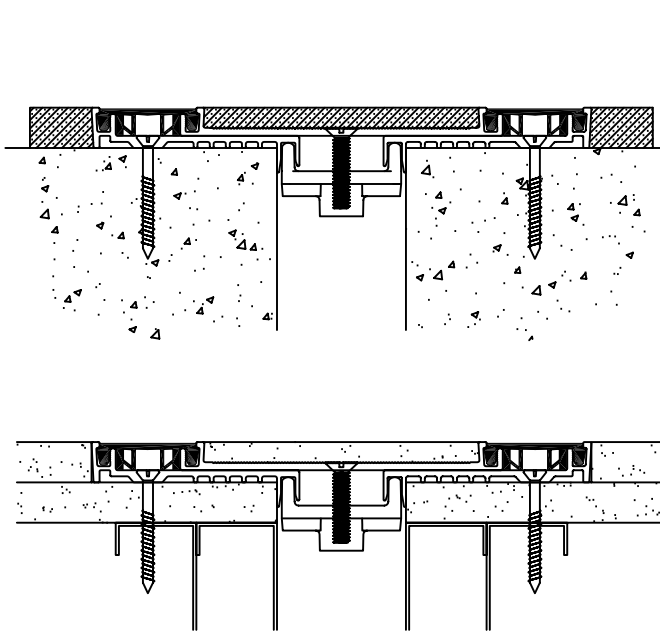

Erie Metal Specialties, Inc.  
13311 Main Road  
Akron, NY 14001

Phone: 716-542-3991  
Website: [www.eriemetal.com](http://www.eriemetal.com)  
E-Mail: [sales@eriemetal.com](mailto:sales@eriemetal.com)



Model - ETMM Floor Condition

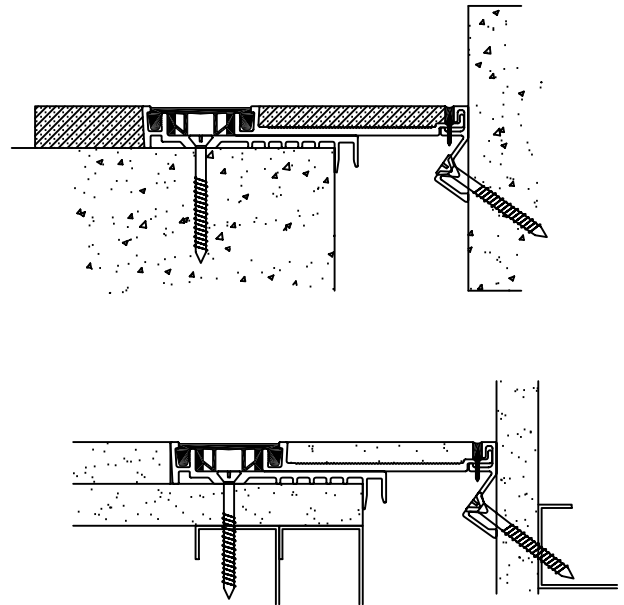

Model - ETMMW Corner Condition

## Double Seam - Standard Series Model(s) ETMM & ETMMW-Corner Horizontal & Vertical Expansion Control Systems

The following installation procedure is very important and must be fully understood prior to beginning any work. To ensure proper installation and performance of expansion joint systems the following actions must be completed by the installing contractor. Failure to do so will affect product warranty.

- 1) Carefully read and understand installation procedure. Contact Technical Service Department for product assistance.
- 2) Inspect all shipments and materials for missing or damaged components and hardware. Contact Customer Service with order number and invoice for prompt assistance.
- 3) Inspect substrate or adjacent construction for acceptance before beginning work. Report unacceptable construction to the project manager for scheduled repair work.

# Standard Components



No. 12 x 1 <sup>3</sup>/<sub>4</sub>" Lg. Threaded Concrete Anchor  
Part Number - 6530

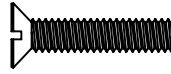

<sup>1</sup>/<sub>4</sub>" Dia. x 2" Lg. Stainless Steel Flathead Screw  
Part Number - 5682

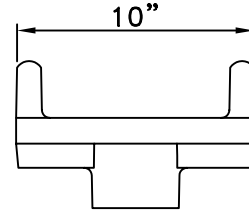

Seismic Centering Bar  
Part Number - 11120

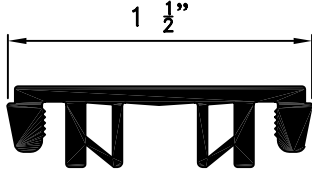

Elastomeric Seal  
P/N - 17101 (Black)  
P/N - 17102 (Gray)  
P/N - 17103 (Beige)  
P/N - 17104 (White)

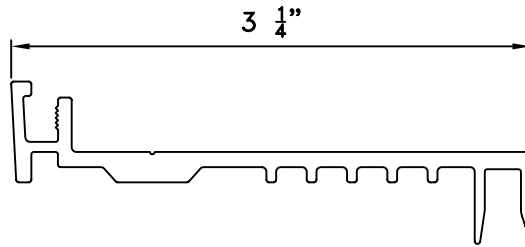

Aluminum Base Extrusion  
Part Number - 20701

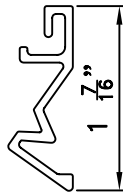

\*Wall Mount Aluminum Extrusion  
Part Number - 11206

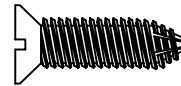

\*No. 6 Screw  
Part Number - 5719

Components shown below vary in size depending on model of system

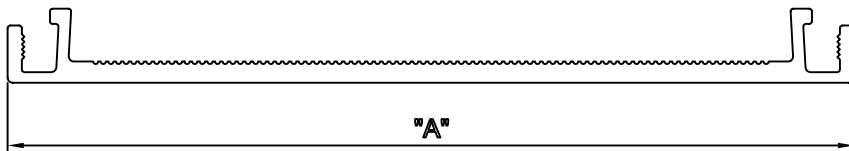

Aluminum Slide Plate

Dimensional Chart		
Model	Part Number	"A"
ETMM-200	20702	5"
ETMM-400	20703	7"
ETMM-600	20704	9"

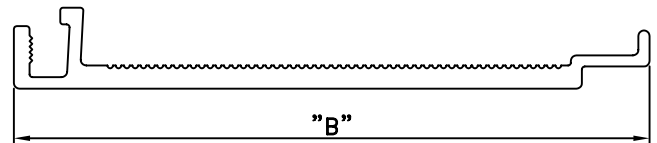

\*Aluminum Slide Plate

Dimensional Chart		
Model	Part Number	"B"
ETMM-200W	20705	3.432"
ETMM-400W	20706	5.432"
ETMM-600W	20708	7.432"

# Installation Procedure For Floor Condition

## Step 1

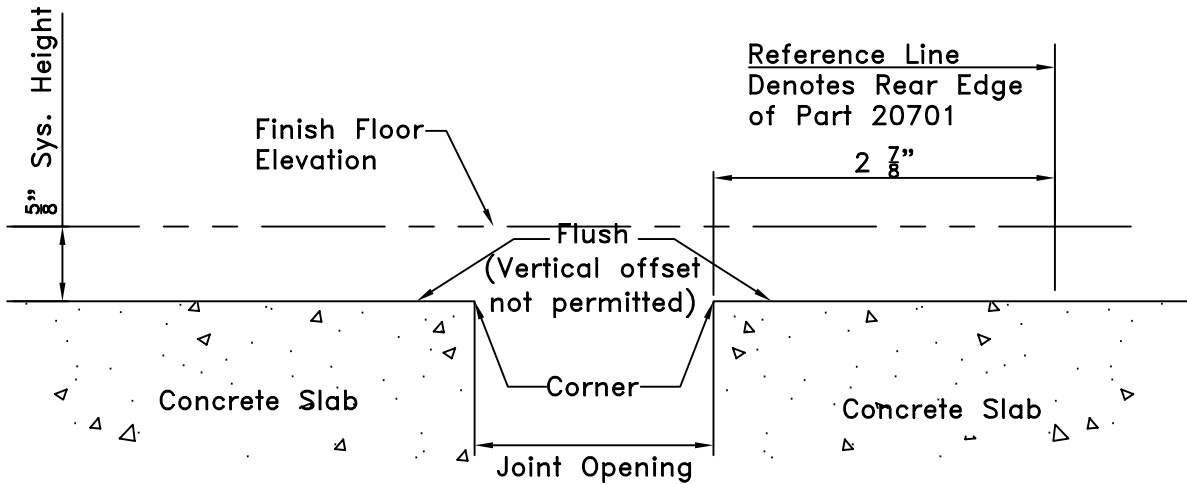

Floor – Prior to beginning work, installer shall inspect corners of concrete slab for acceptability.

## Wall to Wall

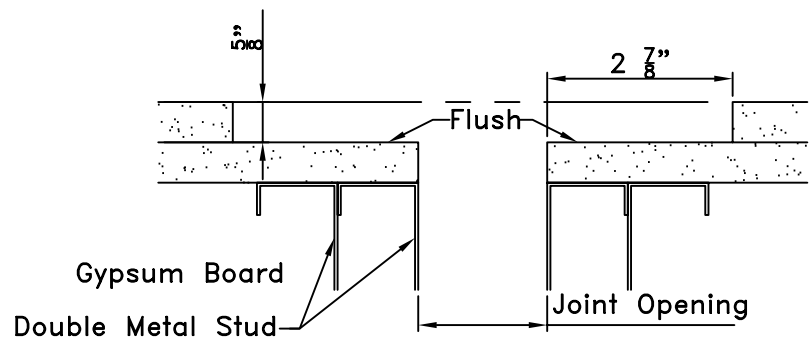

Wall – Prior to beginning work, installer shall inspect corners of Gypsum Board for acceptability.

## Step 2

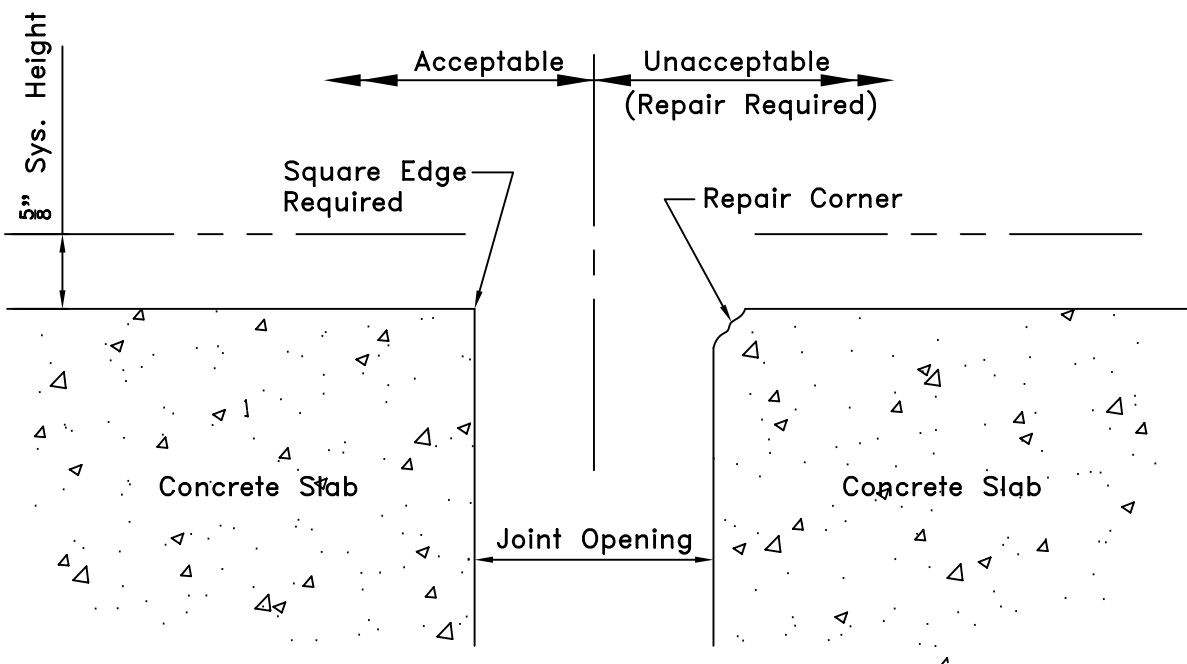

Repair corner of concrete slab following manufacturers written instructions.

## Step 3

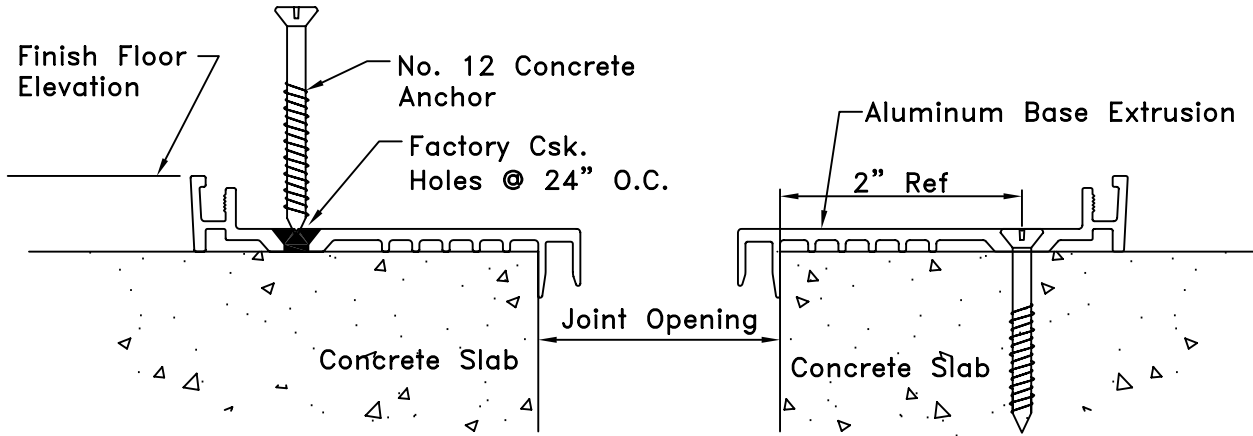

**Floor** – Utilizing manufacturers Threaded Concrete Anchors, mount & secure Aluminum Base Extrusion to concrete slab. Butt all ends tight between standard lengths of aluminum base extrusion.

**Note:** Drill Holes for concrete anchors by utilizing  $\frac{5}{32}$ " Carbide Masonry Drill Bits.

**Wall** – Utilizing manufacturers Threaded Concrete Anchors, mount & secure Aluminum Base Extrusion to wall construction and metal stud. Butt all ends tight between standard lengths of aluminum base extrusion.

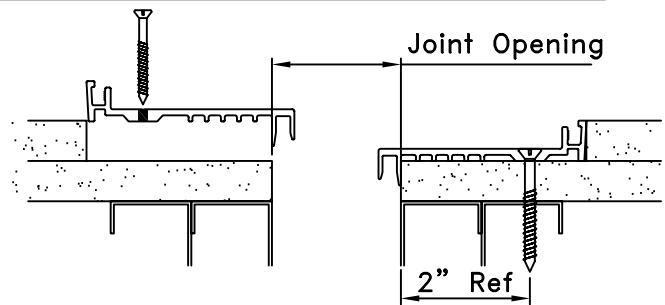

**Note:** Since construction is not concrete installer may continue to utilize supplied anchor if substrate is Wood, Plastic or Thin Metal. In such case, predrilling hole is typically not required.

## Step 4

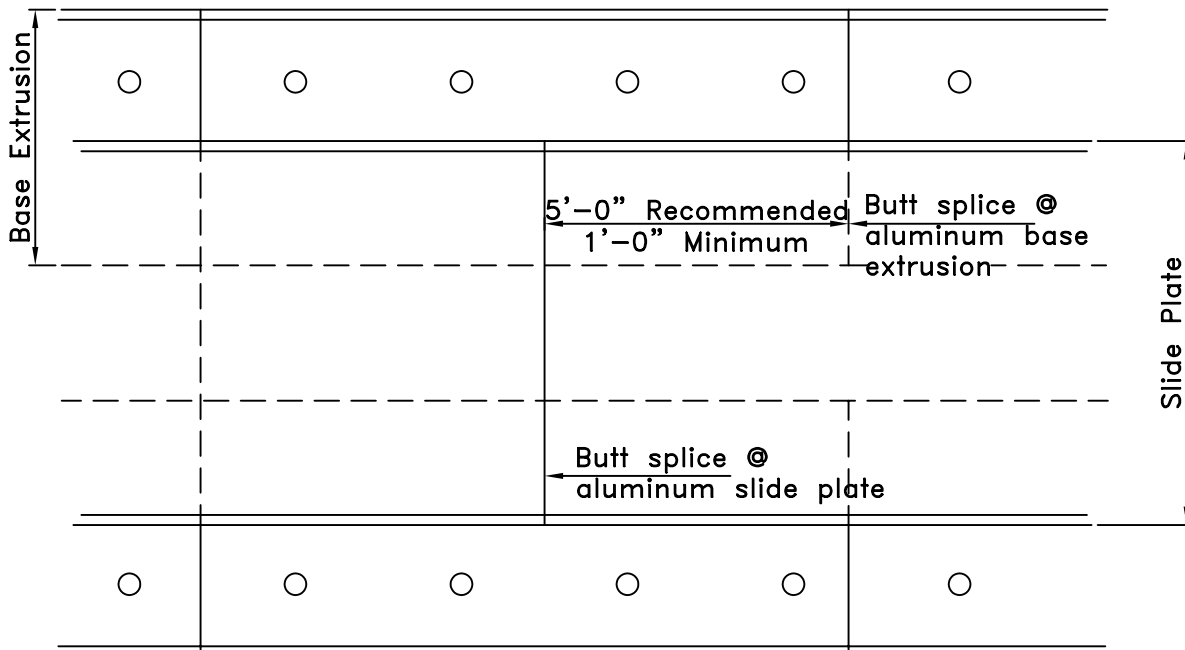

– Stagger all splices in accordance with detail illustrated above to provide a stronger assembly and durable installation.

## Step 5

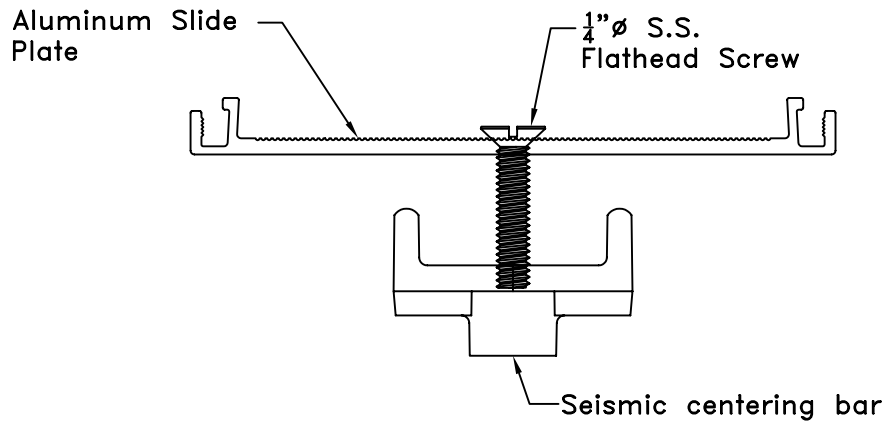

– Insert S.S. Flathead Screw into Aluminum Slide plate and Seismic Centering bar. Partially thread screw through centering bar by allowing bar 2–3 full turns after engagement.

---

## Step 6

### Side View

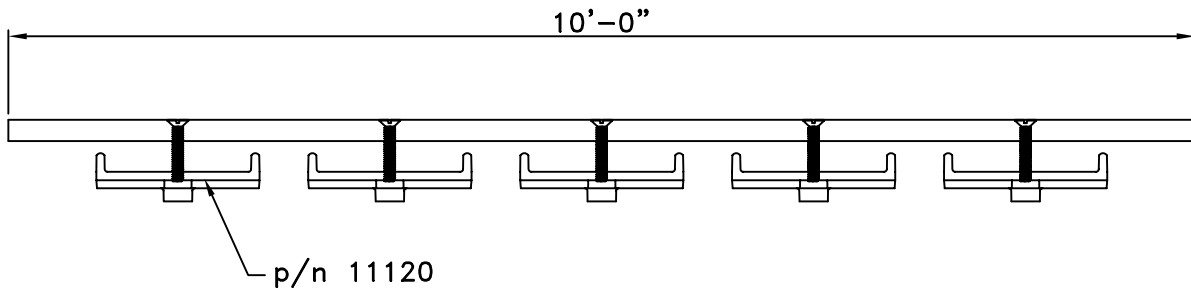

### Top View

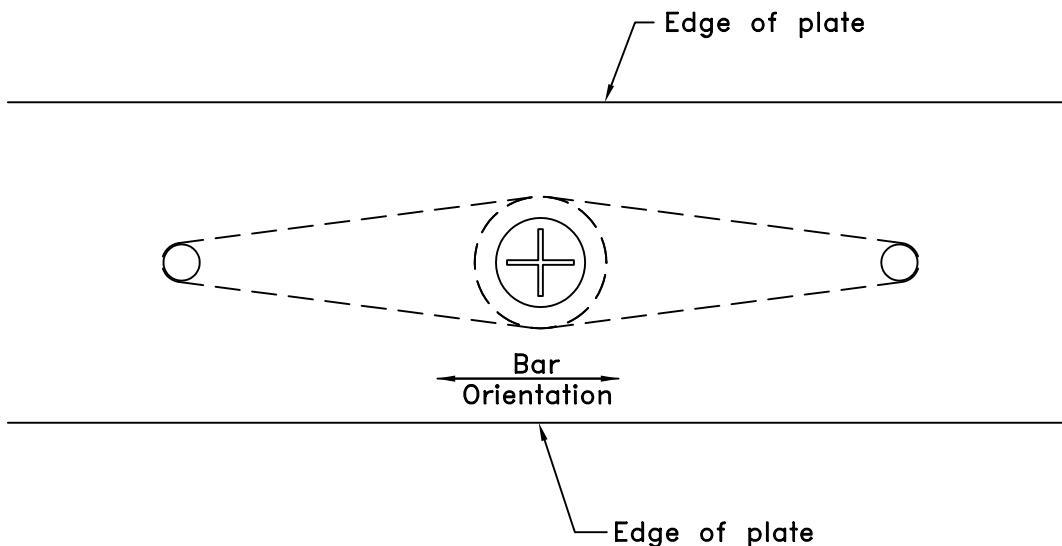

– Step 5 must be complete for all seismic centering bars that will be utilized to secure a standard 10 foot section of slide plate. Centering bars must be oriented parallel to edge of plate to allow for proper insertion into opening and base extrusion channel.

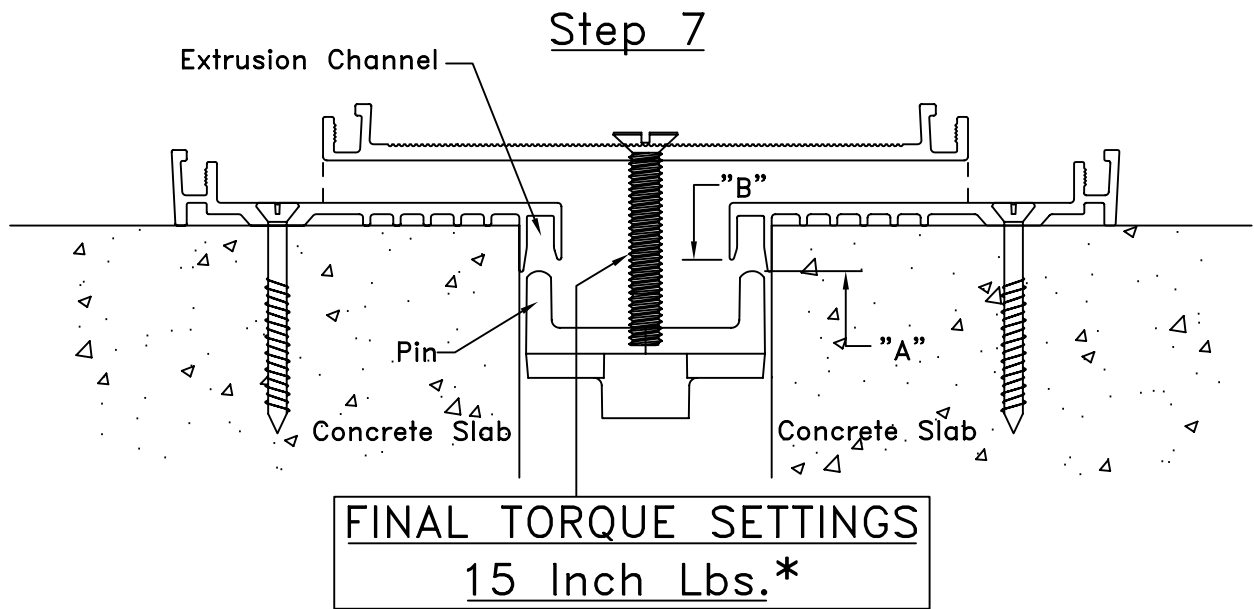

- Center and lower slide plate into opening. Reference point "A" must be lower than point "B" to permit proper installation.
- Turn screw clockwise to rotate centering bar permitting alignment of pins directly below extrusion channel. With continuous motion, thread screw allowing vertical engagement between pin and channel. Visually inspect for proper engagement prior to final tightening of screws.
- Utilizing inch-lbs clicker torque wrench, make final adjustment on all screws.
- Installation Tip: Calibrate battery operated drill/driver to proper inch-lb setting. Periodically inspect for proper torque setting utilizing clicker wrench.

**CAUTION:** Over tightening of screws may VOID warranty.

\*Armstrong Torque wrench #64-031 used to verify settings.

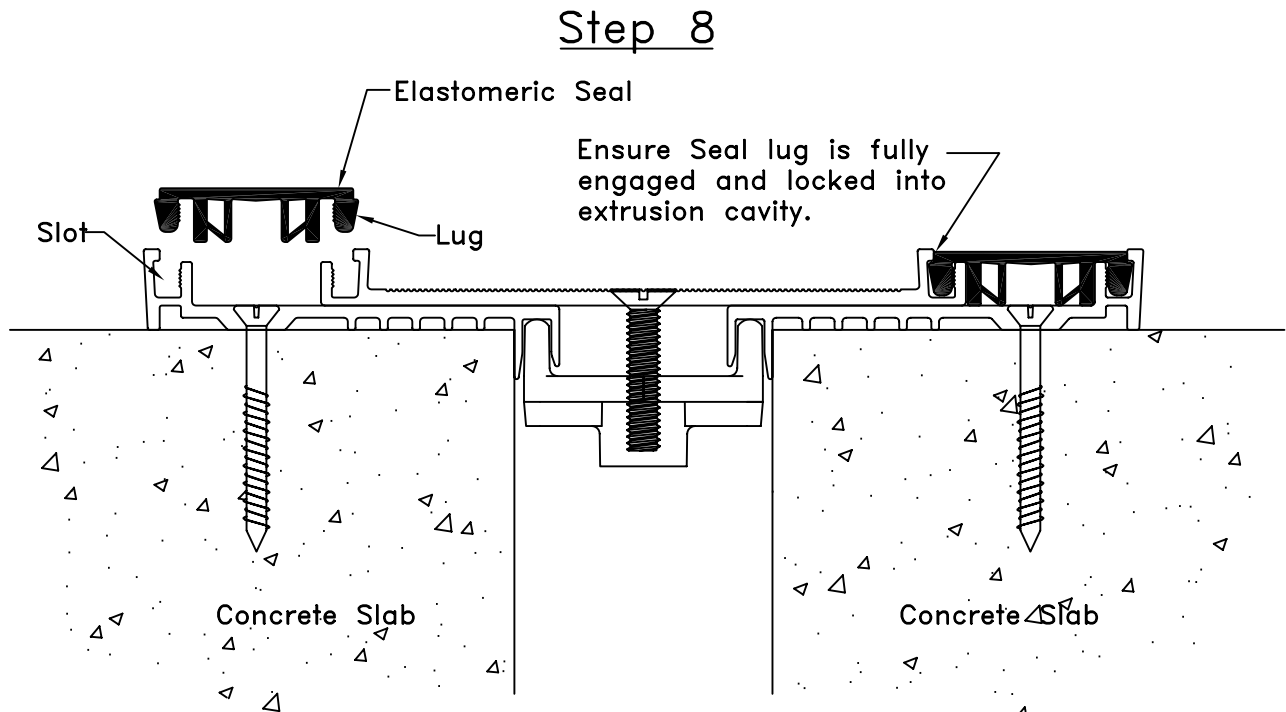

- Insert Elastomeric Seal into slots of Aluminum Base Extrusion and Aluminum Slide plate, exercising care not to damage Elastomeric Seal.

## Step 9

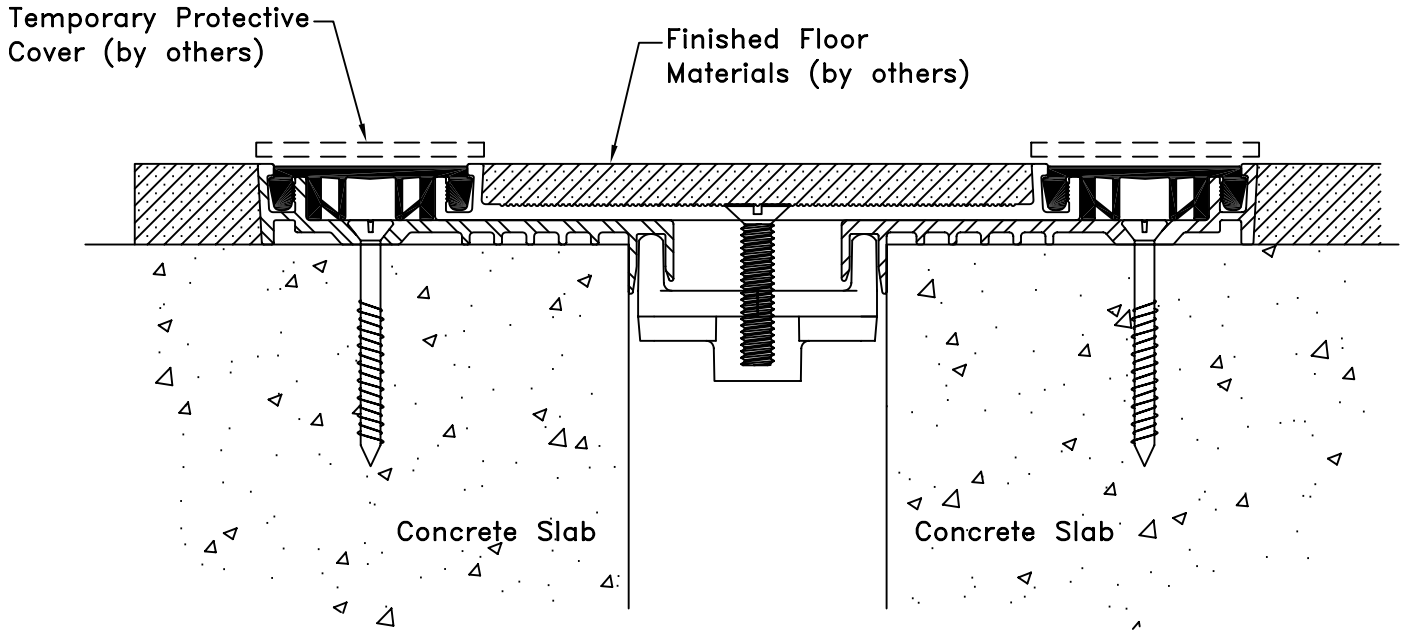

– Install finish flooring material. For flooring applications refer to sheet 12.

Note: Installing contractor shall cover and protect finished expansion joint assembly from damage during installation of finished floor materials. The expansion joint assembly is a finished product. Damage to expansion joint finishes and components ARE excluded from warranty.

# Installation Procedure For Corner Condition

## Step 1

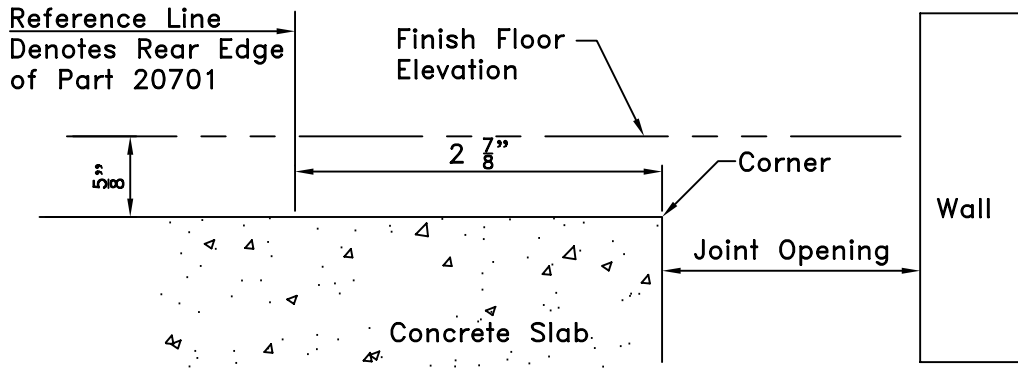

**Floor** – Prior to beginning work, installer shall inspect corners of concrete slab for acceptability.

### Wall to Wall

**Wall** – Prior to beginning work, installer shall inspect corners of Gypsum Board for acceptability.

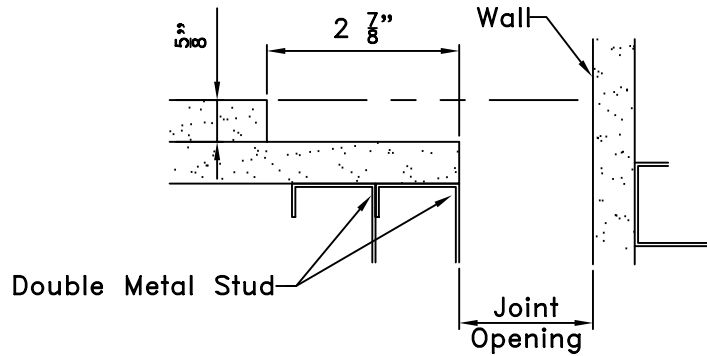

## Step 2

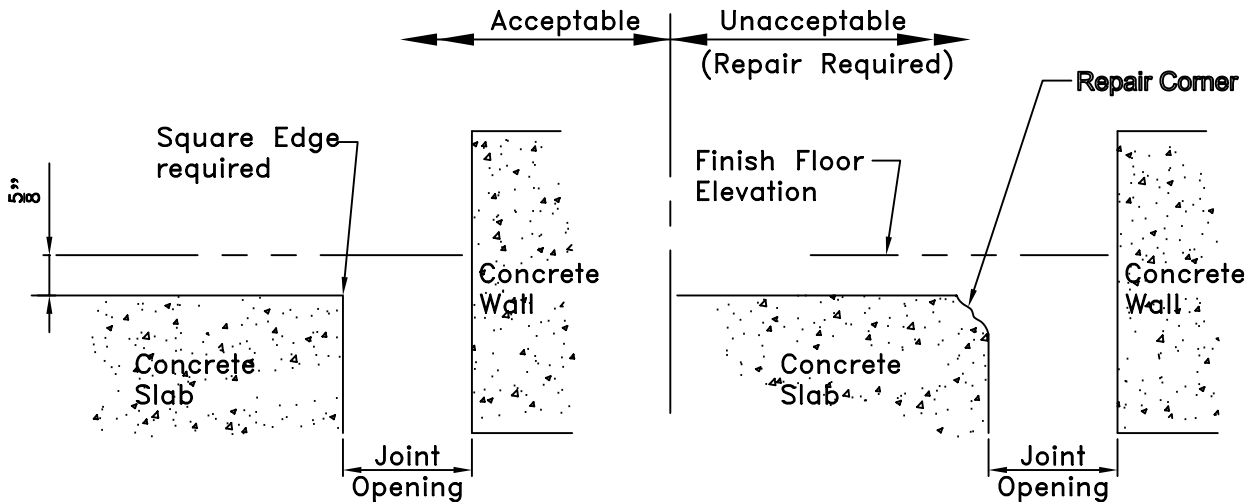

Repair corner of concrete slab following manufacturers written instructions.



# Step 3

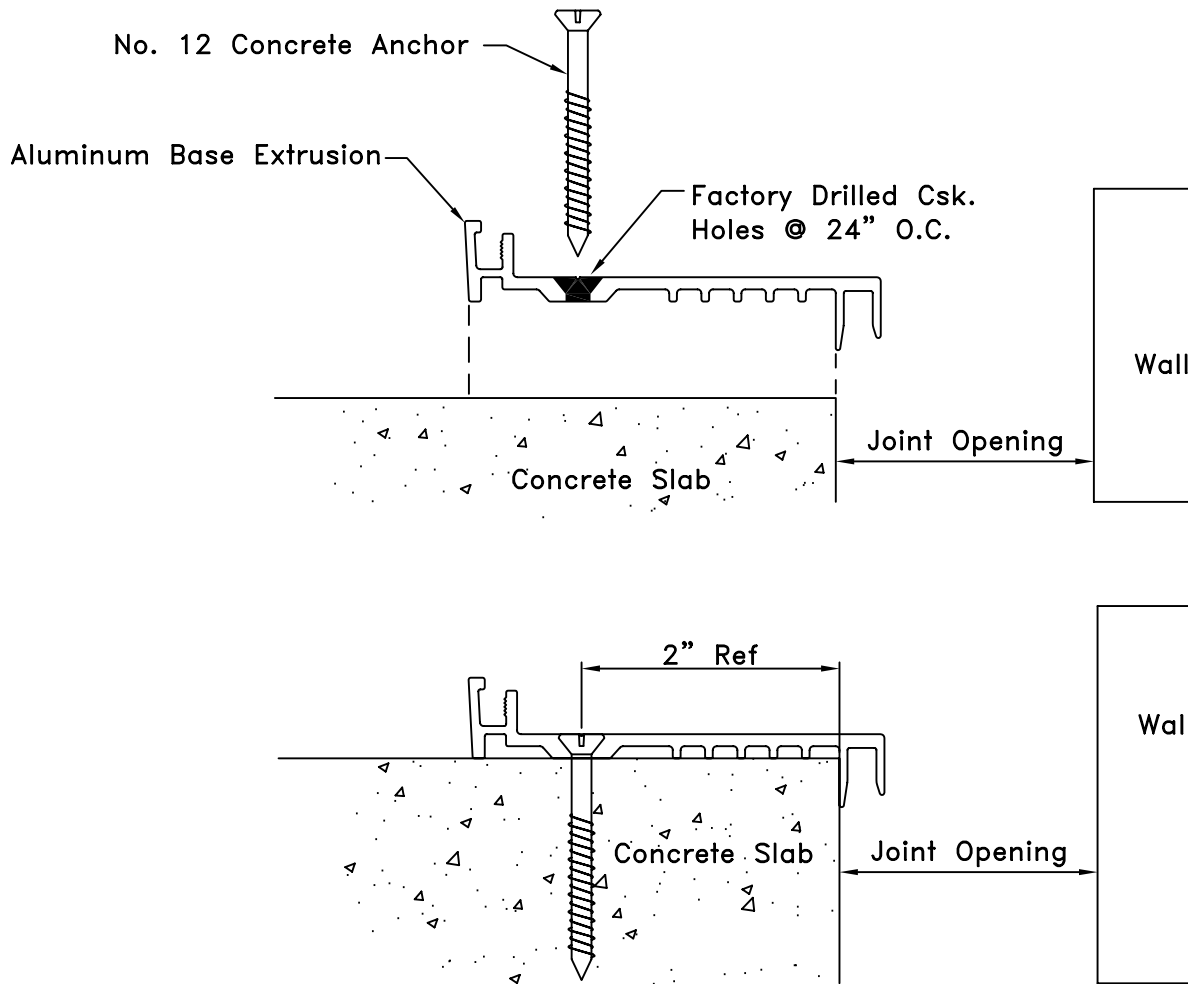

**Floor** – Utilizing manufacturers Threaded Concrete Anchors, mount & secure Aluminum Base Extrusion to concrete slab.

– Butt all ends tight between standard lengths of aluminum base extrusion.

**Note:** Drill Holes for concrete anchors by utilizing 5/32" Lg Carbide Masonry Drill Bits.

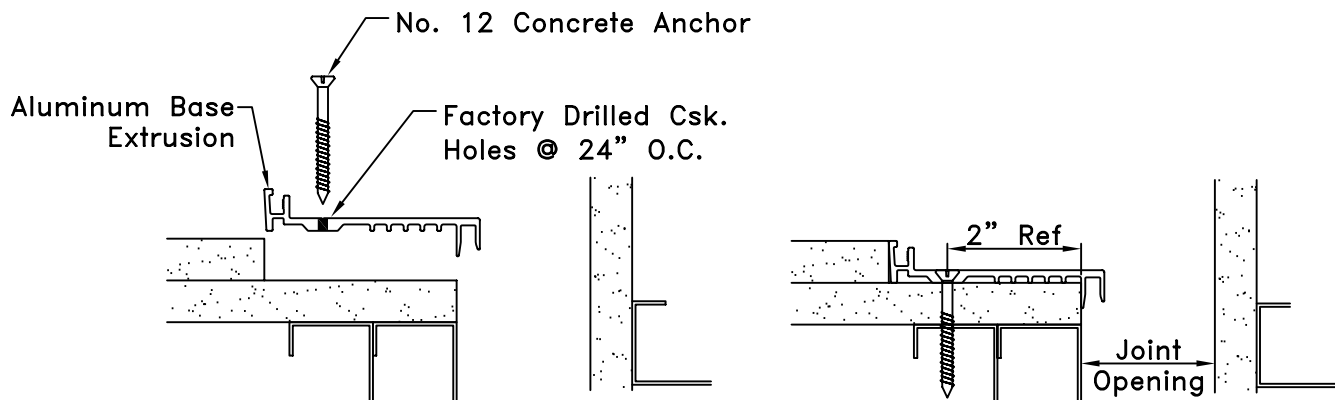

**Wall** – Utilizing manufacturers Threaded Concrete Anchors, mount & secure Aluminum Base Extrusion to wall construction & metal stud.

– Butt all ends tight between standard lengths of aluminum base extrusion.

**Note:** Since construction is not concrete installer may continue to utilize supplied anchor if substrate is Wood, Plastic or Thin Metal. In such case, predrilling hole is typically not required.

## Step 4

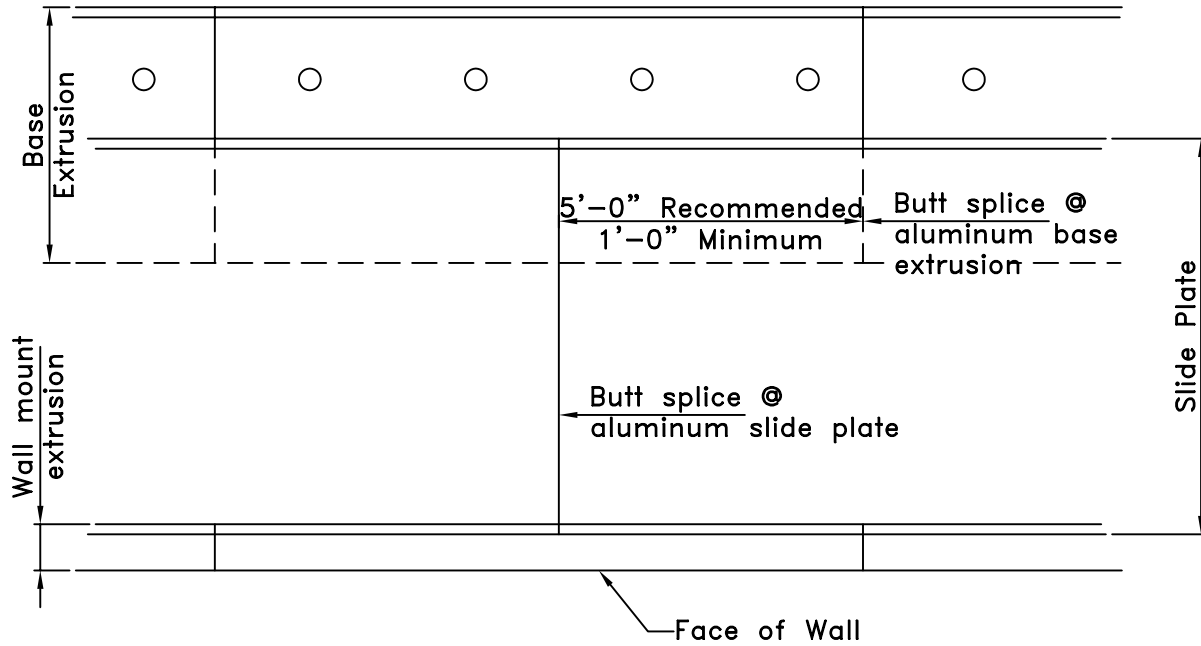

– Stagger all splices in accordance with detail illustrated above to provide a stronger assembly and durable installation.

## Step 5

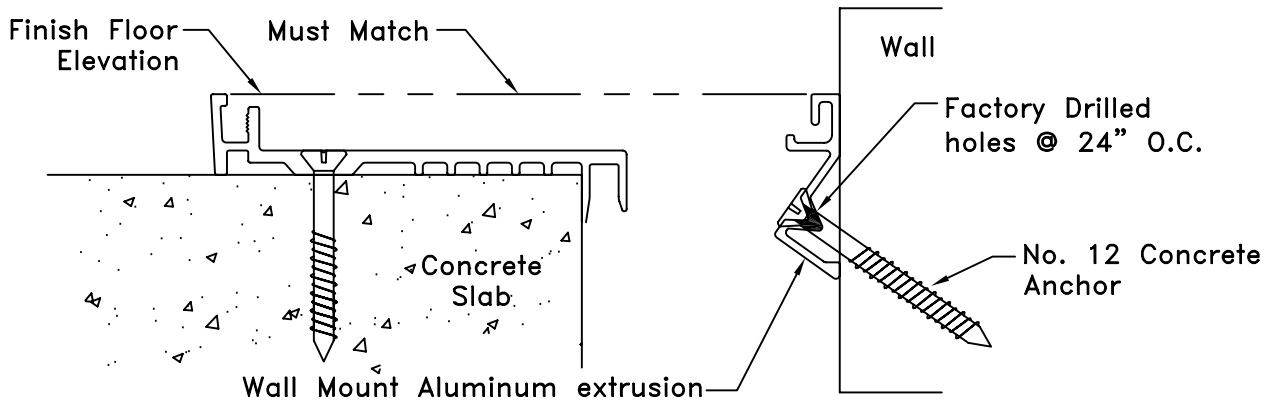

**Floor** – Utilizing manufacturers Threaded Concrete Anchors, mount & secure Aluminum Base Extrusion to concrete slab.

– Butt all ends tight between standard lengths of aluminum base extrusion.

Note: Drill Holes for concrete anchors by utilizing  $\frac{5}{32}$ " Lg Carbide Masonry Drill Bits.

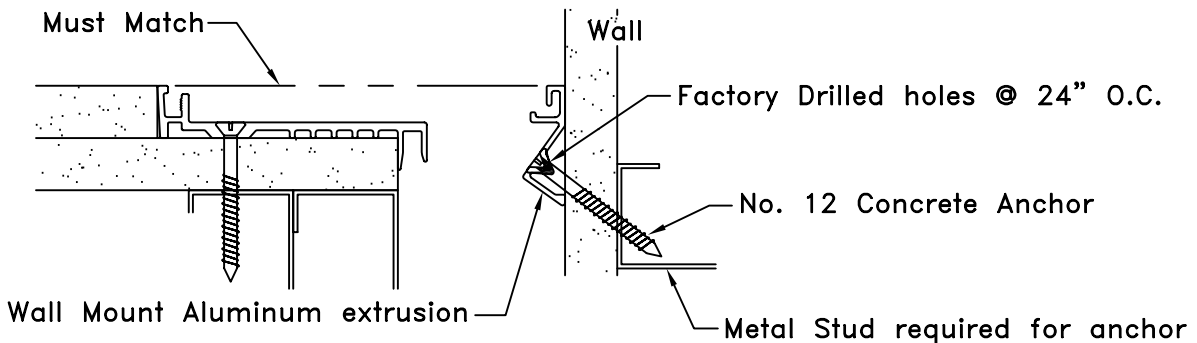

**Wall** – Utilizing manufacturers Threaded Concrete Anchors, mount & secure Wall Mount Aluminum Extrusion to wall construction & metal stud.

– Butt all ends tight between standard lengths of aluminum base extrusion.

Note: Since construction is not concrete installer may continue to utilize supplied anchor if substrate is Wood, Plastic or Thin Metal. In such case, predrilling hole is typically not required.

## Step 6

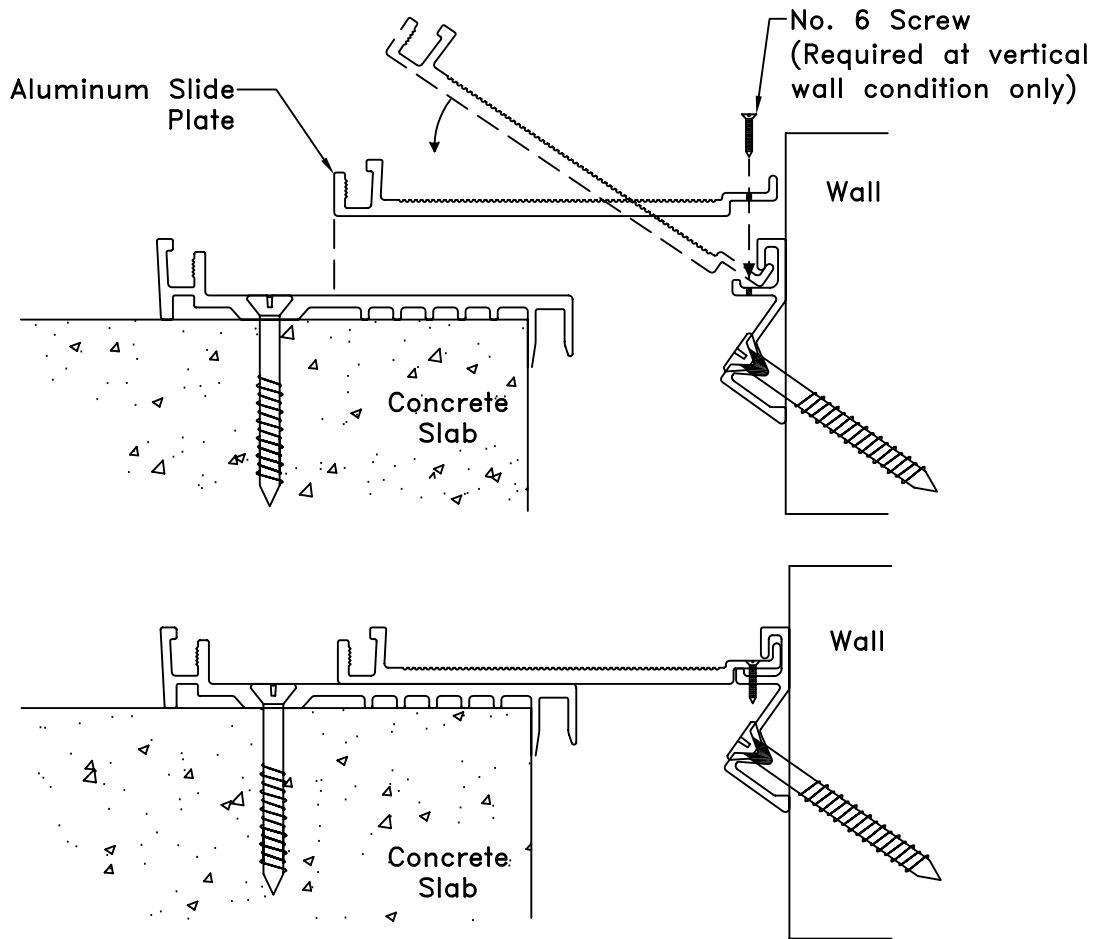

- Mount & secure Aluminum Slide Plate to Wall Mount Aluminum Extrusion. Utilize No. 6 Screw at vertical wall installation to maintain contact of slide plate to wall surface.
- Butt all ends tight between standard lengths of aluminum base extrusion.

## Step 7

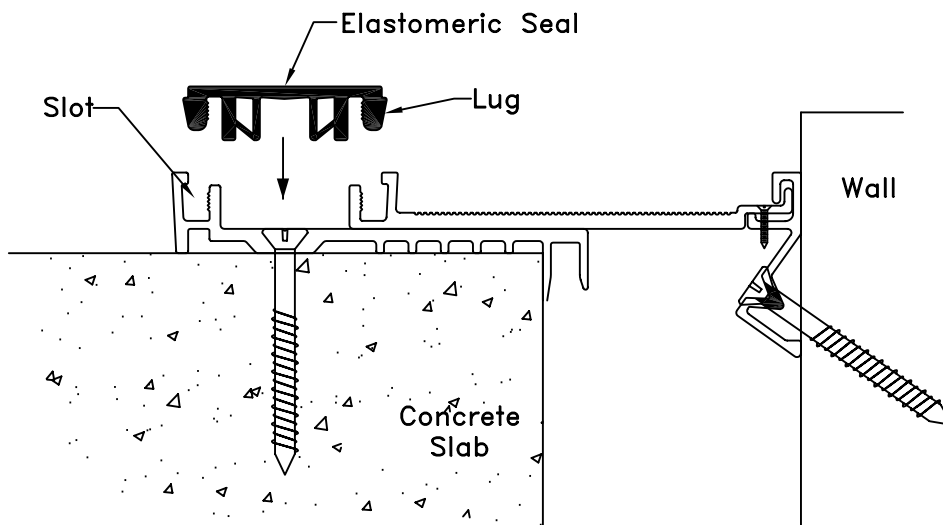

- Insert Elastomeric Seal into slots of the Aluminum Base Extrusion and Aluminum Slide plate, exercising care not to damage Elastomeric Seal.

## Step 8

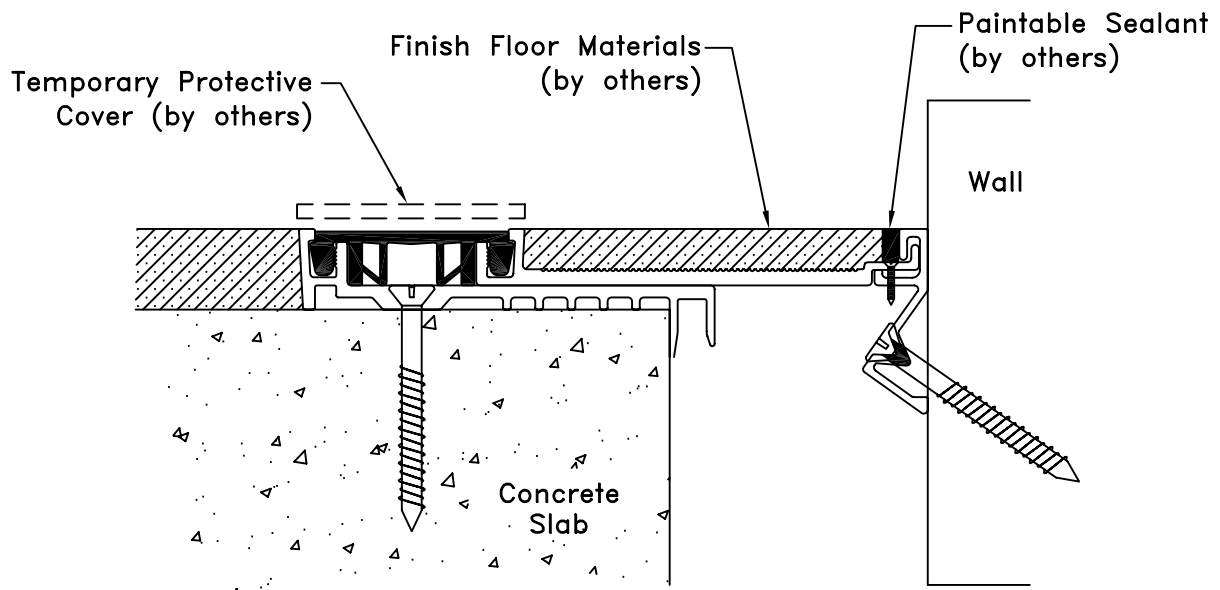

– Install finish flooring material. For flooring applications refer to sheet 12.

Note: Installing contractor shall cover and protect finished expansion joint assembly from damage during installation of finished floor materials. The expansion joint assembly is a finished product. Damage to expansion joint finishes and components ARE excluded from warranty.

**"A" Carpet Detail**  
(Minimal Blockout)

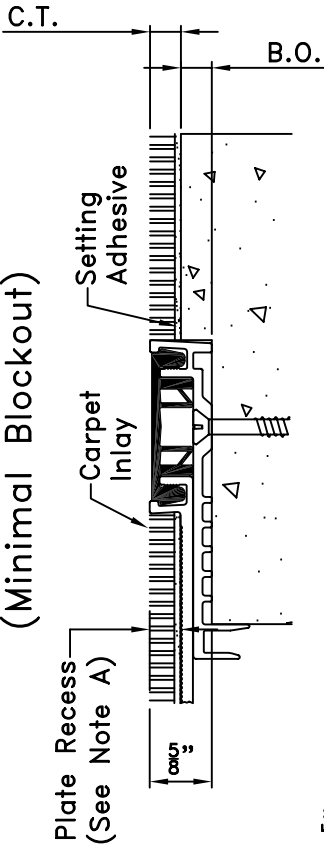

- \* B.O. =  $\frac{5}{8}$ " - C.T.
- \* C.T. denotes carpet thickness with adhesive.
- \* No B.O. required for  $\frac{5}{8}$ " thick carpet.

**"D" Alternate Carpet Detail**  
(No Blockout)

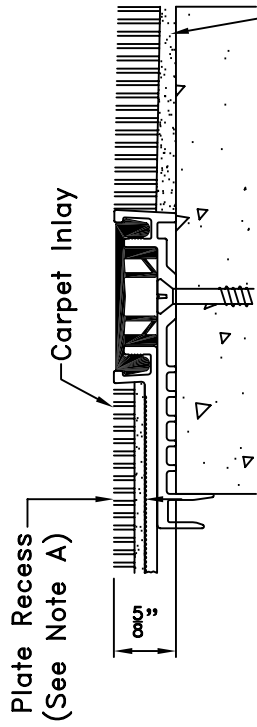

- \* Taper patch material away from expansion joint.
- \* Thickness of patch dependent on carpet thickness.
- \* No patch required for  $\frac{5}{8}$ " thick carpet.

**"B" Tile Detail**

Proper Method For Termination of Tile  
To Be Determined By Installing  
Contractor

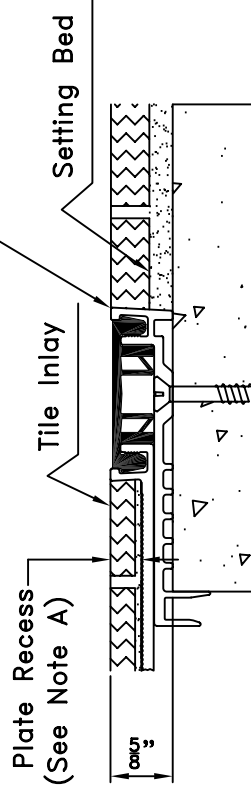

**"C" Terrazzo Detail**

Proper Method For Termination of Terrazzo  
To Be Determined By Installing Contractor

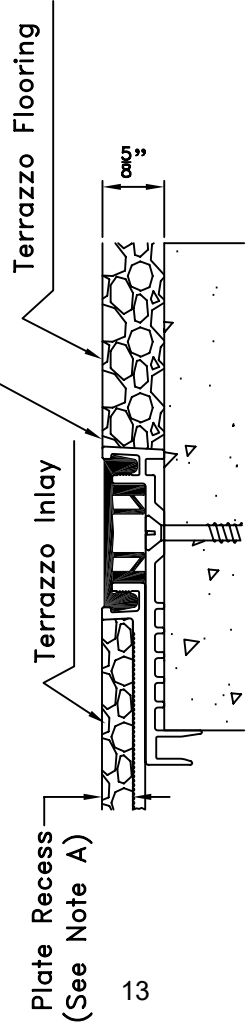

**"E" 1/8" VCT or Sheet Vinyl Detail**  
(Minimal Blockout)

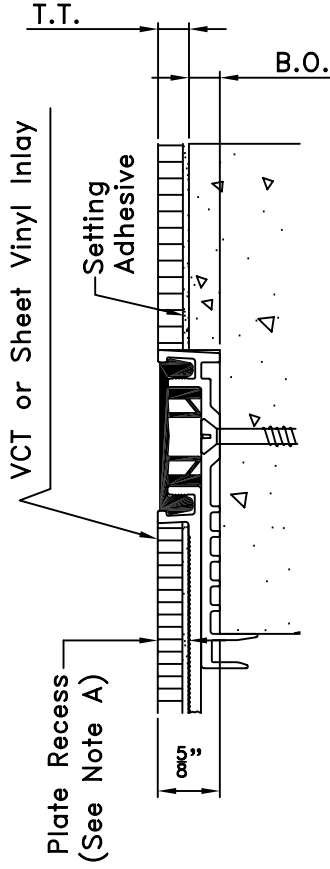

- \* B.O. =  $\frac{5}{8}$ " - T.T.
- \* T.T. denotes tile thickness with adhesive.

- Note A: Plate Recess**
- \*  $\frac{9}{32}$ " @ ETMM-W 200, 400
  - \*  $\frac{5}{16}$ " @ ETMM-W600