

SEAL COLOR SELECTOR			
BLACK	_____	WHITE	_____
BEIGE	_____	GRAY	_____

ACOUSTICAL CEILING-WALL SYSTEM
 EXPOSED FINISH: MILL
 MOVEMENT: +/-25% NOMINAL JOINT WIDTH
 STOCK LENGTHS: 10'-0"

PRODUCT	Application	Joint Size "A" @ Mean T°F	Exposed Site line "B" IN (MM)	Total Movement IN (MM)
ELCA-100	Ceiling	1.00" (25)	1.00" (25)	0.50" (13)
ELCA-100W	Ceiling Corner	1.00" (25)	1.37" (35)	0.50" (13)

NO.	Description	Date	By
<small>The information contained herein is the proprietary property of ERIE METAL SPECIALTIES, INC. No portion of it may be reproduced by any means or used in any form except for the purpose for which it was intended. All rights of design and invention are hereby reserved.</small>			



13311 Main Road * Akron * New York * 14001
 Phone: (716) 542-3991 * Fax: (716) 542-3996 * E-mail: sales@eriemetal.com

PROJECT:
TITLE: ELCA-100/100W

Detailed by:	Date:
BAF	10/21/17
Checked by:	Date:
SLP	10/21/17
Scale:	EMS Job #:
NTS	
Sheet No.:	Drawing No.:
1 of 1	ELCA-1

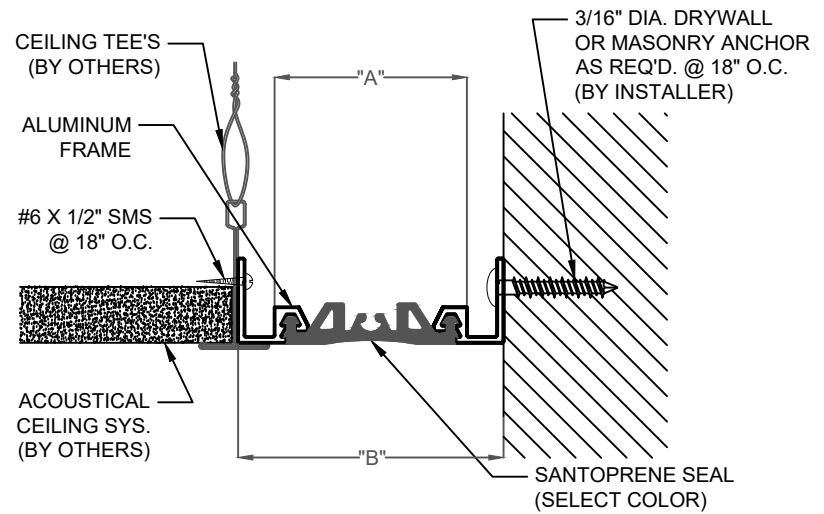
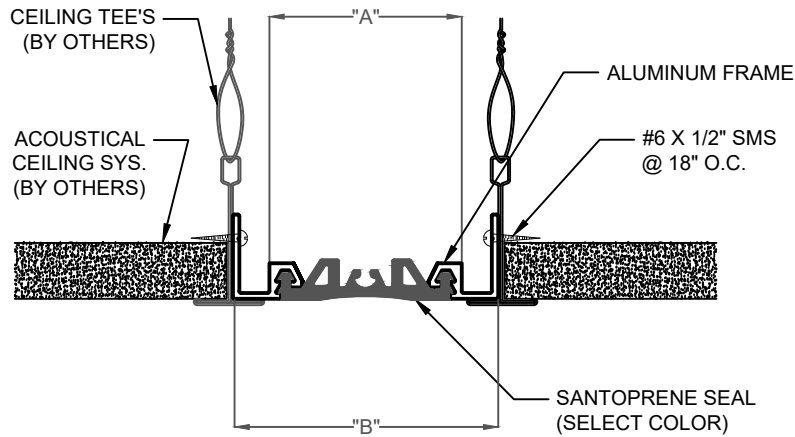

SEAL COLOR SELECTOR			
BLACK	_____	WHITE	_____
BEIGE	_____	GRAY	_____

ACOUSTICAL CEILING-CEILING/WALL SYSTEM
 EXPOSED FINISH: MILL
 MOVEMENT: +/-25% NOMINAL JOINT WIDTH
 STOCK LENGTHS: 10'-0"

PRODUCT	Application	Joint Size "A" @ Mean T°F	Exposed Site line "B" IN(MM)	Total Movement IN (MM)
ELCA-200	Ceiling	2.00" (51)	2.00" (51)	1.00" (25)
ELCA-300	Ceiling	3.00" (76)	3.00" (76)	1.50" (38)
ELCA-200W	Ceiling Corner	2.00" (51)	2.37" (60)	1.00" (25)
ELCA-300W	Ceiling Corner	3.00" (76)	3.37" (85)	1.50" (38)

NO.	Description	Date	By
<small>The information contained herein is the proprietary property of ERIE METAL SPECIALTIES, INC. No portion of it may be reproduced by any means or used in any form except for the purpose for which it was intended. All rights of design and invention are hereby reserved.</small>			



13311 Main Road * Akron * New York * 14001
 Phone: (716) 542-3991 * Fax: (716) 542-3996 * E-mail: sales@eriemetal.com

PROJECT: _____

TITLE: ELCA-200/200W, 300/300W

Detailed by:	Date:
BAF	10/21/17
Checked by:	Date:
SLP	10/21/17
Scale:	EMS Job #:
NTS	
Sheet No.:	Drawing No.:
1 of 1	ELCA-1