

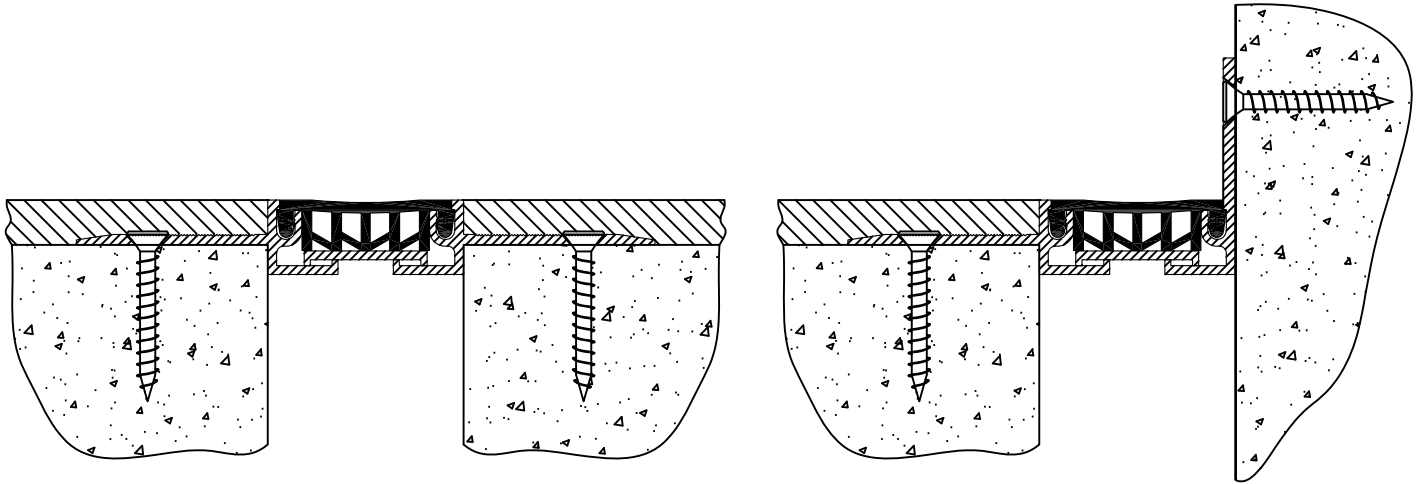

Erie Metal Specialties, Inc.  
13311 Main Road  
Akron, NY 14001

Phone: 716-542-3991  
Website: [www.eriemetal.com](http://www.eriemetal.com)  
E-Mail: [sales@eriemetal.com](mailto:sales@eriemetal.com)



## Seal Flooring - Standard Series Model(s) "ELCFC-100/200" & "ELCFC-100W/200W" Horizontal Expansion Control Systems

The following installation procedure is very important and must be fully understood prior to beginning any work. To ensure proper installation and performance of expansion joint system the following actions must be completed by the installing contractor. Failure to do so will affect product warranty.

- 1) Carefully read and understand installation procedure. Contact Technical Service Department for product assistance.
- 2) Inspect all shipments and materials for missing or damaged components and hardware. Contact Customer Service with order number and invoice for prompt assistance.
- 3) Inspect substrate or adjacent construction for acceptance before beginning work. Report unacceptable construction to the project manager for scheduled repair work.

# Standard Components

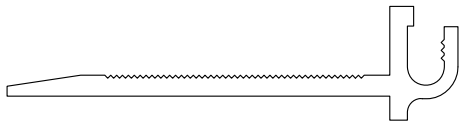

Floor Mount Extrusion  
Part Number-27421  
(for ELCFC-100/100W)



\*Wall Mount Extrusion  
Part Number-27478  
(for ELCFC-100W)

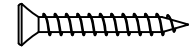

#12 x 1 3/4" Spax Anchor  
Part Number-27506

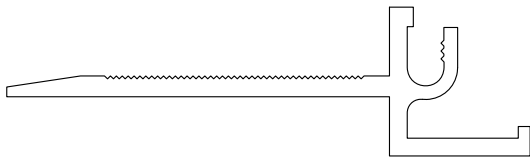

Floor Mount Extrusion  
Part Number-27423  
(for ELCFC-200/200W)

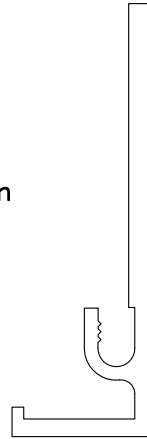

\*Wall Mount Extrusion  
Part Number-27418  
(for ELCFC-200W)

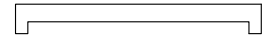

Aluminum Support Plate  
Part Number-27382  
(for ELCFC-200/200W)



\*\*SI 750 Adhesive  
Part Number - 27514

\*Components required for corner condition

\*\*Optional components for splice procedures. Place order for required quantities.

Components shown below vary in size depending on model of system

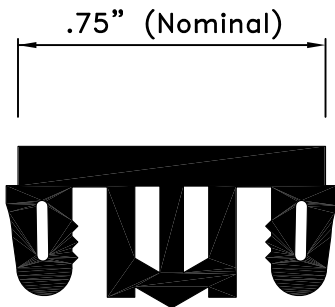

**ELCFC-100/100W**

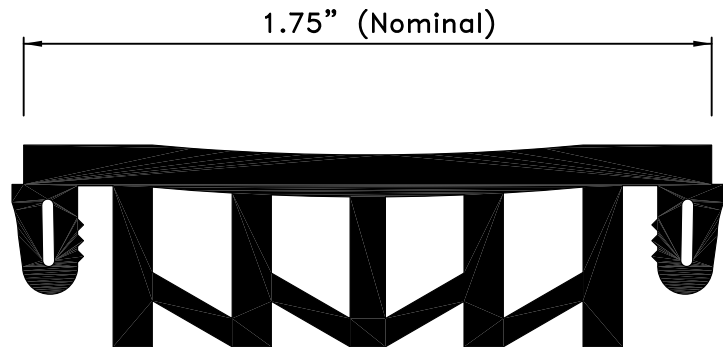

**ELCFC-200/200W**

Seal Part Number				
Model	Black Seal	White Seal	Grey Seal	Beige Seal
ELCFC-100/100W	28001	28002	28003	28004
ELCFC-200/200W	28005	28006	28007	28008

# Installation Procedure

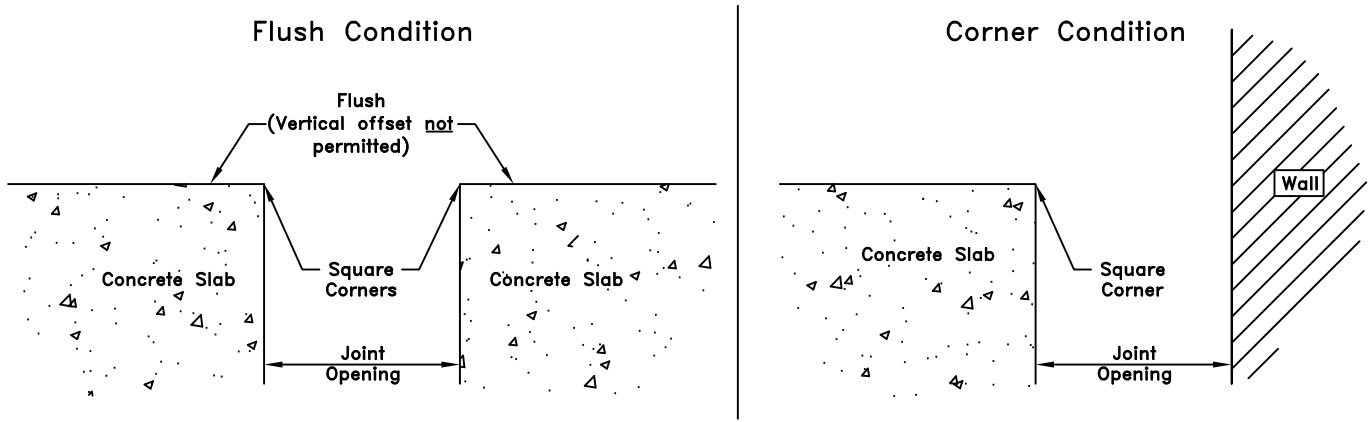

**1** Prior to beginning work, installer shall inspect corners of concrete slab for acceptability. For repair (if required) refer to step 2, also, measure joint opening for proper size as called for on shop drawings or cad detail.

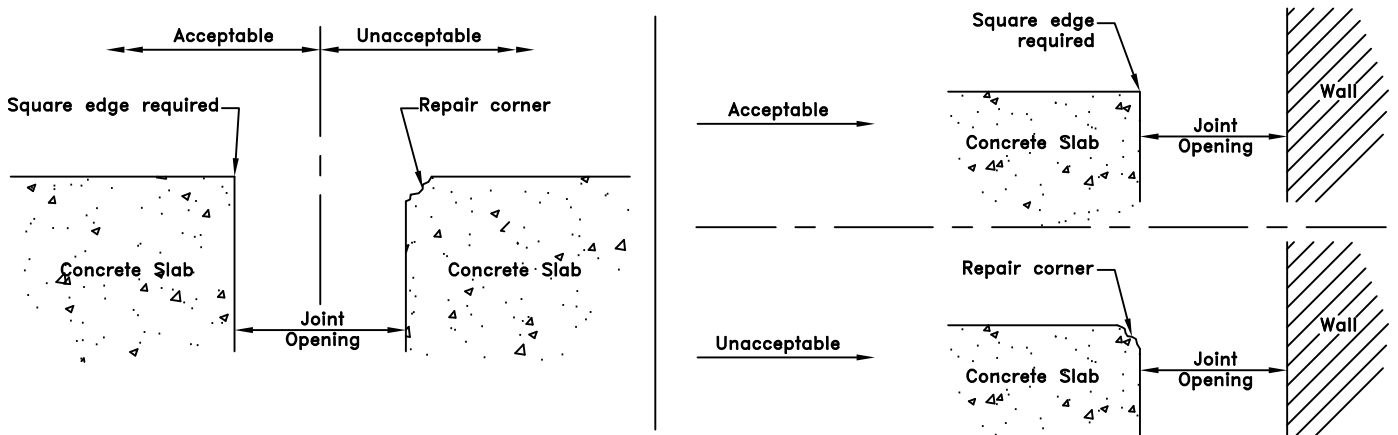

**2** Repair corner of concrete slab following manufacturers instructions.

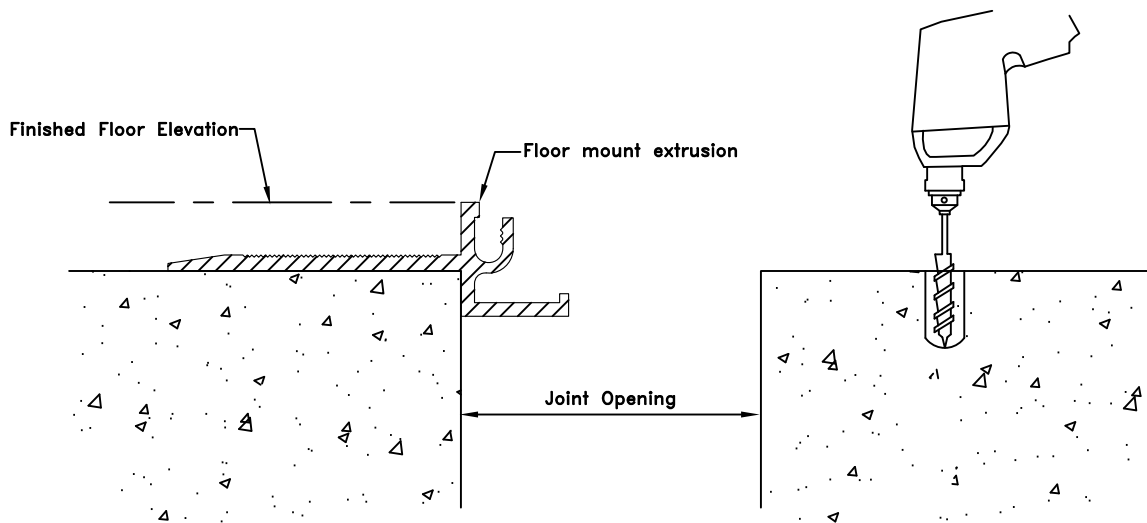

**3** Position aluminum extrusions on both sides of joint opening. Use 2" section of seal on both ends of extrusion as gauge to ensure proper separation. Mark hole locations and drill for #12 spax anchors.

**Note A:**  
Opening between aluminum extrusions must be set accurately to ensure seals proper installation.

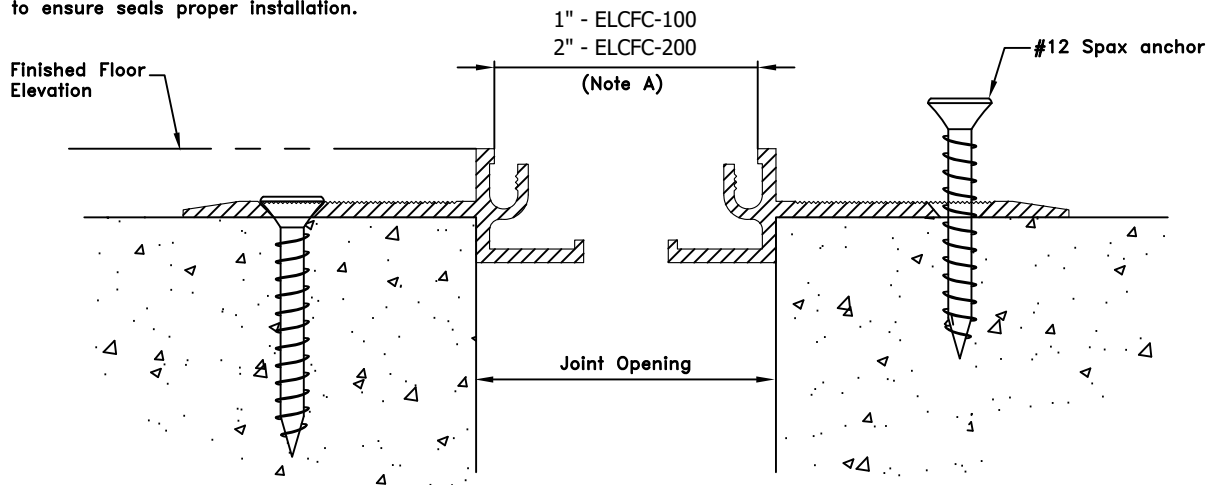

**4** Mount and secure extrusions to slab with #12 spax anchors.

### Corner Condition

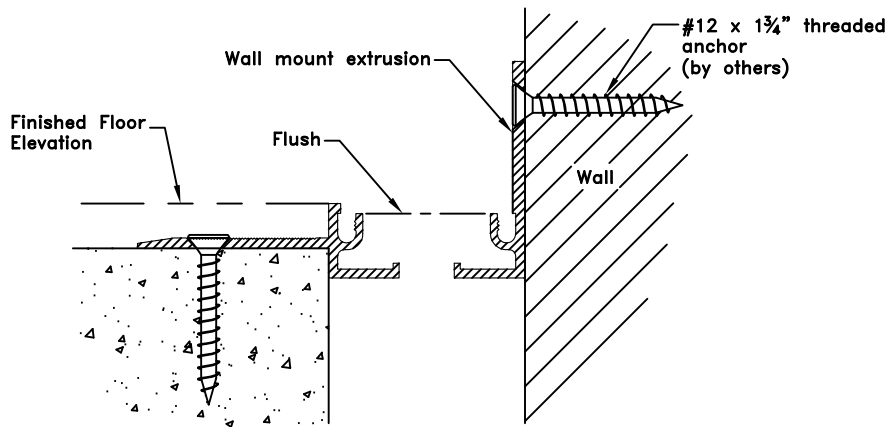

**4A** Secure extrusion to slab by using #12 spax anchor. Use 2" section of seal on both ends of extrusion as gauge to ensure proper separation. Along corner condition use screw anchor to mount wall extrusion to wall (supplied by others).

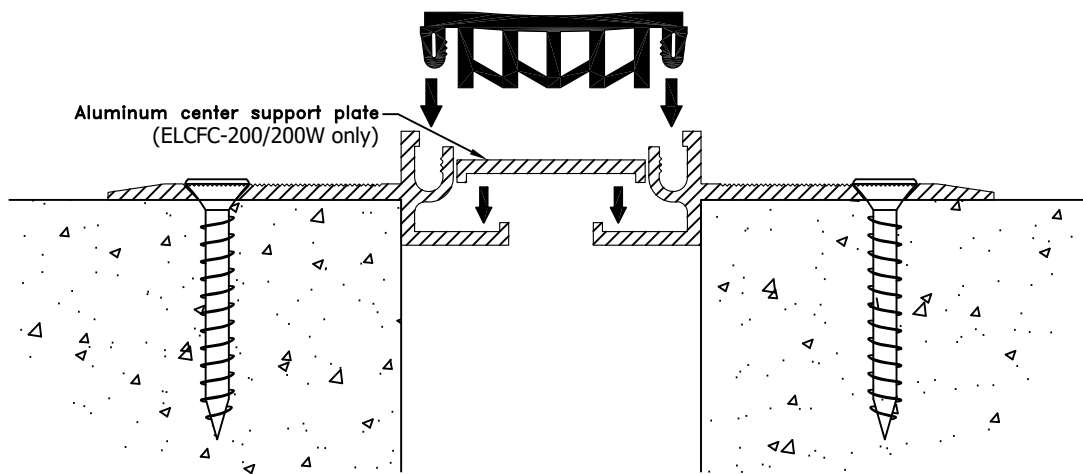

**5** Squeeze or slide elastomeric seal into aluminum extrusion.

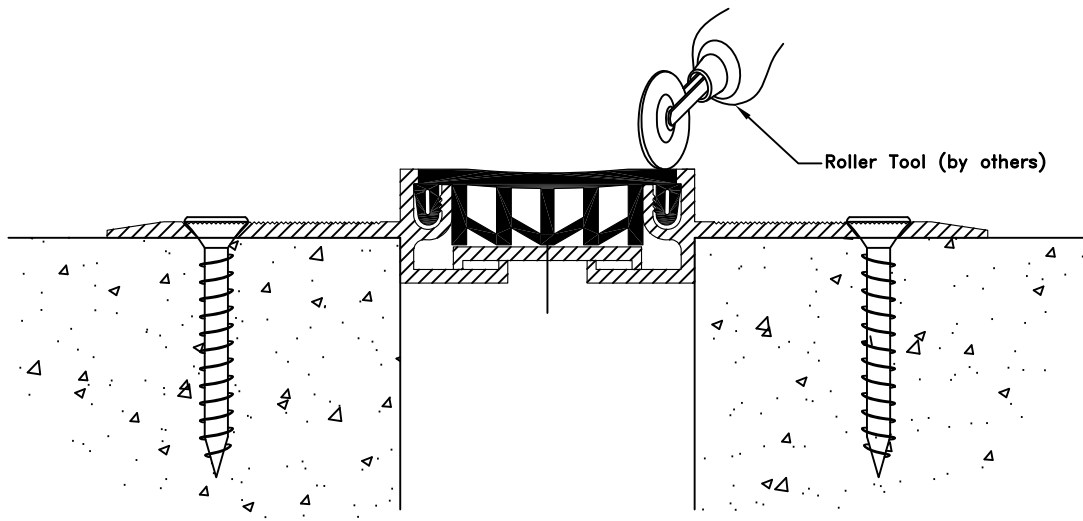

**6** Utilizing roller tool apply pressure directly over locking lug to ensure proper engagement of seal lug.

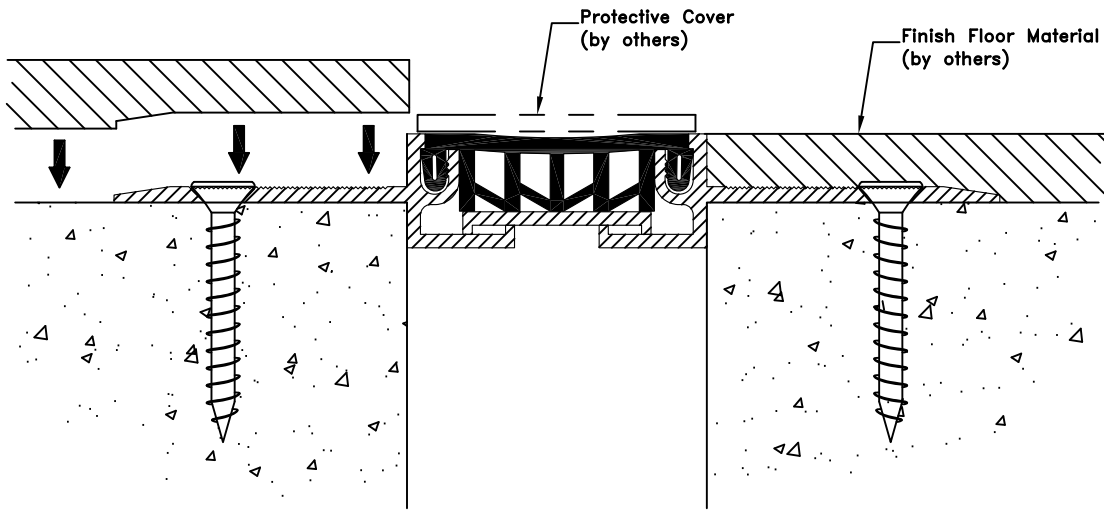

**7** Following manufacturers installation procedures install finish flooring materials. Ensure Flush installation with top of expansion joint system.  
**Note:** Protect expansion joint finish during installation of finish flooring materials. Also keep protection on expansion joint system during construction activities.

# Suggested Field Splice Procedure

1. Cut ends of seal with a sharp knife and miter box to the desired angle. Insure that cuts are clean and straight.
2. Clean ends of seal with a solvent.
3. Apply SI 750 Adhesive to one of the two seal ends to be bonded.
4. Apply pressure bringing the two surfaces into tight contact immediately after adhesive is applied. Hold in place for one to two minutes for initial bond.
5. Re-Check quality of all splices/miters and apply adhesive as required.
7. It is usually recommended to allow 15 minutes prior to installing seal. To achieve proper working strength care shall be exercised as a result that it takes 24 hours for adhesive to fully cure.

