

ELCFT-Series Installation Instructions

ELASTOMERIC SYSTEM – TILE

MODEL(S): ELCFT/ELCFTw

ELCFT Floor to Floor Cover System

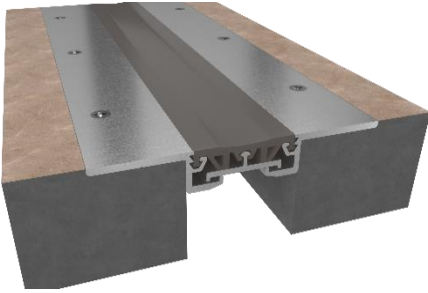

GENERAL DESCRIPTION

The ELCFT system is designed to be mounted directly over the joint openings for tile applications. The flooring mounts flush to the edge of the assembly.

GENERAL SAFETY PRECAUTIONS Improper selection, installation, or use can cause personal injury or property damage. It is solely the responsibility of the user, through their own analysis, to select products suitable to the specific application requirements, ensure proper maintenance and use as intended. Follow local, state, and federal regulations for proper installation and operation requirements.

Introduction + Safety

Please read the complete instructions carefully before beginning any work. To ensure proper installation and performance of the product, the following actions must be completed by the installing contractor. Failure to do so will affect product warranty.

Transportation + Storage

- Inspect all shipments and materials for missing or damaged components and hardware.
- Material must be stored in a clean, dry location.

Preparation

- Locate the packing slip(s) and/or shop drawings.
- Verify that all products listed on the packing slip are included in the package.
- Check the products for damage. If products are damaged, report a freight claim immediately and leave the products in their packaging. If you sign for products without reporting damage, you waive your right to a freight claim and will be responsible for their replacement cost.
- Read the instructions thoroughly before beginning installation.



Tool List

- Tape measure
- Phillips
- Hex screwdriver
- Slotted Drivers for Anchors
- Levels
- Awls
- Masking tape
- Rubber mallet
- Wooden block
- Trowel
- Chop saw to cut product to length
- Electric drill with 5/32” masonry bit
- Broom & dustpan or vacuum
- Adhesive glue

Included with the expansion joint system:

- 3/16” x 1-3/4” Tapcon fastener

Preinstallation

1. Ensure that the area where the expansion joint system is being installed is smooth and level. High spots should be ground down and low spots filled in.

INSTALLATION

1. Position base member frames in expansion joint per shop drawings. Using the frames as a template, mark and drill 3/16” holes in the concrete. Install base member frames with supplied Tapcon fasteners, making sure not to over tighten. **See Figure 1**

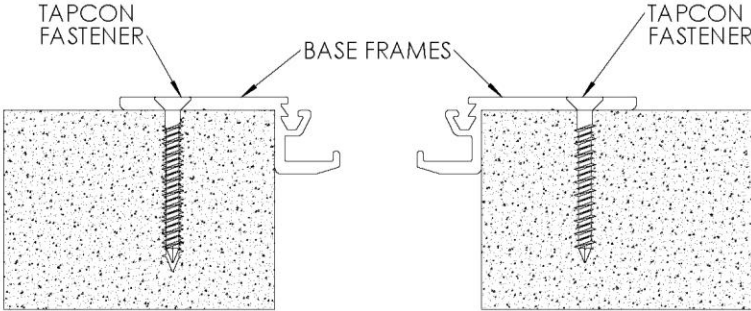

FIGURE 1



- 2. Place slide plate (not required on 1” joint sizes) in the lower channels of the base frames with the bent ends of the plate pointing downwards. **See Figure 2**

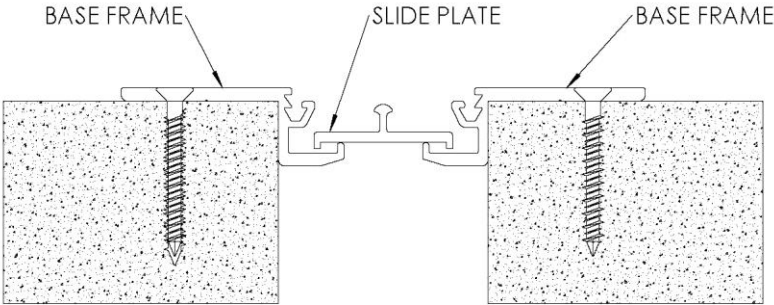

FIGURE 2

- 3. Position the elastomeric seal into position and push the seal bulbs into the base frame top channels as shown. Make sure the bulbs are seated all the way into the channel. Also, make sure the bottom center channel in the seal is pushed over the protrusion on the slide plate (not required on 1” joint sizes). **See Figure 3**

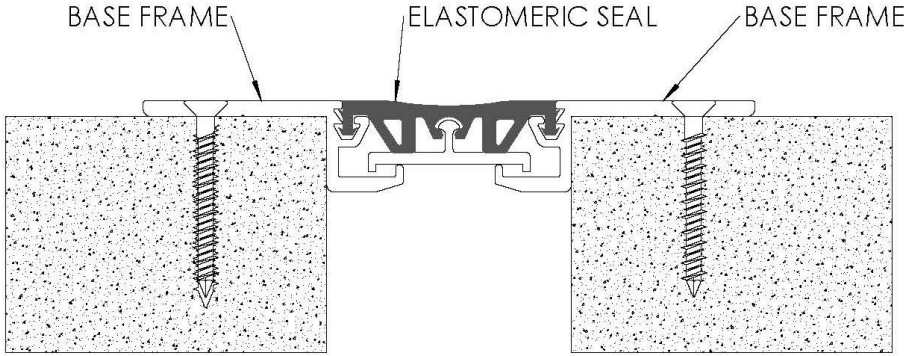

FIGURE 3

- 4. Finished tile floor (by others) may now be installed. **See Figure 4**

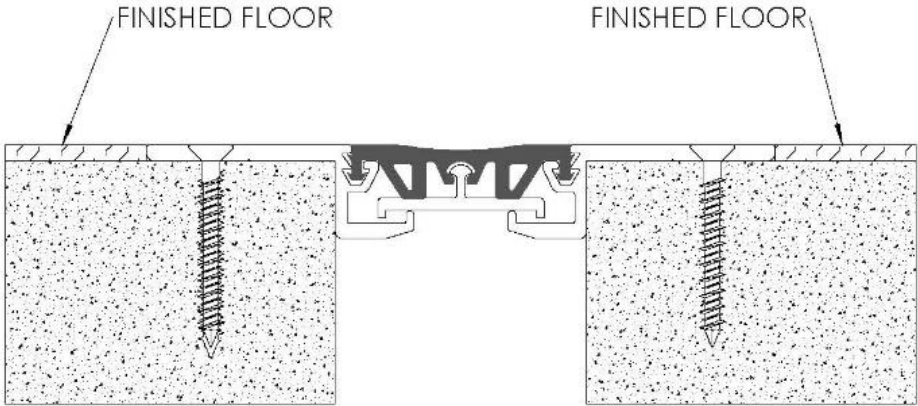

FIGURE 4

Interior Joints (Floor)



ELCFTw Floor to Wall Cover System

Interior Joints (Floor)

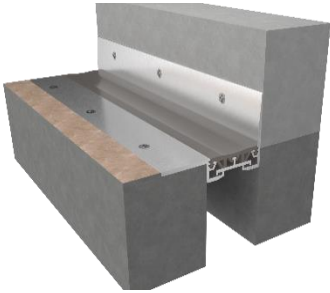

GENERAL DESCRIPTION

EMS' ELCFTw Interior Cover System is designed to match the ELCFT cover plate in floor to wall applications.

Included with the expansion joint system:

- 3/16" x 1-3/4" Tapcon fastener

Pre-Installation

1. Ensure that the area where the expansion joint system is being installed is smooth and level. High spots should be ground down and low spots filled in.

INSTALLATION

1. Position base member frame in expansion joint per shop drawings. Using the frame as a template, mark and drill 3/16" holes in the concrete. Install base member frame with supplied Tapcon fasteners, making sure not to over tighten. **See Figure 1**

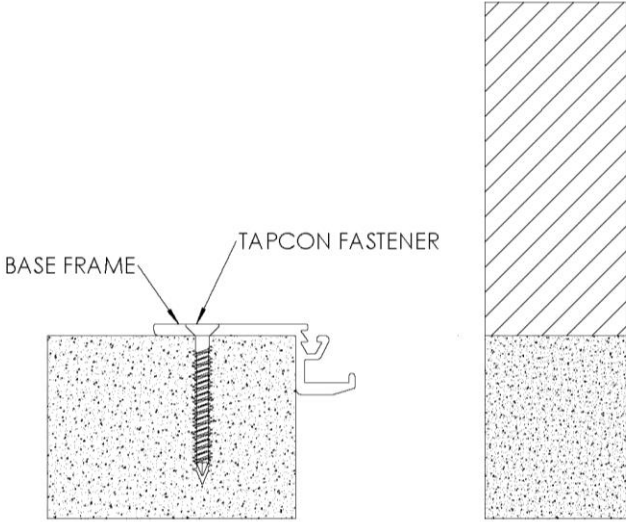

FIGURE 1



- 2. Position the wall frame into position, making sure the top channel is level with the top channel of the base frame. Attach the wall frame to the wall with appropriate fasteners (by others) for the wall type 18” o.c. **See Figure 2**

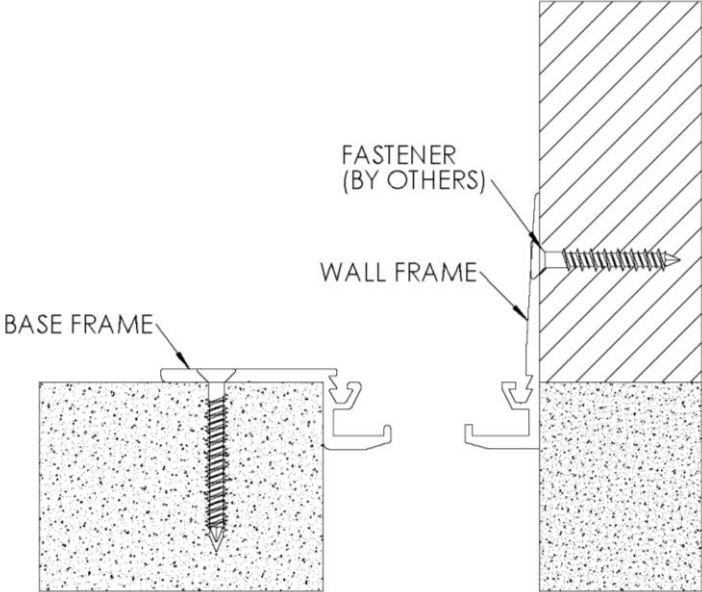

FIGURE 2

- 3. Place slide plate (not required on 1” joint sizes) in the lower channel of the base frame and wall frame with the bent ends of the plate pointing downwards. **See Figure 3**

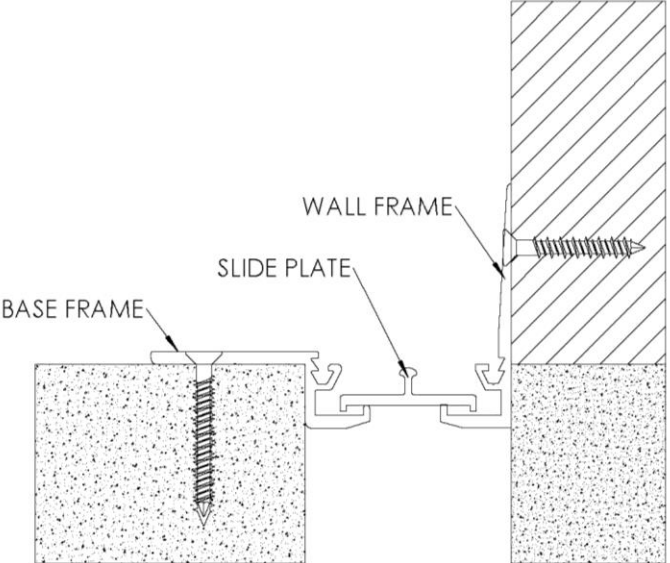

FIGURE 3

Interior Joints (Floor)



Interior Joints (Floor)

- 4. Position the elastomeric seal into position and push the seal bulbs into the base frame and wall frame top channels as shown. Make sure the bulbs are seated all the way into the channel. Also, make sure the bottom center channel in the seal is pushed over the protrusion on the slide plate (not required on 1” joint sizes). **See Figure 4**

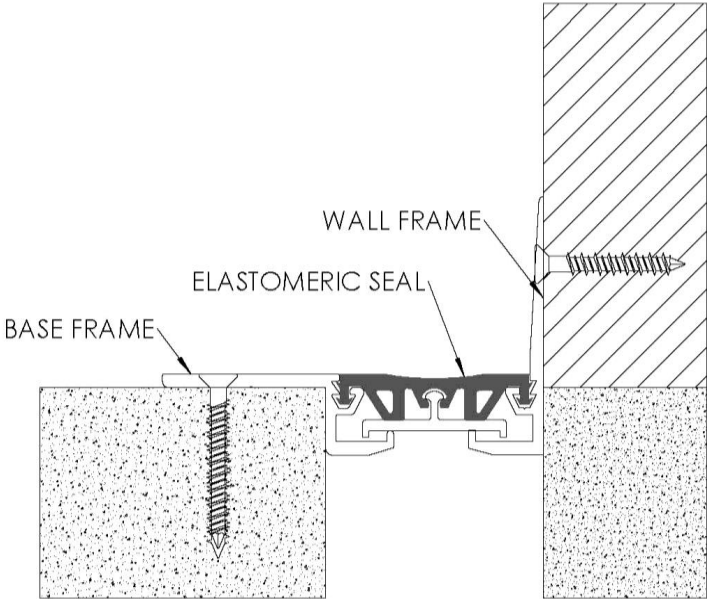

FIGURE 4

- 5. Finished tile floor (by others) may now be installed. **See Figure 5**

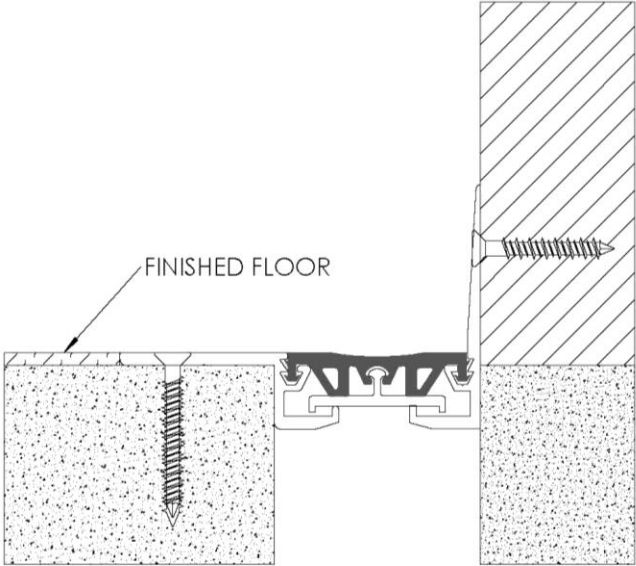

FIGURE 5



FIELD SPLICE FOR FLAT ELASTOMERIC SEAL

1. Determine the angle needed and cut ends of seal in a miter box with a sharp, non-serrated knife. **See Figure 1**

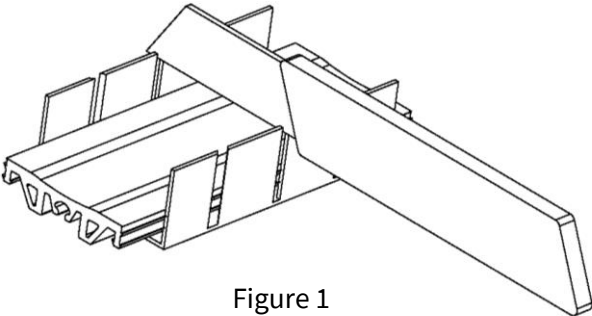

Figure 1

2. Using a solvent (by others) that is safe for elastomeric materials clean the ends of the seals. **See Figure 2**

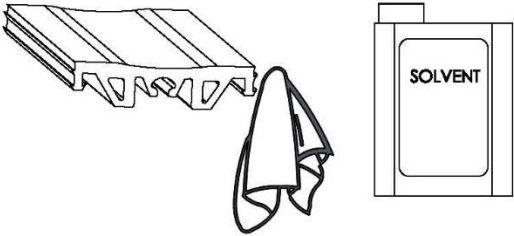

Figure 2

3. Apply a Super Glue, cyanoacrylate type (non-gel) or similar adhesive (by others) and follow instructions by the adhesive manufacturer. **See Figure 3**

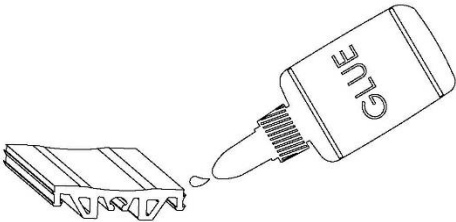

Figure 3

Interior Joints (Floor)



4. Check the splices after the adhesive has cured and reapply adhesive as necessary. Allow 15 minutes prior to installing seal. It typically takes 24 hours for adhesive to fully cure and achieve proper working strength. Ensure that the splice of the seal is not within 2” of a joint in the aluminum extrusion. **See Figure 4**

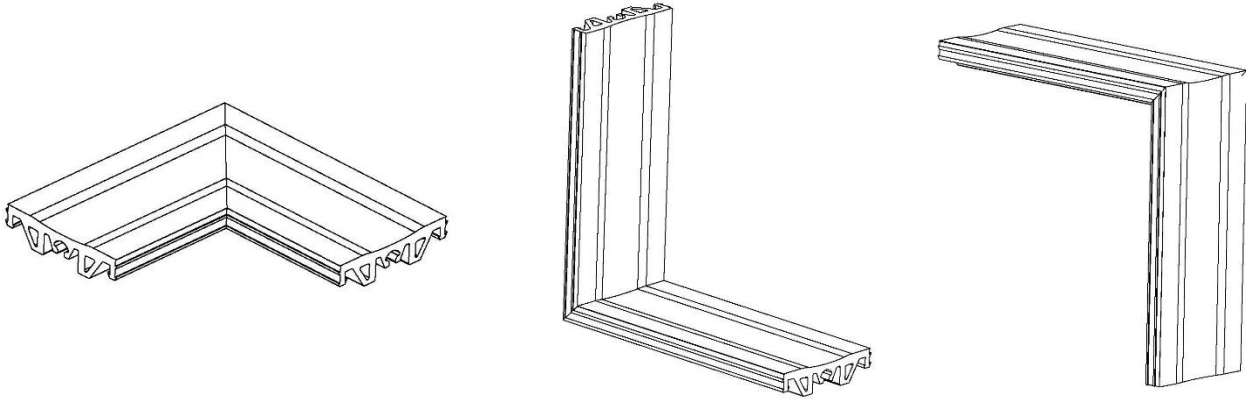

Figure 4

Interior Joints (Floor)