

EWJ-Series Installation Instructions

SEISMIC ELASTOMERIC WALL & CEILING SYSTEM – EXTERIOR RECESSED APPLICATION

Model(s): EWJ/EWJw

EWJ Wall to Wall / Ceiling to Ceiling Cover System – 2” Through 6” Sizes

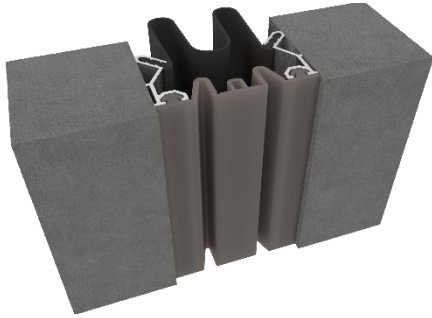

GENERAL DESCRIPTION

This Elastomeric Exterior Wall System is a weather resistant system that accommodates thermal and seismic movement. The visual seal matches many exterior building colors, and the rear moisture barrier prevents exterior moisture or condensation from entering the wall cavity.

Introduction + Safety

GENERAL SAFETY PRECAUTIONS Improper selection, installation, or use can cause personal injury or property damage. It is solely the responsibility of the user, through their own analysis, to select products suitable to the specific application requirements, ensure proper maintenance and use as intended. Follow local, state, and federal regulations for proper installation and operation requirements.

Please read the complete instructions carefully before beginning any work. To ensure proper installation and performance of the product, the following actions must be completed by the installing contractor. Failure to do so will affect product warranty.

Transportation + Storage

- Inspect all shipments and materials for missing or damaged components and hardware.
- Material must be stored in a clean, dry location.

Preparation

- Locate the packing slip(s) and shop drawings.
- Verify that all products listed on the packing slip are included in the package.
- Check the products for damage. If products are damaged, report a freight claim immediately and leave the products in their packaging. If you sign for products without reporting damage, you waive your right to a freight claim and will be responsible for replacement cost.
- Read the instructions thoroughly before beginning installation.



Tool List

- Tape measure
- Chop saw to cut product to length
- Electric drill with 5/32" masonry bit & 3/16" metal bit
- Utility knife
- Sealant
- Structural adhesive
- Wood blocking

Included with the expansion joint system:

Ø3/16" X 1-3/4" Tapcon fasteners

Preinstallation

1. Ensure that the area where the expansion system is being installed is smooth and level.

INSTALLATION

1. Position aluminum extrusion in the expansion joint and mark hole locations at 18" OC. Drill Ø3/16" holes into the extrusions at the marked locations. When attaching to a concrete wall, drill a hole into the concrete at these locations with a Ø5/32" masonry bit. Repeat on the other side. **See Figure 1.**

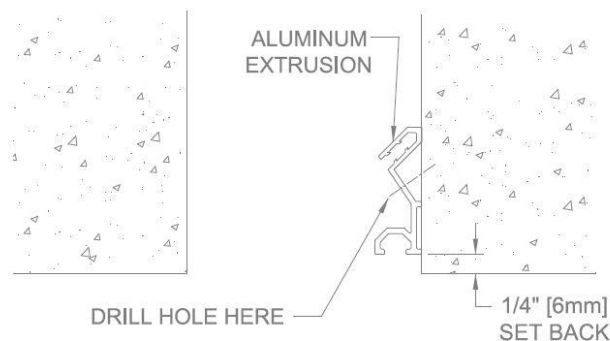

FIGURE 1



2. Apply a bead of sealant (by others) into the channel in the extrusion as shown. Attach the aluminum extrusions to the concrete wall using $\text{Ø}3/16$ " Tapcon anchors. For other substrates, use appropriate fasteners and methods. Extrusions should be flush to substrate to ensure a weathertight seal. **See Figure 2.**

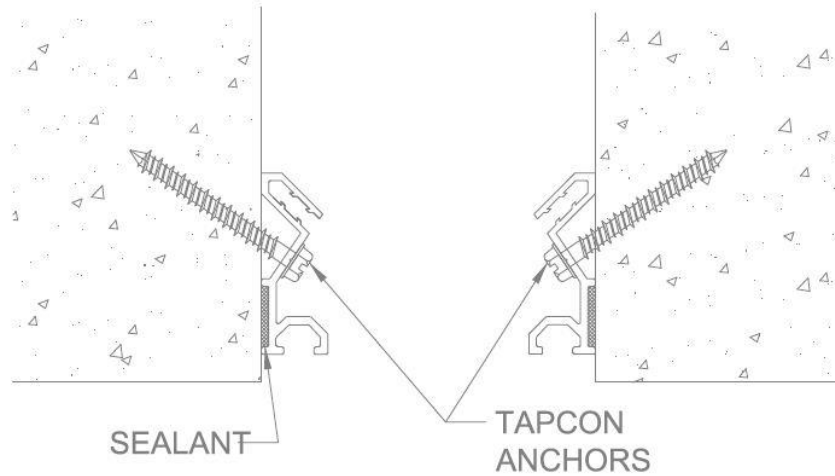

FIGURE 2

3. Apply a bead of sealant (by others) into the back channels of the extrusions. Install the back seal into these channels of the extrusion as shown. Make sure the bulbs of the back seal are firmly seated into the channels of the extrusion. **See Figure 3.**

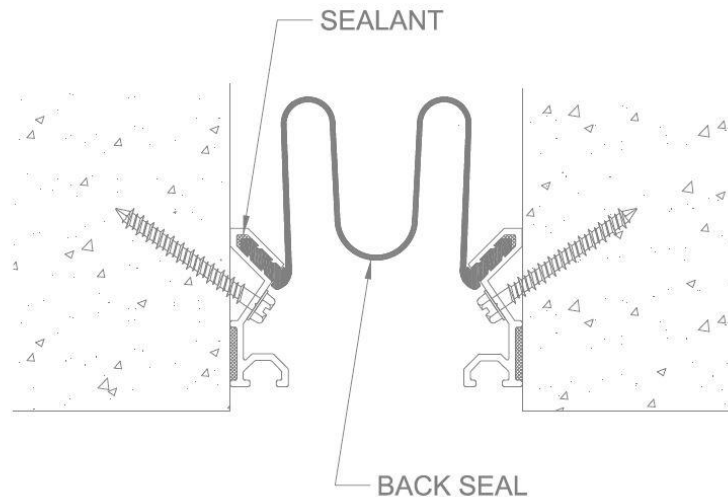

FIGURE 3

4. Position the elastomeric face seal into position and push the seals bulbs into the extrusion channels as shown. Make sure the bulbs are seated all the way into the channel. Do not stretch the seal lengthwise during installation. **See Figure 4.**

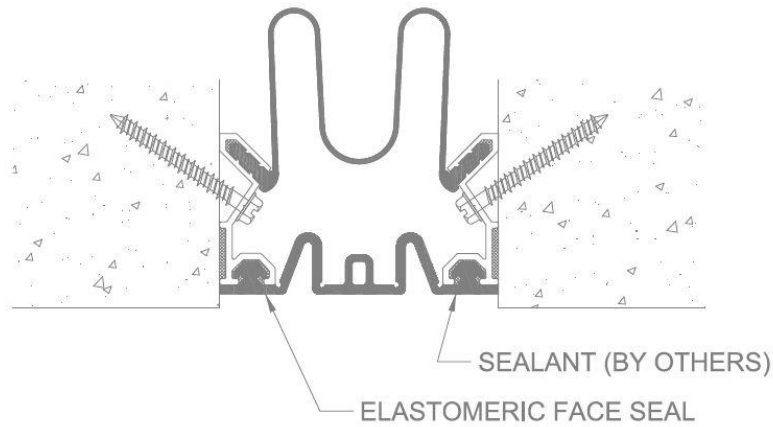
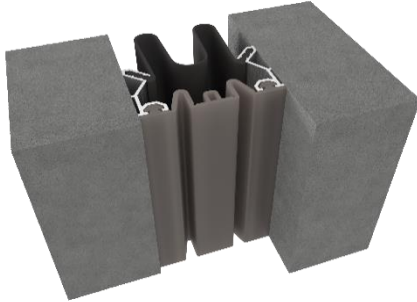

FIGURE 4

EWJw Wall to Corner System – 2” Through 4” Sizes



GENERAL DESCRIPTION

EMS' EWJw Elastomeric Exterior Wall System is designed to match the EWJ system in corner applications.

Preinstallation

1. Ensure that the area where the expansion system is being installed is smooth and level.

INSTALLATION

1. Position one of the frames onto the wall of the expansion joint and mark hole locations at 18” OC. (Reference shop drawings for more details) Drill $\text{Ø}3/16$ ” holes into the extrusions at the marked locations. When attaching to a concrete wall, drill a hole into the concrete at these locations with a $\text{Ø}5/32$ ” masonry bit. **See Figure 1**

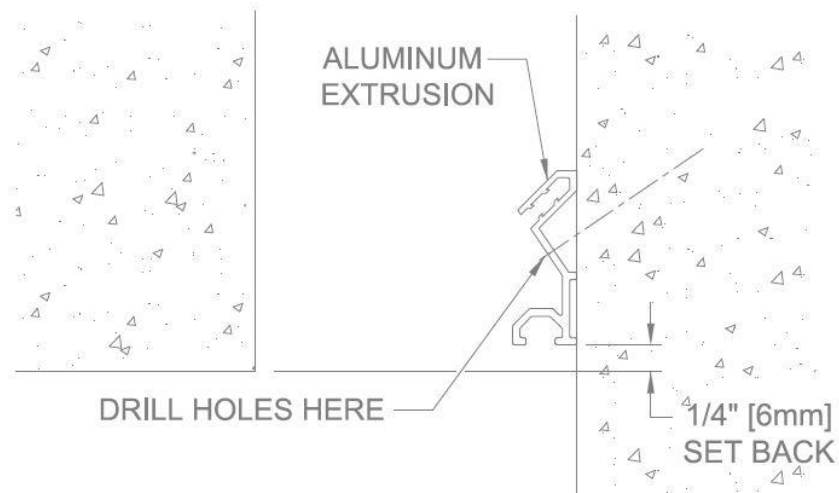

FIGURE 1

2. Apply a bead of sealant (by others) into the wall extrusion channel as shown. Attach the aluminum extrusions to the concrete wall using $\text{Ø}3/16$ " Tapcon anchors. For other substrates, use appropriate fasteners and methods. Extrusion should be flush to substrate to ensure a weathertight seal. **See Figure 2.**

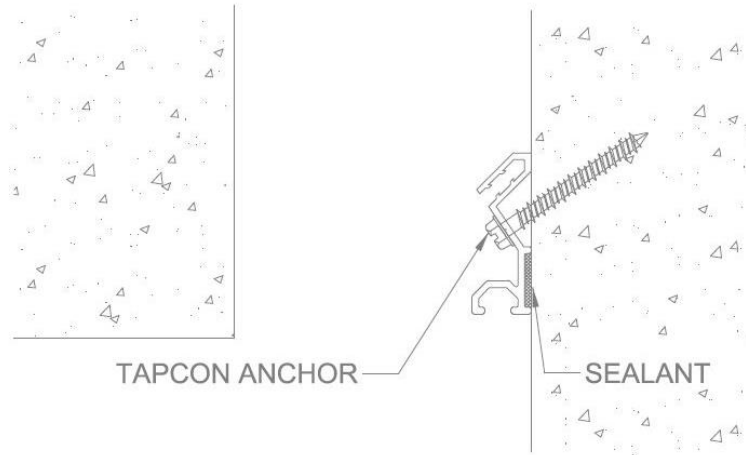

FIGURE 2

3. Apply structural adhesive (by installer) along the back side of the other extrusions prior to installation. (Follow adhesive manufacturer's guidelines) Mount the extrusion to the inside surface as shown, making sure it lines up with the wall extrusion. Extrusions should be flush to substrate to ensure a weathertight seal. (Also refer to shop drawings for more detail). **See Figure 3.**

Helpful Hint: Install temporary wood blocking to secure extrusion to wall while adhesive cures.

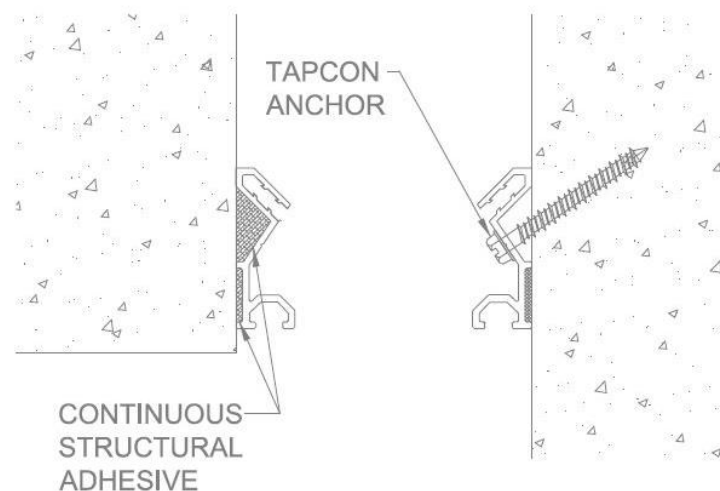

FIGURE 3



4. Before installing moisture barrier, apply sealant (by others) to the rear locking cavities of the aluminum. Position the moisture barrier and push the bulbs into the rear channel as shown.

See figure 4.

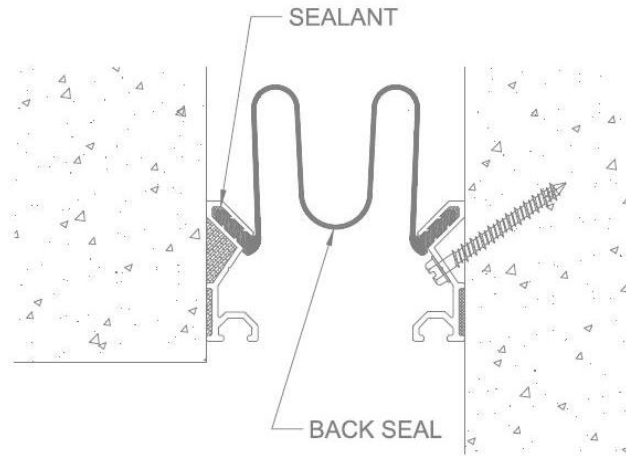

FIGURE 4

5. Repeat these instructions when installing the face seal. Make sure the bulbs are seated all the way into the channel. Do not stretch the seal lengthwise during installation. **See Figure 5.**

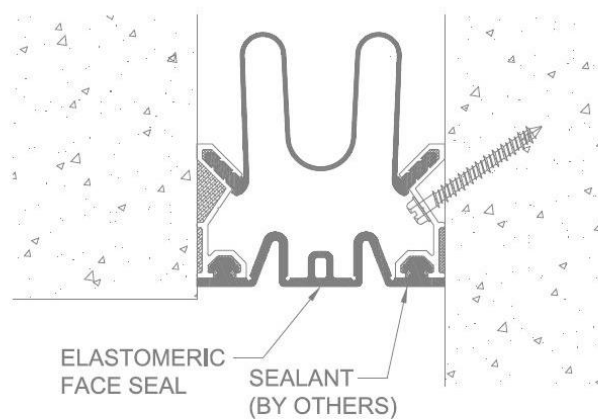

FIGURE 5

FIELD SPLICE FOR ELASTOMERIC V-SEAL

1. After determining the angle needed, use a miter box and a non-serrated saw (teeth removed) to cut ends of seal clean, straight and square. **See Figure 1**

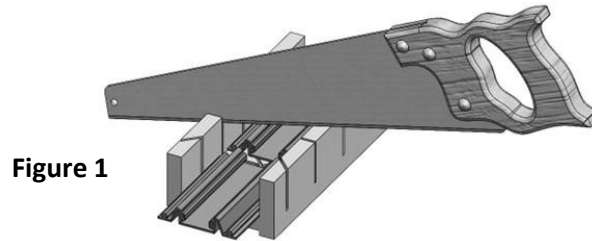

Figure 1

2. After donning the proper PPE, use a solvent (by others) that is safe for elastomeric materials and clean any residual material from the cut ends of the seals. Allow to dry prior to Step #3.

See Figure 2

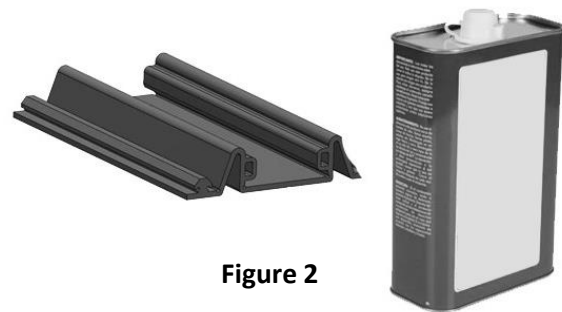

Figure 2

Straight Butt Splice

Insert splice clips (if required) (part # 27511) halfway into the alignment holes on one of the seals. Apply glue, cyanoacrylate or similar adhesive (by others) to both seal ends and follow instructions by the adhesive manufacturer. Almost immediately after adhesive is applied, insert the protruding

ends of the splice clips into the ends of the two seals together, applying uniform pressure for at least two minutes while maintaining contact between both sides. The splice clip is not necessary, but is recommended, especially on larger sized seals. **See Figure 3**

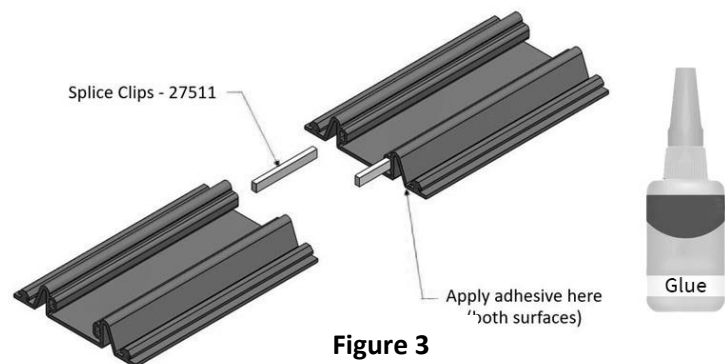

Figure 3

Vertical Outside Splice

Insert splice clips (if required) (part # 28090) halfway into the alignment holes on one of the seals. Apply glue, cyanoacrylate or similar adhesive (by others) to both seal ends and follow instructions by the adhesive manufacturer. Almost immediately after adhesive is applied, insert the protruding ends of the splice clips into the ends of the two seals together, applying uniform pressure for at least two minutes while maintaining contact between both sides. The splice clip is not necessary, but is recommended, especially on larger sized seals. **See Figure 4**

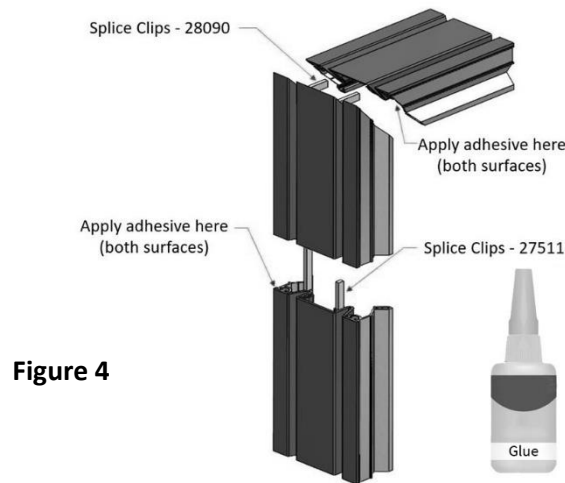

Figure 4

Vertical Inside Splice

Insert splice clips (if required) (part # 28090) halfway into the alignment holes on one of the seals. Apply glue, cyanoacrylate or similar adhesive (by others) to both seal ends and follow instructions by the adhesive manufacturer. Almost immediately after adhesive is applied, insert the protruding ends of the splice clips into the ends of the two seals together, applying uniform pressure for at least two minutes while maintaining contact between both sides. The splice clip is not necessary, but is recommended, especially on larger sized seals. **See Figure 5**

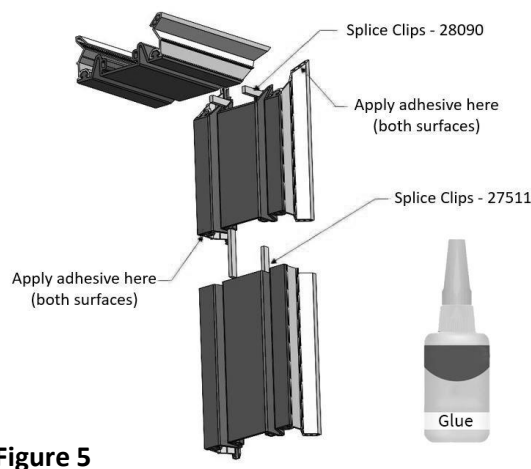

Figure 5

See Figure 5

Horizontal Splice

Insert splice clips (if required) (part # 28091) halfway into the alignment holes on one of the seals. Apply glue, cyanoacrylate or similar adhesive (by others) to both seal ends and follow instructions by the adhesive manufacturer. Almost immediately after adhesive is applied, insert the protruding ends of the splice clips into the ends of the two seals together, applying uniform pressure for at least two minutes while maintaining contact between both sides. The splice clip is not necessary, but is recommended, especially on larger sized seals. **See Figure 6**

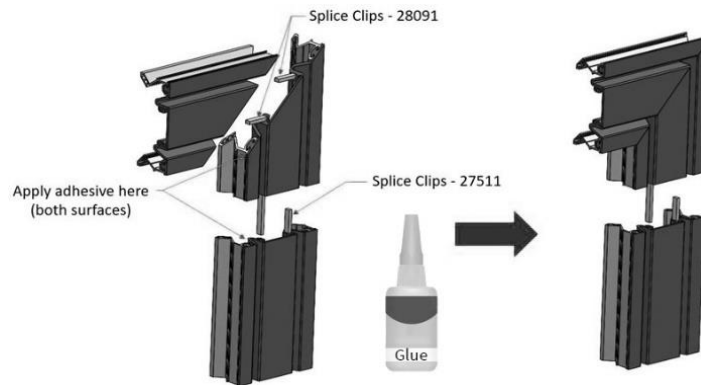

Figure 6

3. Recheck the splices after the adhesive has cured and reapply adhesive as necessary. Allow 15 minutes prior to installation of seal. Allow 24 hours for adhesive to fully cure and achieve proper working strength. Ensure that the splice of the seal is not within 2" of a joint in the aluminum extrusion, if possible.

See Figure 7



Figure 7

4. EMS recommends the use of a “termination boot” at the base of the EWJ Expansion Joint System to aid in removing any moisture that may accumulate between the Visual Seal and Moisture Barrier. This component should be in place prior to the EJ System installation.

Note: Termination Boot can be made of Elastomeric Sheet Good found on the jobsite, but the Boot must be created to accommodate the minimum and maximum movement criteria of the specific system being installed. Boot must also be watertight.

