



# SUBSTITUTION REQUEST

(After the Bidding/Negotiating Phase)

Project: \_\_\_\_\_ Substitution Request Number: \_\_\_\_\_  
 \_\_\_\_\_  
 From: \_\_\_\_\_  
 To: \_\_\_\_\_ Date: \_\_\_\_\_  
 \_\_\_\_\_  
 A/E Project Number: \_\_\_\_\_  
 Re: \_\_\_\_\_ Contract For: \_\_\_\_\_

Specification Title: \_\_\_\_\_ Description: \_\_\_\_\_  
 Section: \_\_\_\_\_ Page: \_\_\_\_\_ Article/Paragraph: \_\_\_\_\_

Proposed Substitution: \_\_\_\_\_  
 Manufacturer: \_\_\_\_\_ Phone: \_\_\_\_\_  
 Address: \_\_\_\_\_  
 Trade Name: \_\_\_\_\_ Model No.: \_\_\_\_\_  
 Installer: \_\_\_\_\_ Phone: \_\_\_\_\_  
 Address: \_\_\_\_\_

History:  New product  1-4 years old  5-10 years old  More than 10 years old

Differences between proposed substitution and specified product: \_\_\_\_\_  
 \_\_\_\_\_  
 \_\_\_\_\_

Point-by-point comparative data attached — REQUIRED BY A/E

Reason for not providing specified item: \_\_\_\_\_  
 \_\_\_\_\_

Similar Installation:

Project: \_\_\_\_\_ Architect: \_\_\_\_\_  
 Address: \_\_\_\_\_ Owner: \_\_\_\_\_  
 \_\_\_\_\_ Date Installed: \_\_\_\_\_

Proposed substitution affects other parts of Work:  No  Yes; explain \_\_\_\_\_

Savings to Owner for accepting substitution: \_\_\_\_\_ (\$ \_\_\_\_\_).

Proposed substitution changes Contract Time:  No  Yes [Add] [Deduct] \_\_\_\_\_ days.

Supporting Data Attached:  Drawings  Product Data  Samples  Tests  Reports  \_\_\_\_\_

# SUBSTITUTION REQUEST

(After the Bidding/Negotiating Phase — Continued)

---

The Undersigned certifies:

- Proposed substitution has been fully investigated and determined to be equal or superior in all respects to specified product.
  - Same warranty will be furnished for proposed substitution as for specified product.
  - Same maintenance service and source of replacement parts, as applicable, is available.
  - Proposed substitution will have no adverse effect on other trades and will not affect or delay progress schedule.
  - Cost data as stated above is complete. Claims for additional costs related to accepted substitution which may subsequently become apparent are to be waived.
  - Proposed substitution does not affect dimensions and functional clearances.
  - Payment will be made for changes to building design, including A/E design, detailing, and construction costs caused by the substitution.
  - Coordination, installation, and changes in the Work as necessary for accepted substitution will be complete in all respects.
- 

Submitted by: \_\_\_\_\_

Signed by: \_\_\_\_\_

Firm: \_\_\_\_\_

Address: \_\_\_\_\_

Telephone: \_\_\_\_\_

Attachments:

---

## A/E's REVIEW AND ACTION

- Substitution approved - Make submittals in accordance with Specification Section 01 25 00 Substitution Procedures.
- Substitution approved as noted - Make submittals in accordance with Specification Section 01 25 00 Substitution Procedures.
- Substitution rejected - Use specified materials.
- Substitution Request received too late - Use specified materials.

Signed by: \_\_\_\_\_ Date: \_\_\_\_\_

---

Additional Comments:  Contractor  Subcontractor  Supplier  Manufacturer  A/E  
 Other:

# ESFB Series - Renovation Application

The Renovation Seismic Expansion Joint System is designed for renovation building projects where an expansion joint is needed to tie new construction to existing construction. The system is bolted into the existing construction and a block out with back fill is necessary for the new construction.

## FEATURES

**SEISMIC TECHNOLOGY** The cover plate stays centered over openings before, during and after a seismic event with the use of the seismic centering bar.

**ADA COMPLIANT** Heavy-pedestrian traffic requirements are met while maintaining a smooth ADA compliant transition.

## DETAILS

### MATERIAL

6063-T5 Aluminum, Meets ASTB B221

6061-T6 Aluminum, Meets ASTB B209

5052-H32 Aluminum, Meets ASTM B209

**FINISH** Mill

### MOVEMENT

- Thermal: Horizontal and Vertical
- Seismic: Lateral Shear

**MOUNTING** Block Out and Surface Mount

**JOINT SIZE** 1 inch to 12 inches

**LENGTH** 10 Linear Feet

**APPLICATION** Interior

**LOAD** Pedestrian and Light Cart

**INSTALLATION** Floor

**OPTIONS** Moisture Barrier, Fire Barrier

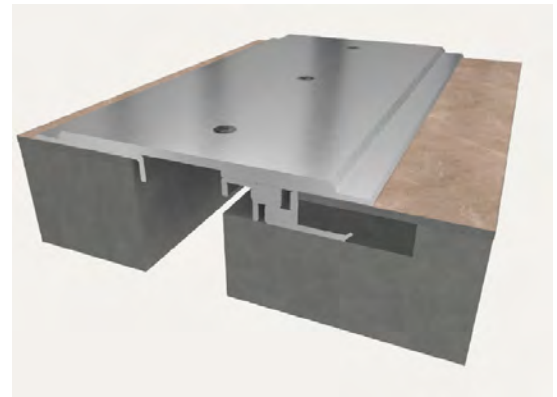

## FLOOR-TO-FLOOR

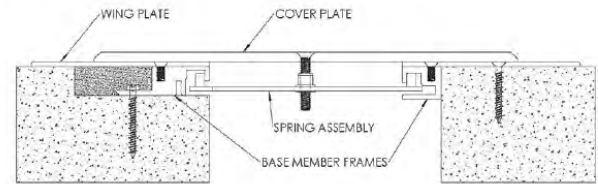

## FLOOR-TO-WALL-CORNER

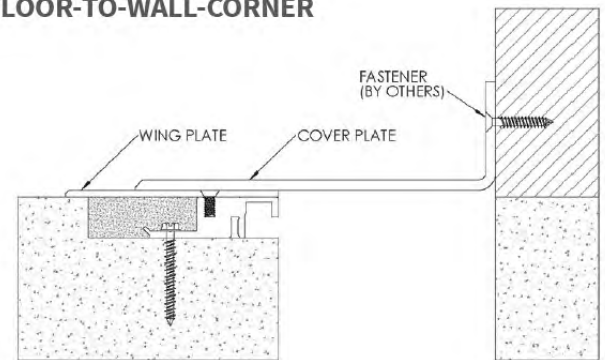

MODELS	MODEL	APPLICATION	JOINT SIZE AT MEAN T°F	EXPOSED SIGHT LINE	TOTAL MOVEMENT
	ESFB-200	Floor to Existing Floor	2" (51mm)	7.25" (184mm)	2" (51mm)
	ESFB-400	Floor to Existing Floor	4" (102mm)	11" (279mm)	4" (102mm)
	ESFB-600	Floor to Existing Floor	6" (152mm)	14.25" (362mm)	6" (152mm)
	ESFB-800	Floor to Existing Floor	8" (203mm)	17.75" (451mm)	8" (203mm)
	ESFB-1000	Floor to Existing Floor	10" (254mm)	21.25" (539mm)	10" (254mm)
	ESFB-1200	Floor to Existing Floor	12" (305mm)	25.25" (641mm)	12" (305mm)
	ESFB-200W	Floor to Wall Corner	2" (51mm)	4.75" (121mm)	1" (25mm)
	ESFB-400W	Floor to Wall Corner	4" (102mm)	7.94" (201mm)	2" (51mm)
	ESFB-600W	Floor to Wall Corner	6" (152mm)	10.62" (270mm)	3" (76mm)
	ESFB-800W	Floor to Wall Corner	8" (203mm)	13.37" (340mm)	4" (102mm)
	ESFB-1000W	Floor to Wall Corner	10" (254mm)	16.12" (410mm)	5" (127mm)
	ESFB-1200W	Floor to Wall Corner	12" (305mm)	19.12" (486mm)	6" (152mm)



Erie Metal Specialties, Inc.  
13311 Main Road  
Akron, NY 14001

Phone: 716-542-3991  
Website: [www.eriemetal.com](http://www.eriemetal.com)  
E-Mail: [sales@eriemetal.com](mailto:sales@eriemetal.com)

# ESFB-Series Installation Instructions

## ARCHITECTURAL SEISMIC SYSTEM – RENOVATION

**MODEL(S): ESFB/ESFBw**

### ESFB Floor to Floor Cover System



#### GENERAL DESCRIPTION

The ESFB Renovation Seismic Expansion Joint System is designed for renovation building projects where an expansion joint is needed to tie new construction to existing construction. The system is bolted into the existing construction and a breakout is necessary for the new construction.

**GENERAL SAFETY PRECAUTIONS** Improper selection, installation, or use can cause personal injury or property damage. It is solely the responsibility of the user, through their own analysis, to select products suitable to the specific application requirements, ensure proper maintenance and use as intended. Follow local, state, and federal regulations for proper installation and operation requirements.

#### Introduction + Safety

Please read the complete instructions carefully before beginning any work. To ensure proper installation and performance of the product, the following actions must be completed by the installing contractor. Failure to do so will affect product warranty.

#### Transportation + Storage

- Inspect all shipments and materials for missing or damaged components and hardware.
- Material must be stored in a clean, dry location.

#### Preparation

- Locate the packing slip(s) and/or shop drawings.
- Verify that all products listed on the packing slip are included in the package.
- Check the products for damage. If products are damaged, report a freight claim immediately and leave the products in their packaging. If you sign for products without reporting damage, you waive your right to a freight claim and will be responsible for their replacement cost.
- Read the instructions thoroughly before beginning installation.



## Tool List

- Tape measure
- Chop saw to cut product to length
- Electric drill with 3/16” masonry bit
- Broom & dustpan or vacuum

## Included with the expansion joint system:

- 3/16” x 1-3/4” Tapcon fastener
- #10-24 screws

## Pre-Installation

1. Pour floors with blockouts as shown on shop drawings. The blockout should be a minimum of 2” wider than the exposed cover width by the specified depth.
2. Ensure that the blockout is smooth. High spots should be ground down and low spots filled in. Make sure the blockout is clean by sweeping and/or vacuuming.

## INSTALLATION

1. Remove the factory installed #10-24 screw that attaches the wing plate to the base member frame and retain for reinstallation later. **See Figure 1**

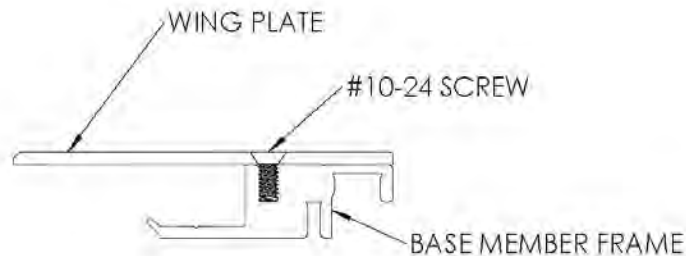

FIGURE 1

2. Position appropriate base member frame in blockout and position other base member frame on the non-blockout side per shop drawings. Using the frames as a template, mark and drill 3/16" holes for Tapcon fasteners. Install base member frames to the blockout opening and non-blockout side with fasteners, making sure not to over tighten. *Note: In the 2" size the base frame on the non-blockout side is shaped differently than what is shown in Figure 2, see shop drawing for clarification. See Figure 2*

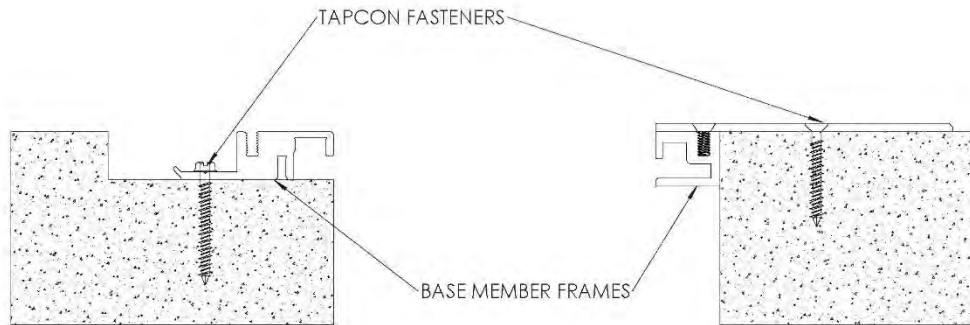

FIGURE 2

3. Protect the exposed surface of the expansion joint, then using an appropriate infill material, fill in the blockout level with the surrounding floor. **See Figure 3**

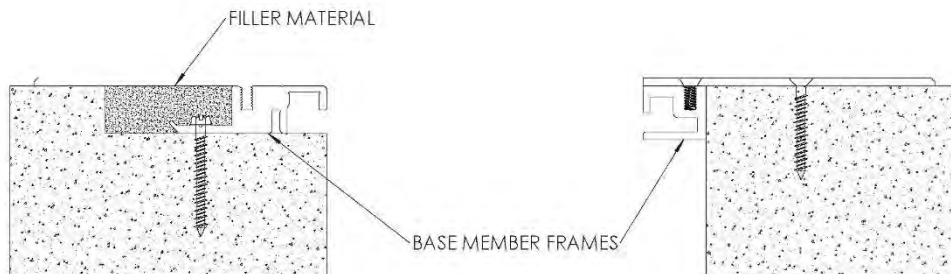

FIGURE 3

4. After infill material has cured, reinstall the wing plate to the base member frame with the #10-24 screw. **See Figure 4**

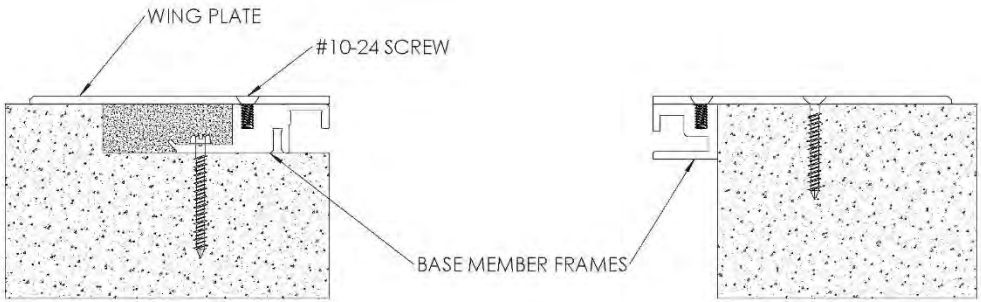

FIGURE 4

5. Lay cover plate over the left base frame with ends flush and mark the cover plate center holes onto the base frame near the inside edge. Repeat this on the right side. Position the spring assembly in the spring track on the base frames. This is done by sliding the spring assemblies in from the ends of the frames and aligning them with the marked locations. The spring assemblies will be diagonal to the opening. Tape may be needed to hold the spring assembly in place. *Note: In the 2" size the spring assembly is shaped differently than what is shown in Figure 5, see shop drawing for clarification.* **See Figure 5**

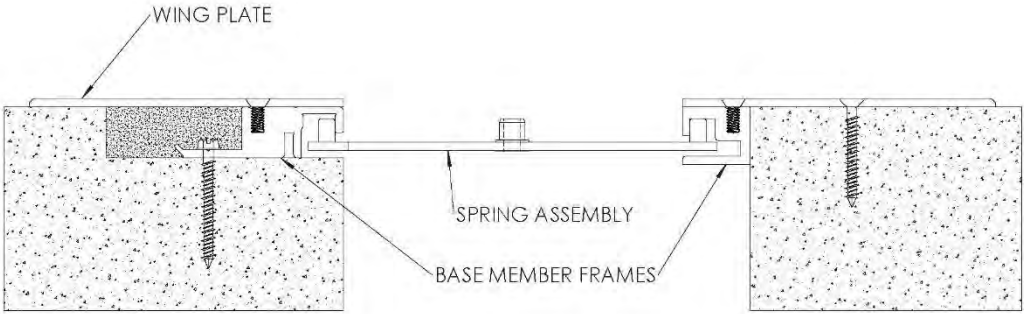

FIGURE 5



6. Position the cover plate centered over the base frame and with the center hole aligned with the spring assemblies. Attach the cover plate to the spring assemblies with the provided spring screws. **DO NOT OVERTIGHTEN. See Figure 6**

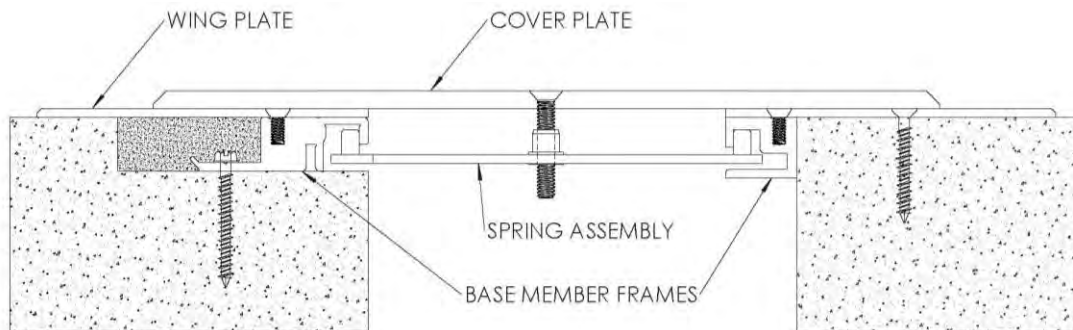

FIGURE 6

## ESFBw Floor to Wall Cover System



### GENERAL DESCRIPTION

The ESFBw Interior Cover System is designed to match the ESFB cover plate in floor to wall applications.

### Included with the expansion joint system:

- 3/16" x 1-3/4" Tapcon fastener

### Pre-Installation

1. Pour floors with blockouts as shown on shop drawings. The blockout should be a minimum of 1" wider than the exposed cover width by the specified depth.
2. Ensure that the blockout is smooth. High spots should be ground down and low spots filled in. Make sure the blockout is clean by sweeping and/or vacuuming.



## INSTALLATION

1. Remove the factory installed #10-24 screw that attaches the wing plate to the base member frame and retain for reinstallation later. **See Figure 1**

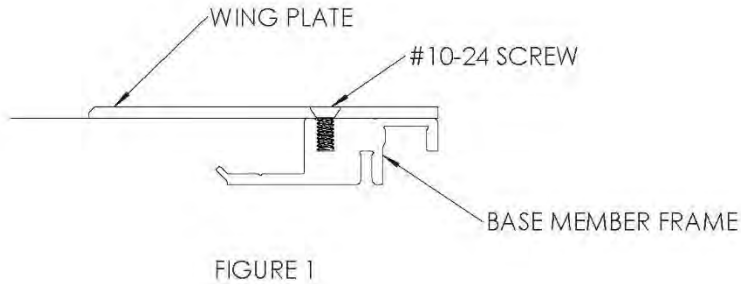

2. Position base member frame in blockout per shop drawings. Using the frame as a template, mark and drill 3/16" holes for Tapcon fasteners. Install base member frame to the blockout opening with fasteners, making sure not to over tighten. **See Figure 2**

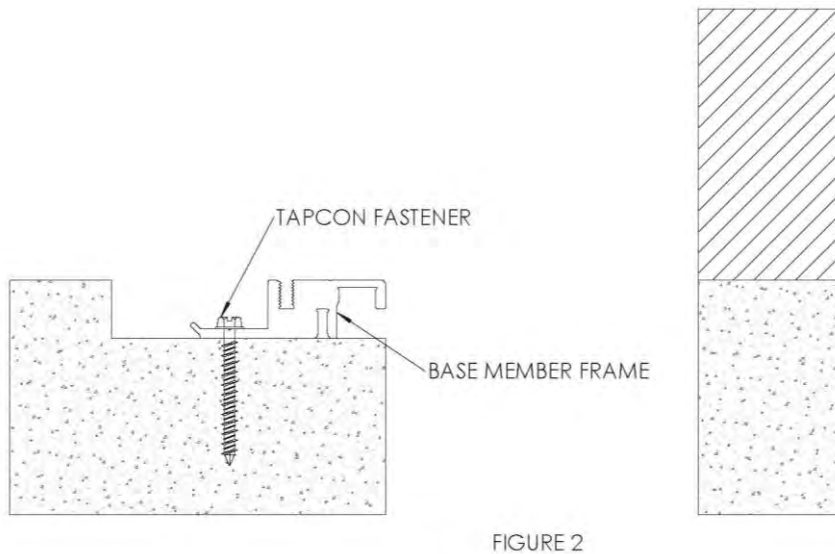

3. Protect the exposed surface of the expansion joint, then using an appropriate infill material, fill in the blockout level with the surrounding floor. **See Figure 3**

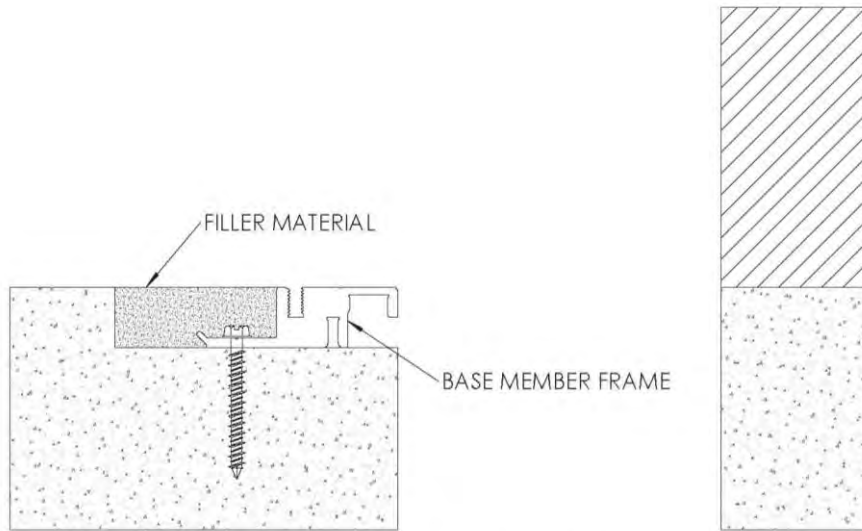

FIGURE 3

4. After infill material has cured, reinstall the wing plate to the base member frame with the #10-24 screw. **See Figure 4**

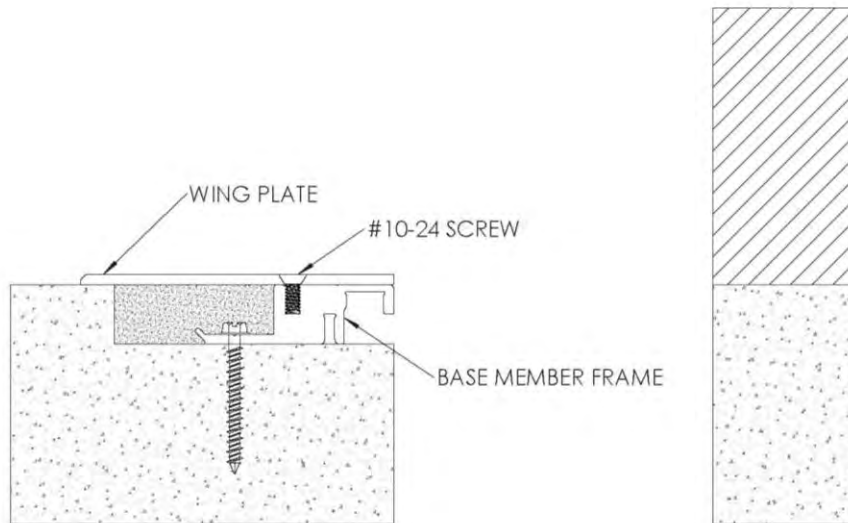

FIGURE 4

5. Position the cover plate against the wall as shown, making sure the bottom of its horizontal face is level with the top surface of the wing plate. Attach the plate to the wall using appropriate fasteners (by others) for the wall type, spaced 18" o.c. **See Figure 5**

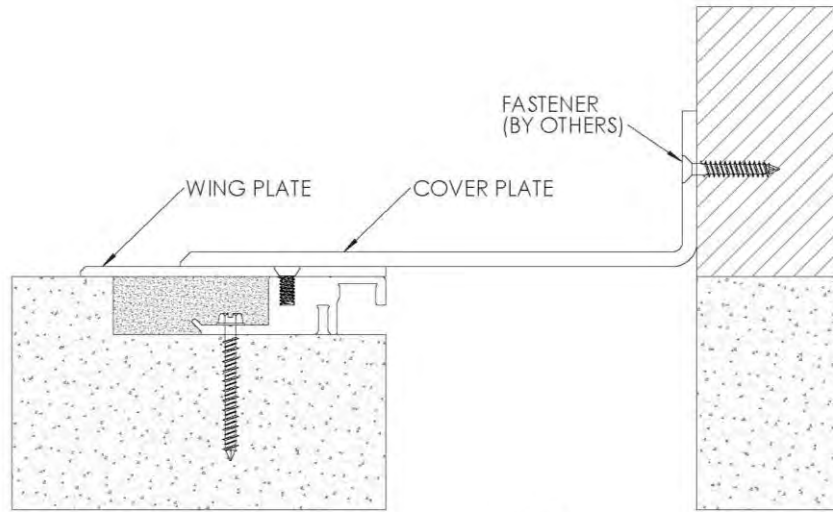

FIGURE 5



Erie Metal Specialties, Inc.  
13311 Main Road  
Akron, NY 14001  
Phone: 716-542-3991  
Fax: 716-542-3996  
Email: sales@eriemetal.com  
Website: www.eriemetal.com

## SPECIFICATION

### Section 07 95 13

#### Erie Metal Specialties, Interior Architectural Systems

Model(s) "ESFE", "ESFB"

#### Seismic Floor Expansion Control Systems

##### PART 1 - GENERAL

###### 1.01 Work Included

- A. The work shall consist of furnishing and installing expansion joints in accordance with the details shown on the plans and the requirements of the specifications. The joints are proprietary designs utilizing extruded elastomeric seals, aluminum base members and support plates.
- B. Related Work
  - Cast-in-place concrete
  - Miscellaneous and ornamental metals
  - Flashing and sheet metal

###### 1.02 Submittals

- A. Template Drawings - Submit typical seismic joint cross-section(s) indicating pertinent dimensioning, general construction, component connections, and anchorage methods.

###### 1.03 Product Delivery, Storage and Handling

- A. Deliver products in each manufacturer's original, intact, labeled containers and store under cover in a dry location until installed. Store off the ground, protect from weather and construction activities.

###### 1.04 Acceptable Manufacturer

- A. All joints shall be supplied by; Erie Metal Specialties, Inc. • 13311 Main Road • Akron • New York • 14001 • Phone (716) 542-3991 • Fax (716) 542-3996 • [sales@eriemetal.com](mailto:sales@eriemetal.com) • [www.eriemetal.com](http://www.eriemetal.com) .
- B. Alternate manufacturers and their products will be considered, provided they meet the design concept and are produced of materials that are equal to or superior to those specified.



Erie Metal Specialties, Inc.  
13311 Main Road  
Akron, NY 14001  
Phone: 716-542-3991  
Fax: 716-542-3996  
Email: sales@eriemetal.com  
Website: www.eriemetal.com

- C. Any proposed alternate systems must be submitted and receive approval 21 days prior to the bid. All post bid submittals will not be considered. This submission shall be in accordance with MATERIALS AND SUBSTITUTIONS.

- Any manufacturer wishing to submit for prior approval must provide the following:

- A working 6" sample of the proposed system with a letter describing how system is considered superior to the specified system.

- A project proposal drawing that illustrates the recommended alternate system installed in the floor construction that is specific to the project. Typical catalog cut sections will not be considered.

- A Verifiable list of prior installations showing prior and successful experience with the proposed Systems.

- Any substitution products not adhering to all specification requirements within, will not be considered.

## 1.05 Quality Assurance

- A. Warranty: The Professional Series expansion control system's performance shall be warranted for a period of 3 years when installed by the manufacturer's factory trained Certified Applicator. Installation shall be in strict accordance with manufacturer's technical specifications, details, installation instructions and general procedures in effect for normal intended usage and suitable applications under specified design movements and loading conditions.
- B. Manufacturer: Shall have a minimum ten (10) years experience specializing in the design and manufacture of Architectural Expansion Control Systems.
- C. Products: Expansion Control Systems must be installed with manufacturer's block out repair and infill material(s).
- D. Application: The specified expansion control systems shall be installed by a Certified Applicator, factory trained and certified in the proper installation of the specified expansion control system and fire barrier system.
- E. Maintenance: The manufacturer shall provide the owner-operator a preventive maintenance guideline for Expansion Control Systems.

## PART 2 - PRODUCT

### 2.01 General

- A. Provide floor joint cover expansion control system that can accommodate multi-directional seismic movement without stress to its components. System shall consist of metal profiles that utilize various metal finishes with a choice of aluminum base members designed to accommodate various project conditions and finish floor treatments. The cover plate shall be designed of width and thickness required to satisfy projects movement and loading requirements. Secure cover



Erie Metal Specialties, Inc.  
 13311 Main Road  
 Akron, NY 14001  
 Phone: 716-542-3991  
 Fax: 716-542-3996  
 Email: sales@eriemetal.com  
 Website: www.eriemetal.com

plate to base members by utilizing manufacturer’s pre-engineered seismic-centering bar. Anchor floor joint cover system to floor slab selecting one of the manufacturer’s appropriate anchoring systems.

Furnish EMS, Model(s) “ESFE” and “ESFB” floor joint cover meeting ADA Guidelines for pedestrian areas in interior and exterior joint locations as indicated on drawings. Select model based on project requirements.

2.02 Components and Materials

- A. Aluminum Extrusions - Material to conform to properties of ASTM B221, alloy 6061-T6 or 6063-T5.
- B. Aluminum Shapes - Material to conform to ASTM B209, alloy 6061-T6, or 5005-H34.
- C. Slide Plate - Provide minimum 3/16” thick plate with material to be aluminum conforming to ASTM B209, alloy 6061-T6. Where loading requirements do not dictate a structural alloy, utilize 5005-H34 for slide plate installed in a floor to wall condition. Slide plate to be secured to joint assembly utilizing a pre-engineered self-centering bar that freely rotates in all directions. Preformed metal devices that utilize tension or compression to maintain and secure slide plate will not be allowed.
- D. Seismic-Centering Bar - Shall exhibit circular sphered ends that lock and slide inside the corresponding aluminum extrusion cavity to allow freedom of movement and flexure in all directions including vertical displacement. Bar shall be molded or manufactured incorporating corrosion resistant nylon components with sphered ends and 1” wide standard cross member for standard applications. Provide 1 ½” wide cross member where heavy-duty application is required. Spacing shall be a maximum of 18” o.c.

During seismic activity design centering bar to permit vertical displacement of metal cover during accelerated inward and outward movement without evidence of fatigue and permanent deformation. Concurrently provide secure connection between plate and underlying system components to maintain proper positioning and contact to adjoining surfaces.

Bar shall exhibit the following physical properties to demonstrate ability to resist corrosion and fatigue.

**PHYSICAL PROPERTIES**

Molded End Profile:

Material:	Nylon
Color:	Black
Tensile Strength @ break:	ASTM D638 25,500 psi

Cross-Member:

Material:	Pre-tempered spring steel
-----------	---------------------------



Erie Metal Specialties, Inc.  
 13311 Main Road  
 Akron, NY 14001  
 Phone: 716-542-3991  
 Fax: 716-542-3996  
 Email: sales@eriemetal.com  
 Website: www.eriemetal.com

Damage Mitigation - Test Requirements:

Seismic-centering bar must exhibit ability to disengage (controlled release) from expansion joint edge member(s) when seismic movement exceeds the specified maximum allowable opening. Submit independent test report demonstrating required design of seismic-centering bar.

Requirements

- a) Equipment: Instron Machine
- b) Orientation: Specimen subjected to tensile load with crossmember parallel to direction of load.
- c) Specimens: Test 4(min) – select at random
- d) Disengagement range (lbs): 800 (min.) – 1250 (max.)

- E. Moisture Barrier - Shall be a fabric reinforced tear resistant clean vinyl sheet material. Minimum Thickness shall be .026”.
- F. Anchorage - Provide minimum 1/4” diameter anchor at maximum 24” o.c. spacing. Type of anchor and method of attachment to be determined by project conditions.
- G. Block out Repair - Utilize manufacturer’s single component rapid strength repair mortar meeting the following data requirements.

Compressive strength, psi (ASTM C 109)

2 hours	1,500
24 hours	4,500
7 days	8,000
28 days	9,000

- H. Block out Infill - Utilize manufacturer’s non-catalyzed, non-shrink grout containing mineral aggregate meeting the following data requirements.

Compressive strength at plastic consistency, psi

3 days	6,000
7 days	7,000
28 days	8,500

- I. Accessories - Provide necessary and related parts, and fasteners required for complete installation.





Erie Metal Specialties, Inc.  
13311 Main Road  
Akron, NY 14001  
Phone: 716-542-3991  
Fax: 716-542-3996  
Email: sales@eriemetal.com  
Website: www.eriemetal.com

- J. Fire Barrier Assembly - Designed for indicated or required dynamic structural movement without material degradation or fatigue. Tested in maximum joint width conditions with a field splice as a component of the expansion joint cover in accordance with ASTM E-119 at full rated period by a nationally recognized testing and inspecting organization. Supply Erie Metal's Fire Barrier as governed by joint opening and fire rating.

#### 2.03 Fabrication

- A. Extrusions and generic profiles to be shipped in standard 10 ft. lengths and shall be cut to length on jobsite where required. Profiles shall be miter cut in the field to conform to directional changes unless otherwise contracted with expansion joint manufacturer.
- B. Fire Barriers - Ship manufacturer's standard assembly including fire caulks, sealants (if applicable) and hardware for the required hourly rating. Assemblies shall be miter cut in the field to accommodate changes in direction.

#### 2.04 Finishes (Standard)

- A. The cover plate's exposed surface shall receive a 60-grit brushed finish. All other aluminum extrusions and shapes shall be supplied in standard mill finish.
- B. Surfaces of aluminum profiles that will be in direct contact with concrete where moisture is present shall receive one coat of manufacturer's recommended coating.

### **PART 3 - EXECUTION**

#### 3.01 Installation

- A. Install all Expansion Control Systems utilizing manufacturer's block out repair and infill material(s).
- B. Protect all expansion joint component parts from damage during installation, placement of concrete and thereafter until completion of structure.
- C. Expansion joint systems shall be installed in strict accordance with the manufacturer's typical details and instructions along with the advice of their qualified representative.
- D. Expansion joint systems shall be set to the proper width for the ambient temperature at the time of installation. This information is indicated in the contract plans.

#### 3.02 Clean and Protect

- A. Protect system and its components during construction. After work is complete in adjacent areas clean exposed surfaces with a suitable cleaner that will not harm or attack the finish.

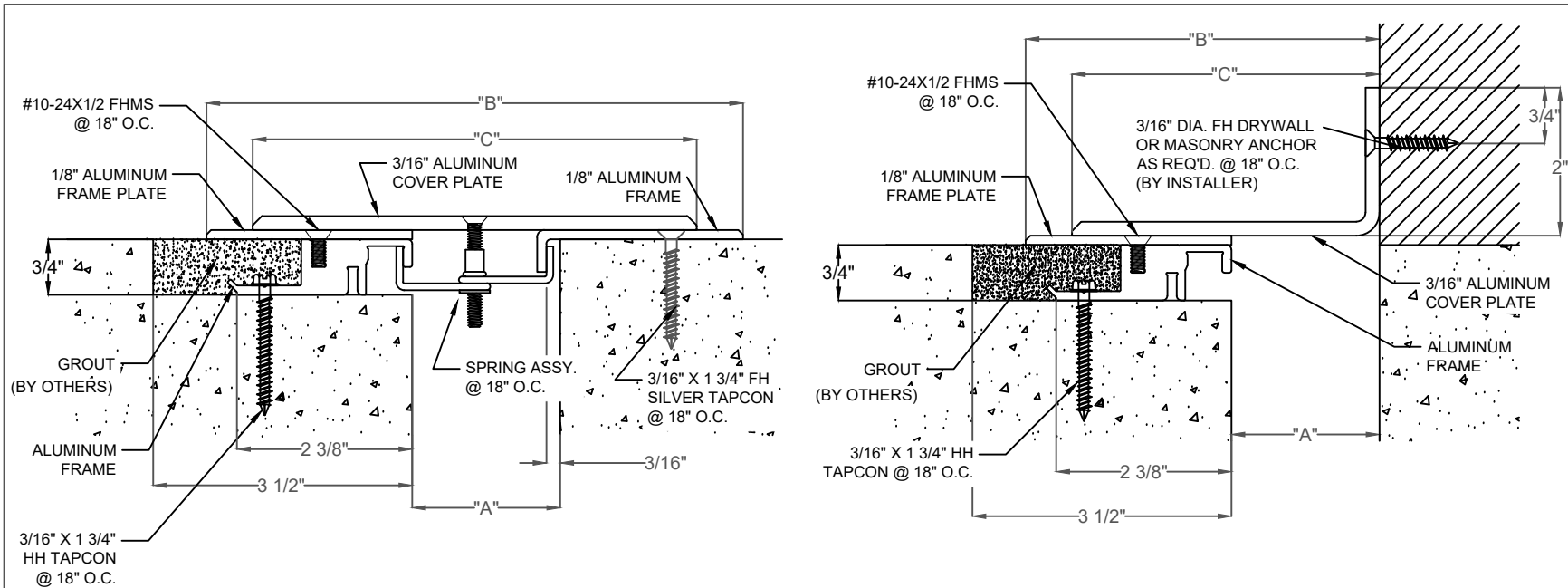

**FLOOR TO FLOOR/WALL - BLOCKOUT TO SURFACE MOUNT**

EXPOSED FINISH: MILL

MOVEMENT: +/- 50% JOINT WIDTH (floor-floor)

MOVEMENT: +/- 25% JOINT WIDTH (floor-wall)

STOCK LENGTHS: 10'-0"

PRODUCT	Application	Joint Size "A" @ Mean T°F	Exposed Site line "B" IN(MM)	Top Plate Width "C" IN(MM)	Total Movement IN (MM)
ESFB-200	Floor-Floor	2.00" (51)	7.25" (184)	6.00" (152)	2.00" (51)
ESFB-200W	Floor-Wall	2.00" (51)	4.75" (121)	4.1875" (106)	1.00" (25)

NO.	Description	Date	By
<small>The information contained herein is the proprietary property of ERIE METAL SPECIALTIES, INC. No portion of it may be reproduced by any means or used in any form except for the purpose for which it was intended. All rights of design and invention are hereby reserved.</small>			



13311 Main Road \* Akron \* New York \* 14001  
 Phone: (716) 542-3991 \* Fax: (716) 542-3996 \* E-mail: sales@eriemetal.com

PROJECT:

---

TITLE: ESFB-200/200W

Detailed by:	Date:
BAF	10/21/17
Checked by:	Date:
SLP	10/21/17
Scale:	EMS Job #:
NTS	
Sheet No.:	Drawing No.:
1 of 1	ESFB-1

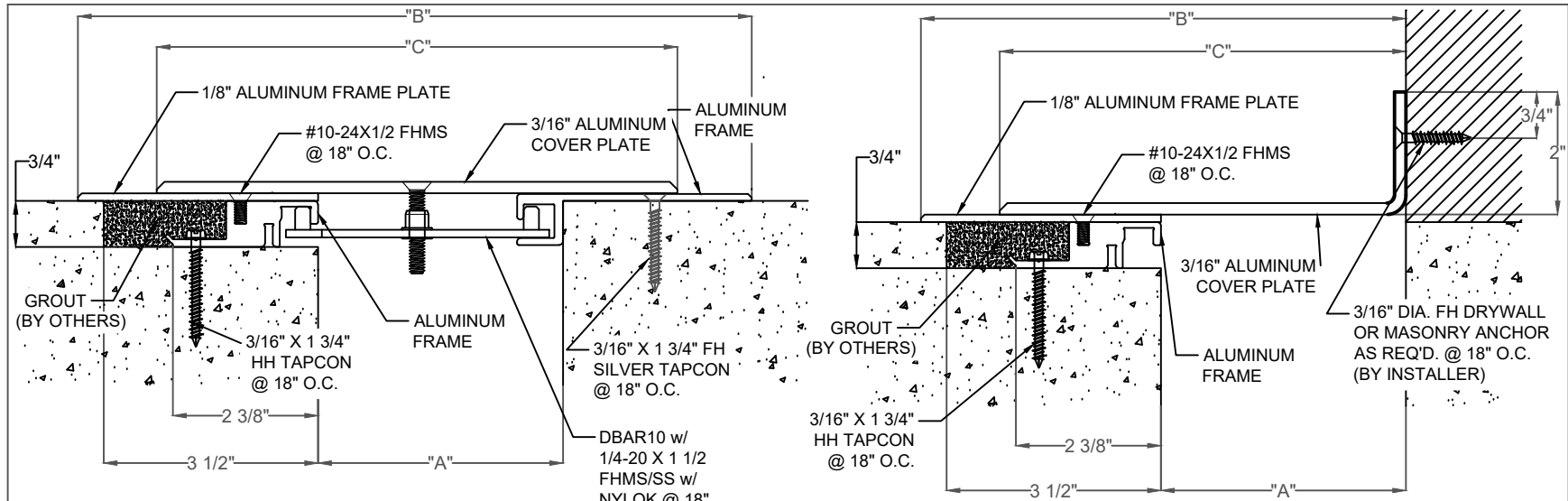

PRODUCT	Application	Joint Size "A" @ Mean T°F	Exposed Site line "B" IN(MM)	Top Plate Width "C" IN(MM)	Total Movement IN (MM)
ESFB-400	Floor-Floor	4.00" (102)	11.00" (279)	8.50" (216)	4.00" (102)
ESFB-600	Floor-Floor	6.00" (152)	14.25" (362)	11.00" (279)	6.00" (152)
ESFB-800	Floor-Floor	8.00" (203)	17.75" (451)	13.50" (343)	8.00" (203)
ESFB-1000	Floor-Floor	10.00" (254)	21.25" (539)	16.00" (406)	10.00" (254)
ESFB-1200	Floor-Floor	12.00" (305)	25.25" (641)	19.00" (482)	12.00" (305)
ESFB-400W	Floor-Wall	4.00" (102)	7.94" (201)	6.625" (168)	2.00" (51)
ESFB-600W	Floor-Wall	6.00" (152)	10.62" (270)	9.00" (229)	3.00" (76)
ESFB-800W	Floor-Wall	8.00" (203)	13.37" (340)	11.25" (286)	4.00" (102)
ESFB-1000W	Floor-Wall	10.00" (254)	16.12" (410)	13.50" (343)	5.00" (127)
ESFB-1200W	Floor-Wall	12.00" (305)	19.12" (486)	16.00" (406)	6.00" (152)

***FLOOR TO FLOOR/WALL - BLOCKOUT TO SURFACE MOUNT***

EXPOSED FINISH: MILL

MOVEMENT: +/- 50% JOINT WIDTH (floor-floor)

MOVEMENT: +/- 25% JOINT WIDTH (floor-wall)

STOCK LENGTHS: 10'-0"

NO.	Description	Date	By

The information contained herein is the proprietary property of ERIE METAL SPECIALTIES, INC. No portion of it may be reproduced by any means or used in any form except for the purpose for which it was intended. All rights of design and invention are hereby reserved.



13311 Main Road \* Akron \* New York \* 14001  
 Phone: (716) 542-3991 \* Fax: (716) 542-3996 \* E-mail: sales@eriemetal.com

PROJECT:

TITLE: ESFB-400/400W, 600/600W, 800/800W, 1000/1000W, 1200/1200W

Detailed by:	Date:
BAF	10/21/17
Checked by:	Date:
SLP	10/21/17
Scale:	EMS Job #:
NTS	
Sheet No.:	Drawing No.:
1 of 1	ESFB-1