

EFLP-Series Installation Instructions

SEISMIC PAN FLOORING SYSTEM – BLOCKOUT APPLICATION

MODEL(S): EFLP/EFLPw

FLOOR TO FLOOR COVER SYSTEM – 2” SIZE ONLY

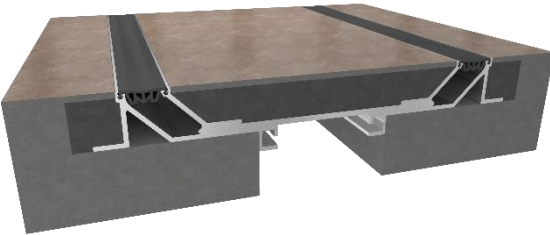

GENERAL DESCRIPTION

EMS’ Seismic Pan Flooring System is commonly used for stone, terrazzo tile and concrete slabs as well as most traditional flooring materials in courtyards and walkways. It’s capable of accommodating lateral shear and multidirectional movement including

GENERAL SAFETY PRECAUTIONS Improper selection, installation, or use can cause personal injury or property damage. It is solely the responsibility of the user, through their own analysis, to select products suitable to the specific application requirements, ensure proper maintenance and use as intended. Follow local, state, and federal regulations for proper installation and operation requirements.

vertical displacement.

Introduction + Safety

Please read the complete instructions carefully before beginning any work. To ensure proper installation and performance of the product, the following actions must be completed by the installing contractor. Failure to do so will affect the product warranty.

Transportation + Storage

- Inspect all shipments and materials for missing or damaged components and hardware.
- Material must be stored in a clean, dry location.

Preparation

- Locate the packing slip(s) and/or shop drawings.
- Verify that all products listed on the packing slip are included in the package.
- Check the products for damage. If products are damaged, report a freight claim immediately and leave the products in their packaging. If you sign for products without reporting damage, you waive your right to a freight claim and will be responsible for replacement costs.
- Read the instructions thoroughly before beginning installation.



Tool List

- Tape measure
- Phillips screwdriver
- Vinyl tile roller
- Drivers for anchors
- Levels
- Denatured alcohol & clean rags
- Duct tape
- Rubber mallet
- Wooden block
- Trowel
- Chop saw to cut product to length
- Drill with 3/16” masonry bit
- Broom & dustpan or vacuum

Included with the expansion joint system

- Ø1/4” x 2-1/4” HH Tapcon (#32088)
- Ø1/4” x 2-1/4” FH Tapcon (#32089)
- Ø1/4” x 1.0” Self-Tapping Screw (#30032) for butt-splice connectors

Preinstallation

1. Pour slabs with blockouts as shown on shop drawings. Note: Blockout width changes with System size.
2. Ensure the area where the expansion joint system is being installed (including the blockout area) is smooth and level. High spots should be ground down and low spots filled in. Make sure the substrate is clean by sweeping and/or vacuuming the substrate.



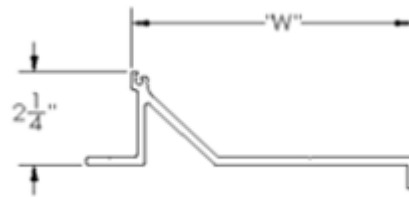

Aluminum Pan		
Model #	Part #	"W" Dimension
EFLP-200	32064	10.25"

Aluminum Edge Frame		
Model #	Part #	"W" Dimension
EFLP-200	32044	6.3125"

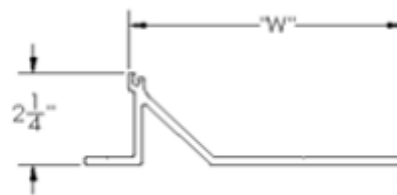
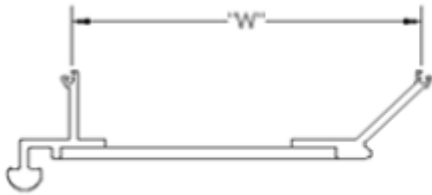

Aluminum Pan		
Model #	Part #	"W" Dimension
EFLP-200W	32076	4.44"

Aluminum Edge Frame		
Model #	Part #	"W" Dimension
EFLP-200W/400W	32044	6.3125"

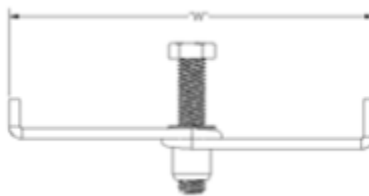

Seismic Centering Bar		
Model #	Part #	"W" Dimension
EFLP-200	WBAR5-KIT-FLP	5.1205"

INSTALLATION (EFLP-200 ONLY)

After determining that the area is smooth and level, the installer shall inspect opposing concrete slabs, corners and blockouts for acceptability. For repair (if required) refer to preinstallation Step #2. Also, measure joint opening for proper size as called for on shop drawings and for specific blockout information. **See Figure #1**

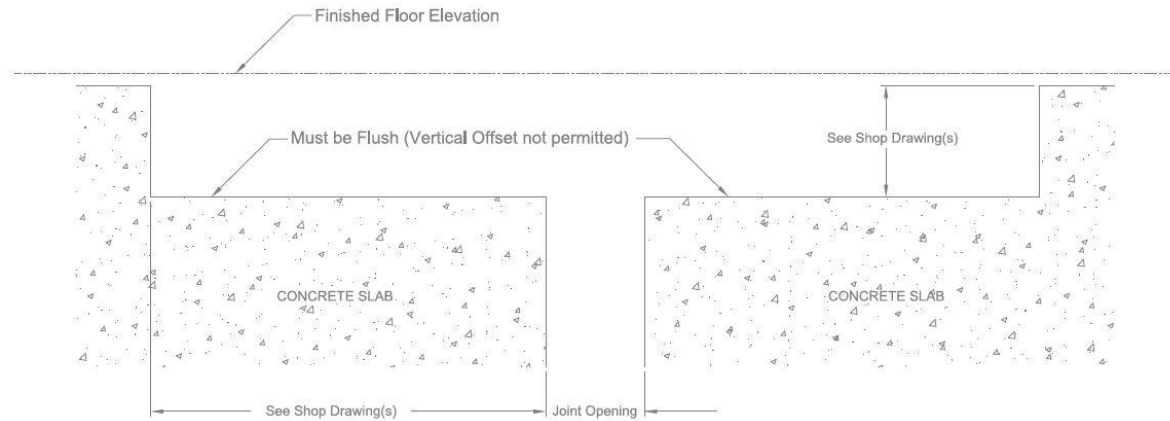

Figure #1

1. On each of the aluminum base members find the “V score marks” to pre-locate the holes required to drill. After predrilling the $\text{Ø}3/16$ ” holes in the aluminum bases per the shop drawings, position them in the blockouts as shown below. Using the frame as a template, mark and drill $\text{Ø}3/16$ holes in the blockout for the $\text{Ø}1/4$ ” Tapcon anchors using the “V score marks to locate”. Set the aluminum bases into position and attach with supplied $\text{Ø}1/4$ ” Tapcons through the previously drilled holes as shown on the shop drawings. (Note: stagger seams on opposite sides of the joint opening – see Step #6 before proceeding.) **See Figure #2**

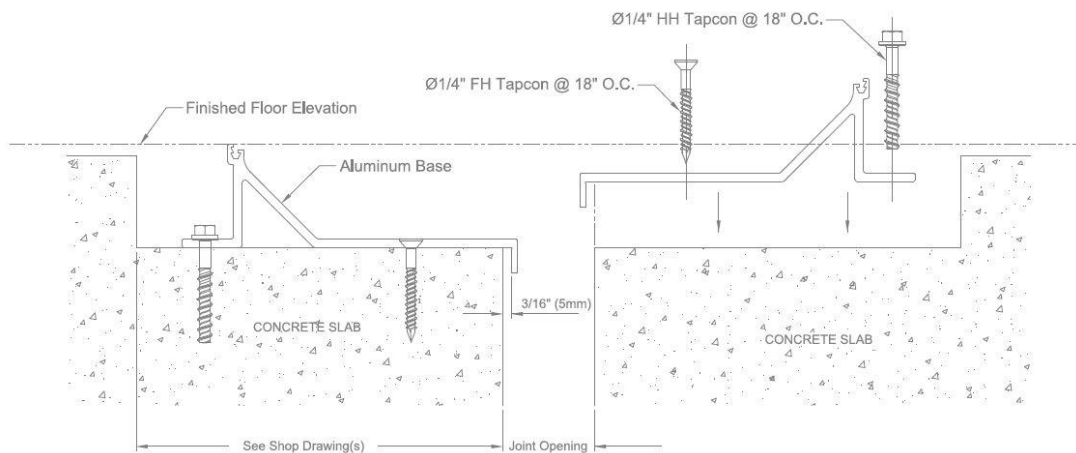
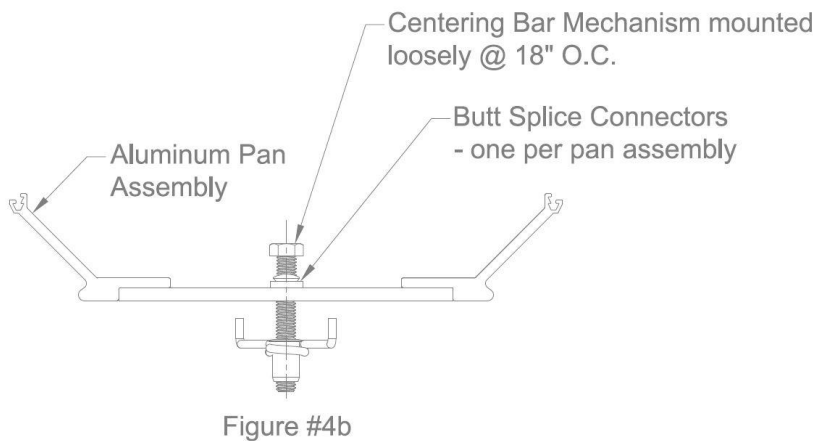
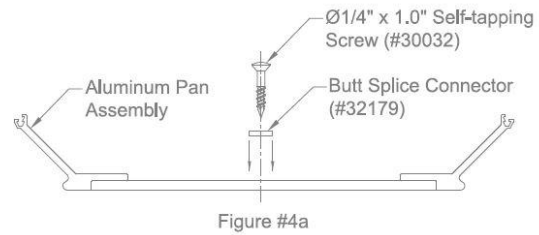
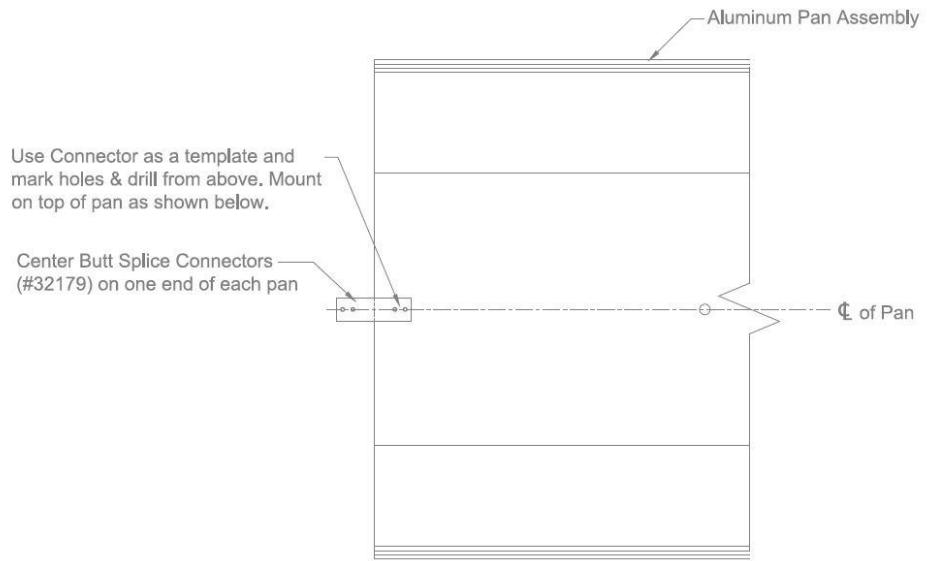

Figure #2

2. After aluminum bases are installed, start adding centering bar mechanisms and butt splice connections to one end of each aluminum pan. This can be done outside of the blockout / joint opening. Using the butt splice connector (#32179) as a template, locate as shown in Figure #4. From the top, mark and drill the two $\text{Ø}3/16$ " holes at one end of each pan. When assembling in block out, use $\text{Ø}1/4$ " screws provided (#30032) as shown below. Connectors should be placed in the inside bottom of the pan at one end – one per pan assembly. See **Figure #4a & 4b**.



- Center the aluminum pan assembly over the joint opening as shown below. Once pan(s) are in place, tighten and snug up the centering bar mechanisms. Mechanisms must tuck under the “lip” of the aluminum bases but must spin freely when joint opens and closes. **See Figure #5.**

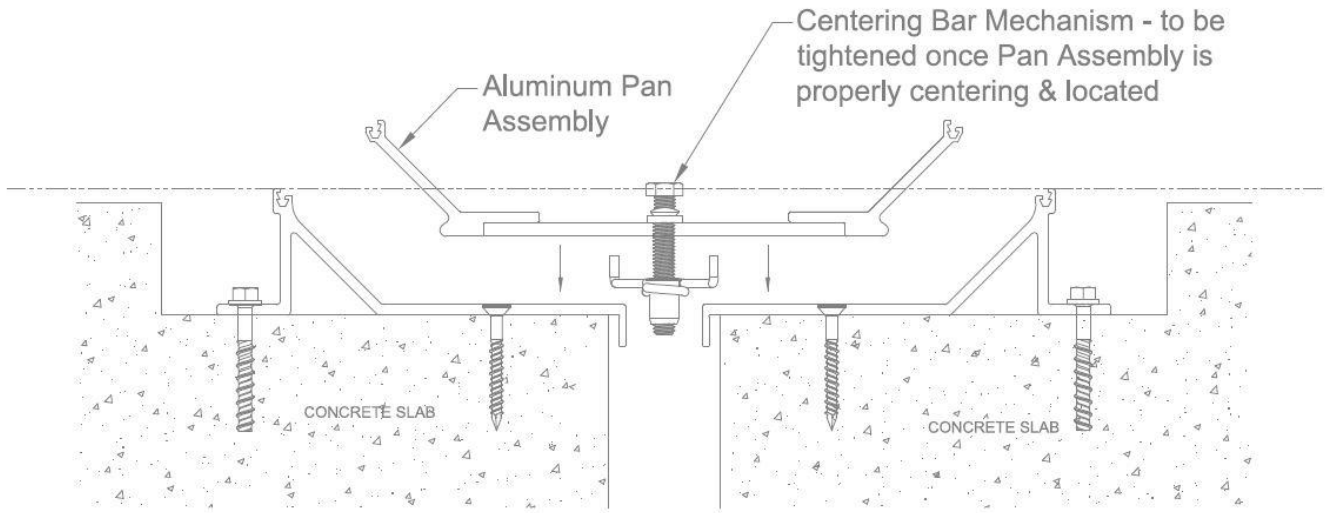

Figure #5

- Make sure to not overtighten – centering bars mechanisms must move freely. Cover bolt heads with plastic caps (#32094) before adding infill (see Step #8). **See Figure #6.**

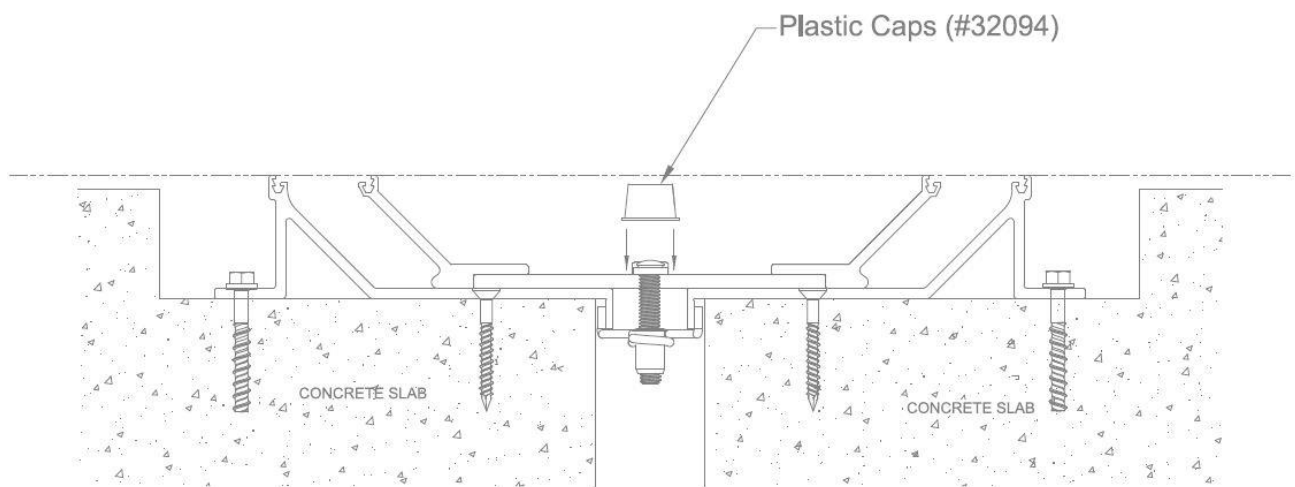

Figure #6

5. Ensure aluminum pan sections butt tightly together and that the outside edges align from section to section. Remember to stagger the seams as shown in Figure #7. Once all the aluminum pans are butted tightly together and all butt splice connectors are installed, inspect all $\text{\O}3/8$ " hex head bolts to confirm the centering bars spin freely. **See Figure #7.**

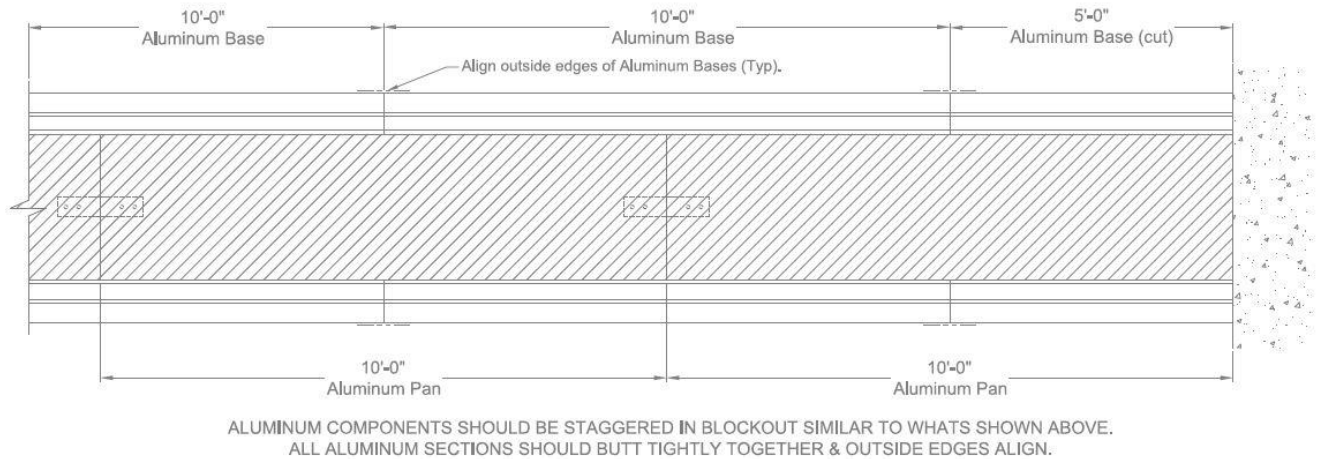

Figure #7

6. Use duct tape or similar heavy tape continuously on each side of the EJ System to protect joint opening through the next final steps. **See Figure #8.**

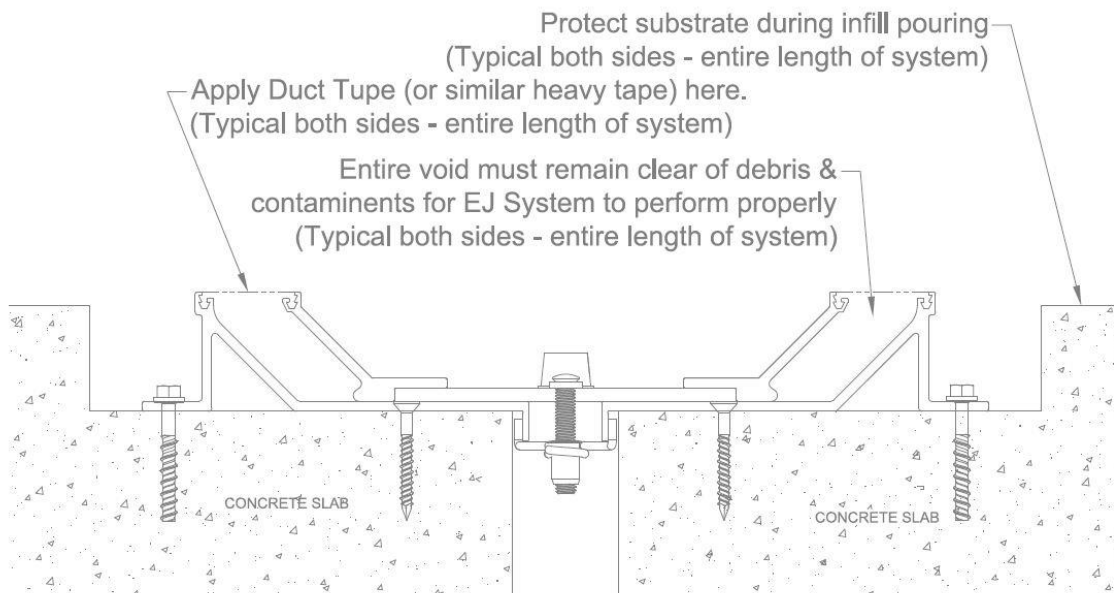

Figure #8

7. Before mixing the infill, material care should be taken to remove all dust and debris from the blockout areas and inside the aluminum pan. All surfaces must be clean and dry prior to installing infill. Pour infill material into blockout voids and pan cavity. **Warning! Leave required recess for floor finish, finish material thickness, and proper placement. See Figure #9.*

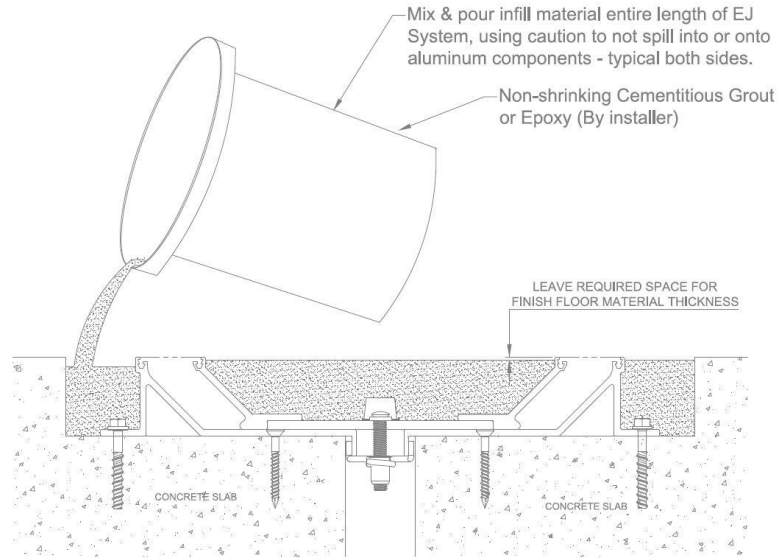

Figure #9

8. Install finished floor material. Be sure to follow manufacturer instructions. Joint opening should remain protected throughout this process. **See Figure #10.**

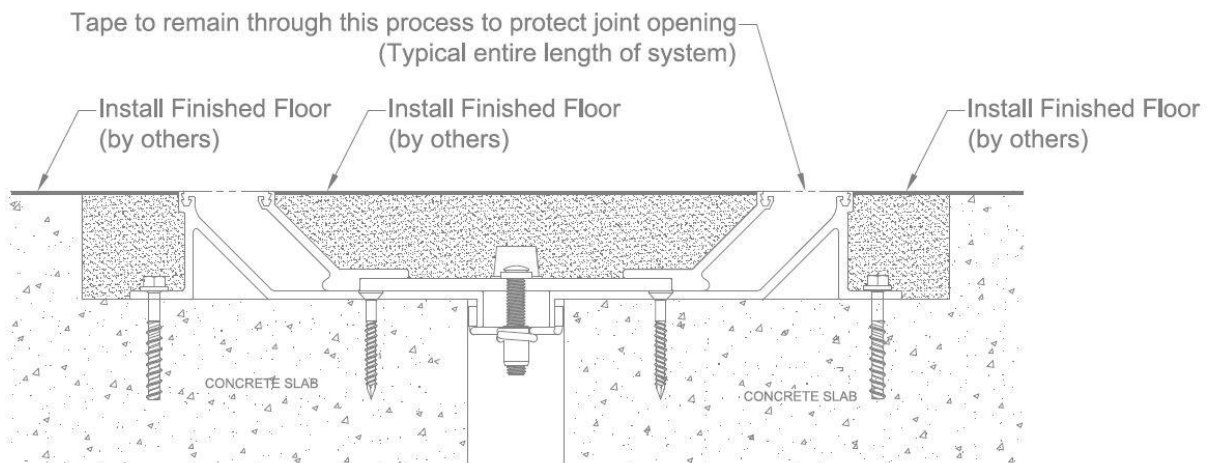

Figure #10

9. Remove heavy tape from joint opening. Install elastomeric seals. Use a vinyl tile roller or similar, to ensure seal tabs completely lock into cavities in aluminum components. Use care not to mark or tear seal. Final seal seams should be offset from all other aluminum seams. Clean off seals using denatured alcohol and a clean rag when complete to remove any construction dust or debris. **See Figure #11.**

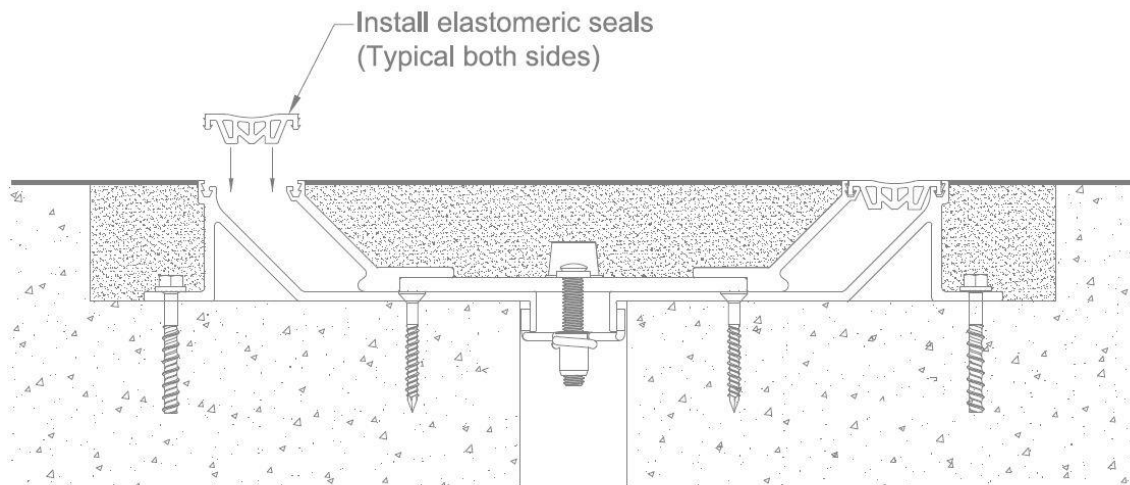
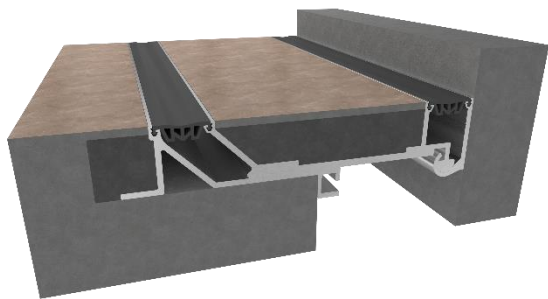

Figure #11

FLOOR TO WALL COVER SYSTEM- 2” SIZE ONLY



GENERAL DESCRIPTION

EMS' Seismic Flooring Pan System is designed to match the EFLP system in corner applications.

Preinstallation

1. Pour slabs with blockouts as shown on shop drawings.
2. Ensure the area where the expansion joint system is being installed (including the blockout area) is smooth and level. High spots should be ground down and low spots filled in. Make sure the substrate is clean by sweeping and/or vacuuming substrate.

INSTALLATION

3. After determining that the area is smooth and level, the installer shall inspect opposing concrete slabs, corners and blockouts for acceptability. For repair (if required) refer to preinstallation Step #2, also, measure joint opening for proper size as called for on shop drawings and for specific blockout information. **See Figure #12.**

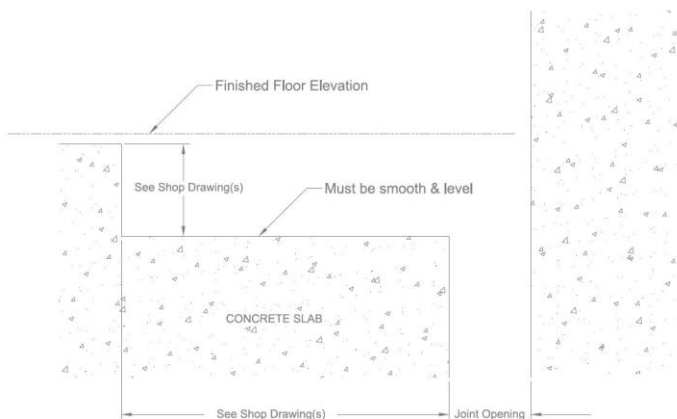

Figure #12

10. On each of the aluminum base members find the “V score marks” to pre-locate the holes required to drill. After predrilling the $\text{Ø}3/16$ ” holes in the aluminum bases per the shop drawings, position them in the blockout as shown below. Using the frame as a template, mark and drill $\text{Ø}3/16$ holes in the blockout for the $\text{Ø}1/4$ ” Tapcon anchors using the “V score marks” to locate. Set the aluminum bases into position and attach with supplied $\text{Ø}1/4$ ” Tapcons through the previously drilled holes as shown on the shop drawings. (Note: stagger seams the entire length of the joint opening – See Step #15 before proceeding.) **See Figure #13.**

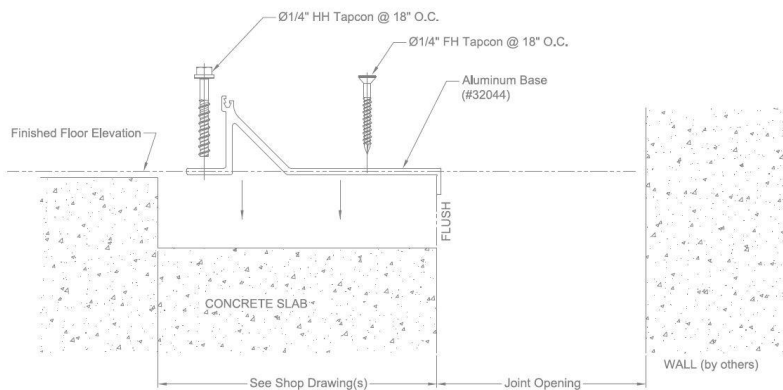

Figure #13

11. In preparation for fastening wall mount extrusion (#32051) predrill $\text{\O}3/16$ " holes as shown on the shop drawings – use the “V score mark” to properly locate the holes. Hold extrusion against wall and make sure that it is level with the adjacent aluminum edge frame assembly. Snap a chalk line to insure level installation. Use 5-foot piece wall mount at start of each join run. Fasten wall mounted aluminum base with $\text{\O}1/4$ " FH Tapcons utilizing the field predrilled holes as a template. **See Figure #14.**

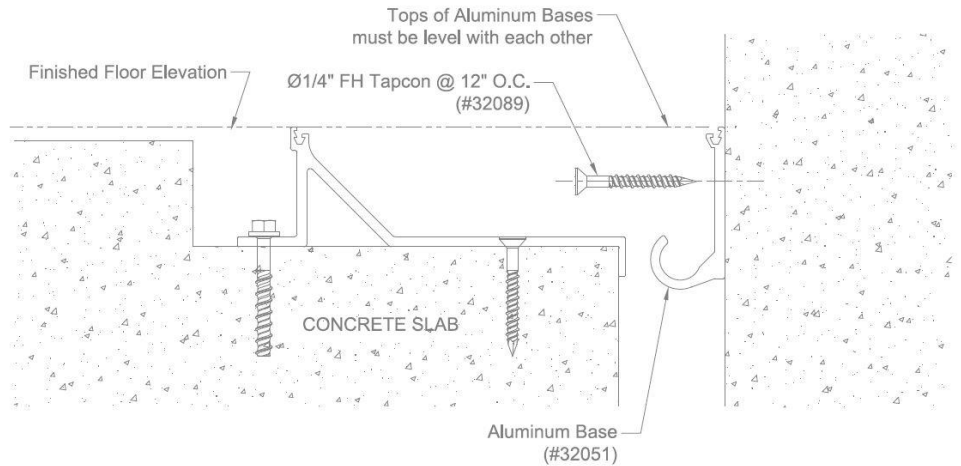

Figure #14

assembly. Snap a chalk line to insure level installation. Use 5-foot piece wall mount at start of each join run. Fasten wall mounted aluminum base with $\text{\O}1/4$ " FH Tapcons utilizing the field predrilled holes as a template. **See Figure #14.**

12. After aluminum bases are installed, start adding butt splice connections to one end of each aluminum pan. Using the butt splice connector as a template, locate as shown in Figure #16. From the top, mark and drill the two $\text{\O}3/16$ " holes at one end of each pan.

When assembling in blockout, use $\text{\O}1/4$ " screws (#30032) as shown below. Connectors should be placed in the inside bottom of the pan at one end – one per pan assembly. **See Figure #15.**

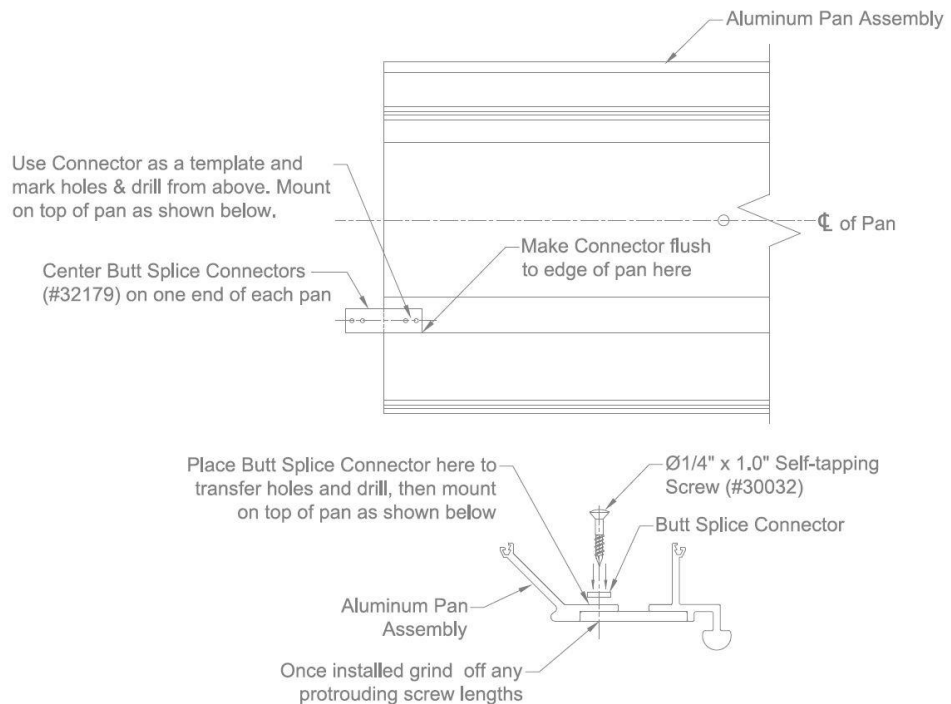

Figure #15

13. Gently set aluminum pans into place as shown above. **See Figure #16.**

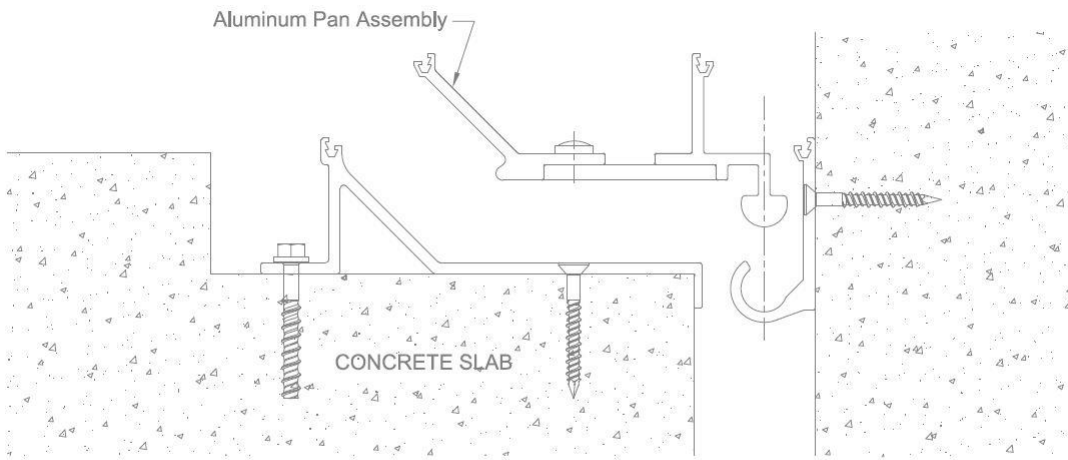

Figure #16

14. Repeat Steps #11 through 14 to align all sections of aluminum pans and aluminum bases. Ensure aluminum pan sections butt tightly together and that the outside edges align from section to section. Confirm all the aluminum pans are butted tightly together, and all butt splice connectors are installed properly. **See Figure #17.**

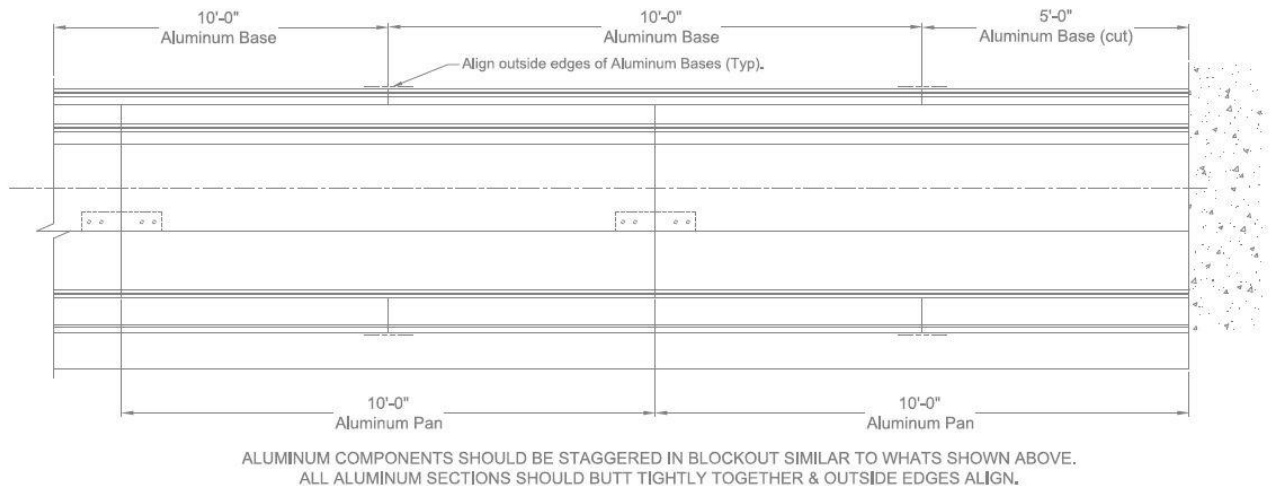

Figure #17

15. Use duct tape or similar heavy tape continuously on each side of the EJ System to protect joint opening through the next final steps. **See Figure #18.**

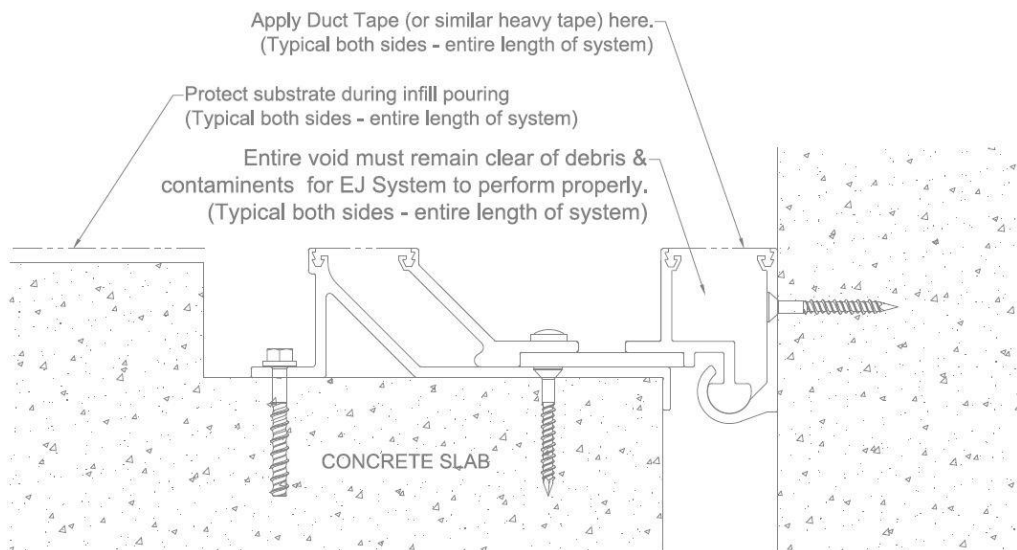

Figure #18

16. Before mixing the infill, material care should be taken to remove all dust and debris from the blockout areas and inside the aluminum pan. All surfaces must be clean and dry prior to installing infill. Pour infill material into blockout voids and pan cavity. *Warning! Leave required recess for floor finish, finish material thickness, and proper placement. **See Figure #19.**

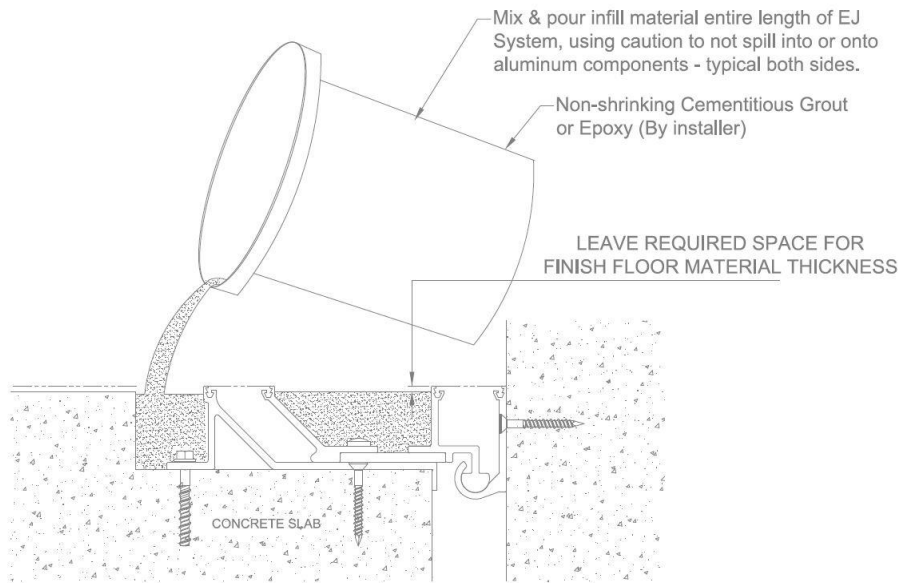

Figure #19

17. Install finished floor material. Be sure to follow the manufacturer instructions. Joint opening should remain protected throughout this process. **See Figure #20.**

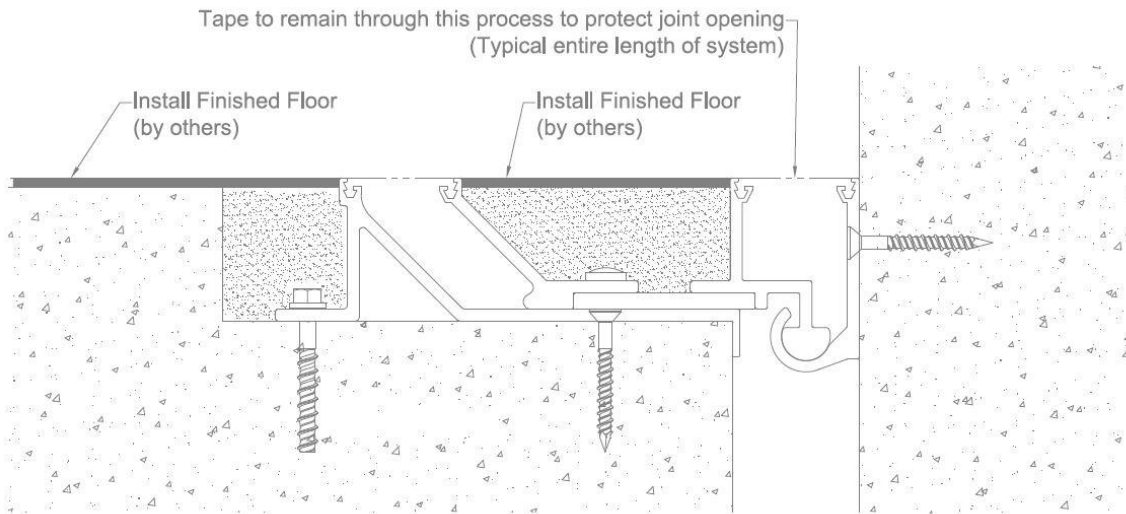

Figure #20

18. Remove heavy tape from joint opening. Install elastomeric seals. Use a vinyl tile roller or similar to ensure seal tabs completely lock into cavities in aluminum components. Use care not to mark or tear seal. Final seal seams should be offset from all other aluminum seams. Clean off seals using denatured alcohol and a clean rag when complete to remove any construction dust or debris. **See Figure #21.**

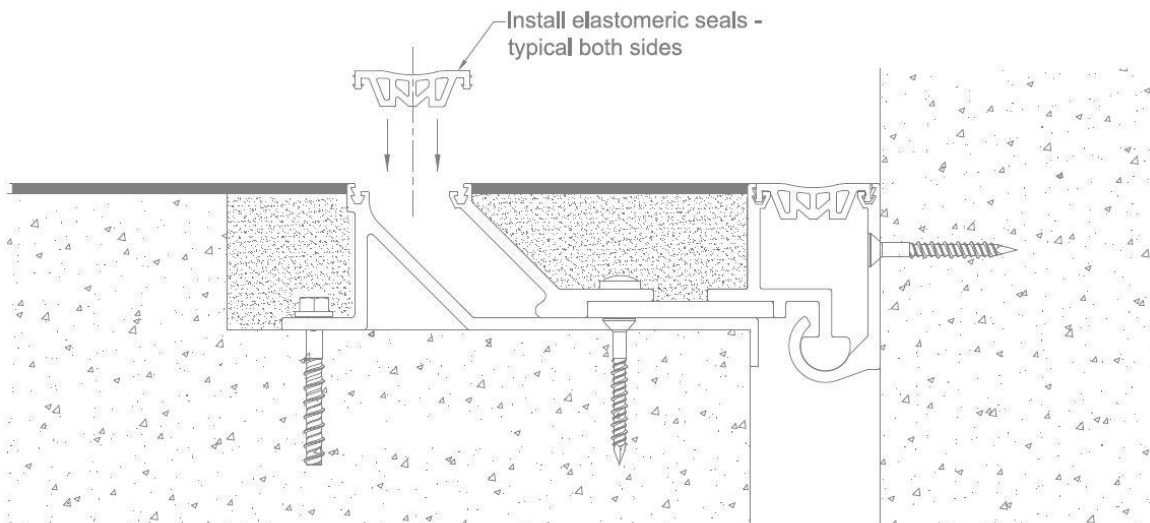

Figure #21